

# Screw drives Screw Jacks

09/2015

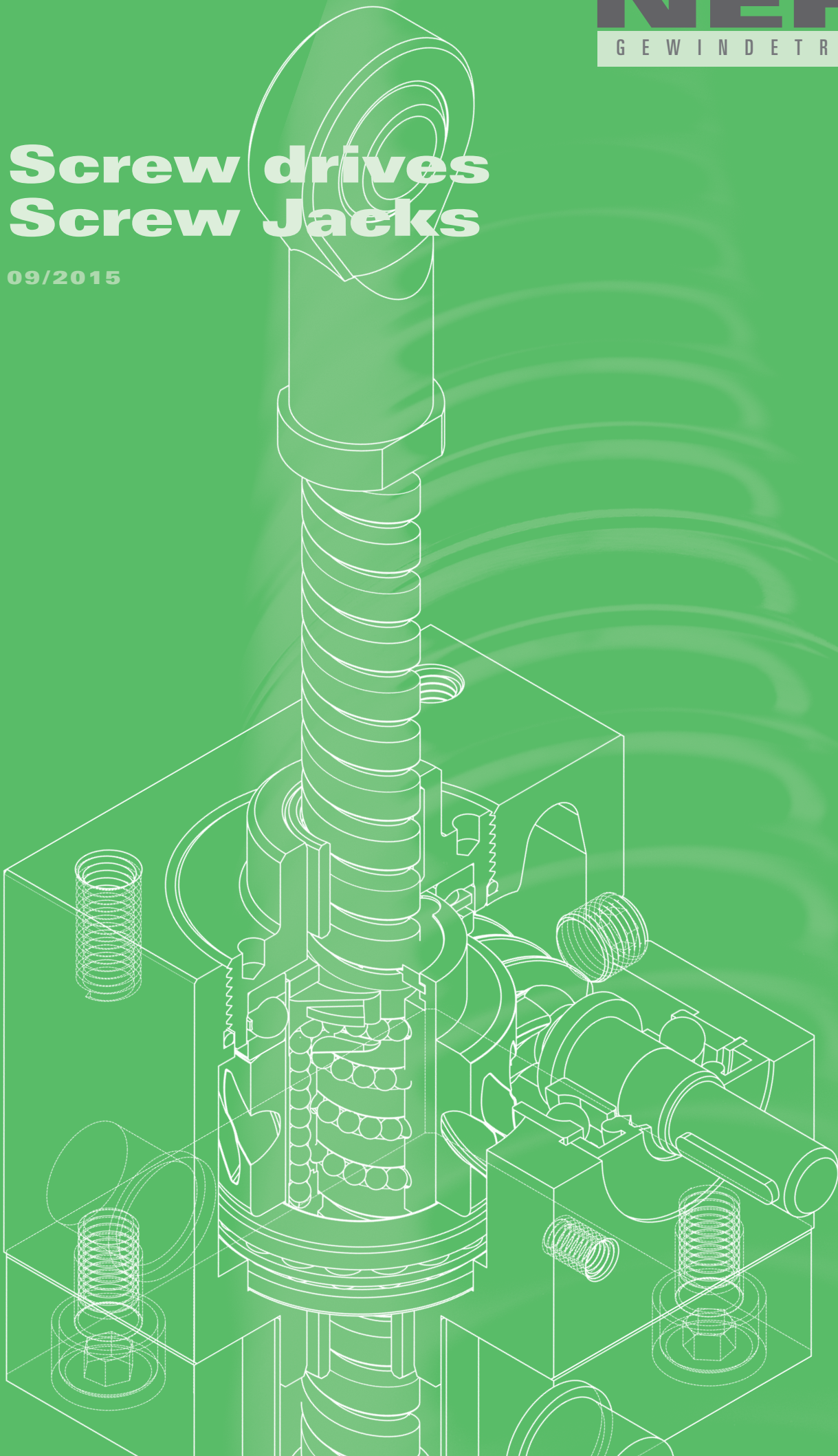

# Neff moves!

The name NEFF traditionally stands for high-quality screw drives. For over 100 years threads have been cut, spun, rolled or grounded. Today NEFF Gewindetriebe GmbH is a highly qualified development and manufacturing company. Our screw drives and lifting systems move machines and plants in the most diverse industries all over the world.

It has always been noticeable with NEFF that everything revolves around the customer. Not only do we supply first-class products; we as the NEFF team aim to offer customer-oriented, sustainable solutions. We want to pass on our extensive experience and communicate openly.

Entirely in keeping with this style, this revised and extended catalogue not only lists our stock standards, but is also intended to communicate basic technical principles in order to support the

user with the various drive tasks.

Regardless of whether you are a long-standing NEFF customer or whether you are just discovering us as a new customer – we look forward to cooperating with you.

On behalf of the entire NEFF team,  
Your



Hartmut Wandel  
Chief Executive Officer



## Here you can find us:

### NEFF Gewindetriebe GmbH Location Heilbronn

Ochenbrunnenstraße 10  
D-74078 Heilbronn  
Phone 07131 27177-60  
Fax 07131 27177-66

### NEFF Gewindetriebe GmbH

Karl-Benz-Straße 24  
D-71093 Weil im Schönbuch  
Phone 07157 53890-0  
Fax 07157 53890-25



# Contents

<b>Overview</b>	4 - 5
<b>Ball screw drive KGT</b>	
General technical data	6 - 7
Ball screws KGS	8
Ordering code for ball screws	9
Ball nut KGM/KGF	10 - 14
Ordering code for ball screw drive	15
Calculation Ball screw drive	16 - 20
<b>Trapezoidal screw drive TGT</b>	
General technical data	21 - 22
Trapezoidal screw	23 - 24
Calculation Trapezoidal-threaded spindle	25
Trapezoidal-threaded nut TGM	26 - 30
Ordering code Trapezoidal screw drive	31
Calculation Trapezoidal screw drive	32 - 37
<b>Accessories KGT and TGT</b>	
Screw end machining	38 - 41
Fixed bearing units	42 - 43
Grooved nut	44
Adaptor bracket	45
Universal joint adapter	46
Bellow	47 - 48
Spiral spring cover	49 - 51
Lubricants	52 - 53
Lubricant dispenser	53
<b>Installation and maintenance</b>	54
<b>Screw Jacks</b>	
General technical data	55 - 56
Dimensions and Verions M/J	57 - 61
Performance tables M/J	62 - 64
Ordering code Worm gear screw jacks M/J	65
High-speed screw jacks G1-G3	66 - 68
Performance tables G1-G3	69 - 72
Ordering code High-speed screw jacks	73
Examples of arrangement and direction of rotation	74 - 75
Calculation screw jacks	76 - 82
<b>Accessories Screw Jacks</b>	
Mounting feet	83
Universal joint adapter	84
Universal joint bearing	85
Top plate BP	86
Fork end GK	86
Spherical bearing GA	87
High-performance joint head HG	87
Bellow FB	88 - 89
Spiral spring cover SF	90
Lubricants	91
Lubricant dispenser	92
3-phase motors	93 - 94
Handwheels	95 - 96
Motor adaptor flanges	97 - 98
Couplings	99 - 100
Universal joint shaft	101 - 103
Pedestal bearings	104
Bevel gearboxes	105 - 113
Ordering code Bevel gearboxes	114
<b>Installation and maintenance</b>	115
<b>Contact person</b>	117

# Overview

## NEFF Screw drives

### Trapezoidal screw drives

NEFF trapezoidal screws are manufactured from special semi-finished goods with high demands on straightness. The series conforms to DIN 103 and offers an extensive range of nuts made from various materials – all ready for installation. The very low backlash in the nuts allows low radial forces to be absorbed.

#### Trapezgewindespindeln

- Precision-rolled trapezoidal screws RPTS, Ø 10 – 80 mm in versions with single or multi-start threads.
- Planetary-milled trapezoidal screws WPTS, Ø 16 – 120 mm (the trapezoidal screws can also be supplied in coated and rustproof versions).

#### Trapezoidal nuts

- KSM, steel nut, round, Ø 10 – 80 mm
- SKM, steel nut, hexagonal, Ø 10 – 80 mm
- SFM, red bronze, ready to install, Ø 10 – 80 mm
- LRM, red bronze nut, Ø 10 – 80 mm
- EFM, red bronze, ready to install, Ø 10 – 80 mm
- Central flanged nut, bronze GBZ 12
- Central flanged nut, plastic, PTFE alloy
- Universal joint nut, bronze GBZ 12
- Universal joint nut, plastic, PTFE alloy
- Bracket nut, bronze GBZ 12
- Bracket nut, plastic, PTFE alloy

### Screw drive accessories

The NEFF screw drive accessory range offers an extensive range of accessories for all common accessory parts of a screw drive, from ready-to-install bearing units to the appropriate spindle grease. If desired we also manufacture tailor-made solutions in our modern machine pool.

- End machining
- Fixed bearing/movable bearing units
- Grooved nuts
- Adaptor brackets KON
- Pivot adaptors KAR
- Bellows FB
- Spiral spring covers SF
- Lubricant dispensers
- Grease cartridges

### Ball screw drives

The range conforms to DIN 69051 and the NEFF standard. All nuts (flanged and cylinder versions) can be supplied with the corresponding DIN connections. Pre-tensioned double-nut units achieve high positioning accuracies. Special nuts on enquiry. All ball screw drives are available with customer-specific end machining. On request we can supply soft-annealed ends for you to carry out your own end machining.

#### Ball screws

- Precision-rolled ball screws, Ø 12 – 80 mm  
Pitch from 5 - 50 mm, pitch accuracies of 23 µm, 50 µm and 200 µm/300 mm
- polished ball screws, Ø 6-120 mm,  
Pitch from 5 - 50 mm, pitch accuracies of 6-52 µm/300 mm

#### Ball nuts

- KGF-N NEFF flanged single nut
- KGF-D DIN DIN flanged single nut
- KGM-N NEFF cylinder single nut
- KGM-N DIN cylinder single nut
- KGM-E screw-in cylinder single nut  
(the ball nuts can also be supplied free of play and pre-tensioned in conjunction with spindles.)

# Overview

## NEFF Screw Jacks

### Worm Gear Screw Jacks

The range encompasses 11 sizes with lifting forces from 2.5 to 500 kN, with fixed and rotating spindles.

- Some sizes are available as standard with lifetime lubrication
- Significantly improved efficiency through optimisation of tolerances and surface quality
- Limited absorption of lateral forces through the use of the NEFF glide screw
- Optionally also available with ball screw or trapezoidal screw drive
- Mountable in any position thanks to the cubic design

### High-speed screw jacks

NEFF high-speed screw jacks supplement the existing screw jack range in the medium load range for high stroke speed and higher duty cycle.

- 3 sizes
- Gearboxes with ratios of 1:1, 2:1 and 3:1 available
- Hardened, polished and spiral-toothed bevel gearboxes
- Mountable in any position thanks to the cubic design
- Available with up to 4 output shafts (except transmission ratio 1:1)

### Screw jack accessories

The NEFF screw jack accessory range offers an extensive selection of accessories for all common accessory parts of a screw jack, from precise pivot bearings to the appropriate grease dispenser.

If desired we also manufacture tailor-made solutions in our modern machine pool.

- Bevel gearboxes
- Fastening strips BLL
- Pivot adaptors KA
- Pivot bearing flange
- Pivot bearing pedestal
- Mounting plate BP
- Limit switch
- Fork end GK
- Spherical bearing GA
- High-performance rod end HG
- Spiral spring cover SF
- Bellows FB
- Three-phase motors M
- Motor adaptor flanges MG
- Shaft coupling GS
- Shaft coupling RA, RG
- Universal joint shaft ZR
- Universal joint shaft GX
- Pedestal bearing SN
- Grease cartridges
- Lubricant dispensers
- Adaptor brackets KON
- Pivot adaptors KAR
- Bellows FB
- Spiral spring covers SF
- Lubricant dispensers
- Grease cartridges

## Ball screw drive

Ball screw drives from Neff screw drives are the result of many decades of innovative further development of the ball screw drive.

We offer ball screw drives in all common sizes in precision-rolled versions at competitive prices, in extraordinary quality and with a complete quality concept.

The Neff ball screw range corresponds to DIN 69051 and the NEFF standard (exchangeability of EFM trapezoidal nuts to ball screw nuts)

The spindles are available with customised end machining, or on request with soft-annealed ends for your own machining.

The high mechanical efficiency < 98% requires a lower drive power and a significantly lower breakaway torque than with trapezoidal screw drives.

Thanks to the low rolling friction and deflection systems that have been developed further over many years, Neff ball screw drives have a particularly long and reliable service life

### 2-start Neff ball screw drive with channel deflection:



# General technical data

## Manufacturing process

The thread profile of NEFF ball screws is produced by cold rolling in the thread rolling method. Both screw and nut have an arched thread profile. The load angle is 45°.

## Linear speeds

At present the permissible speed limit is in the region of 3000 rpm, with individual dimensions up to 4500 rpm. This limit defines the maximum speed, which may be run only under ideal operating conditions.

## Installation position

The position in which the screw drive is installed can always be freely chosen. Please consider that all radial forces that occur need to be absorbed by external guides.

## Accuracy classes of the spindles

T5 = pitch accuracy 23 µm/300 mm

T7 = pitch accuracy 52 µm/300 mm

T9 = pitch accuracy 130 µm/300 mm

T10 = pitch accuracy 200 µm/300 mm

If nothing different is specified we deliver class T7.

## Self-locking

Ball screw drives are generally not self-locking due to the low friction. It is therefore advisable to install suitable motors with holding brake, particularly when the ball screw drive is installed vertically.

## Efficiency

Trapezoidal screw drives have a max. mechanical efficiency of 50 %, ball screw drives achieve a mechanical efficiency of up to 98 %.

## Duty cycle

The ball screw drive permits a duty cycle of up to 100 %. Extremely high forces in combination with high duty cycles can shorten the service life.

## Temperatures

All screw drives are designed for continuous operation at ambient temperatures of -30 °C up to 80 °C. Temperatures of up to 110 °C are also permitted for brief periods. Ball screw drives are suitable only in exceptional cases for operation at sub-zero temperatures.

## Repeatability

The repeatability is defined as the capability of a screw drive to reach an actual position again that has been reached once before under the same conditions. It refers to the average position variation according to VDI/DGQ 3441. The repeatability is influenced amongst other things by:

- Load
- Speed
- Deceleration
- Direction of travel
- Temperature

## Aggressive operating conditions

In cases of heavy dirt and fine dust particles/swarf, an additional bellow or a spiral spring cover is recommended.

## Installation and maintenance

see page: 54

## Neff ball screw profiles

Neff ball screw profiles have a Gothic pointed arch profile with a 45° contact angle and optimised osculation. (Ratio of ball race radius to ball diameter)

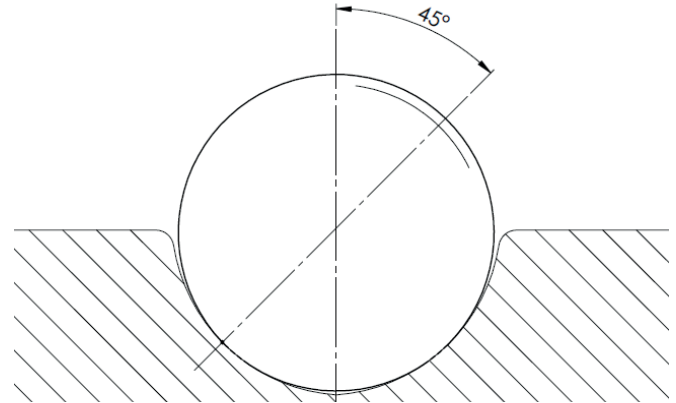

## Neff deflection systems

Single deflection:

In this type of deflection the balls are lifted up out of the spindle after each circuit and set back by one thread pitch. (Only for single-start ball screw drives)

Channel deflection:

In channel deflection the balls, after several circuits, are steered by an integrated deflection piece into a return channel in the nut and fed back (For single-start and multi-start ball screw drives)

Cover deflection:

In cover deflection the balls are steered via special deflection covers into the return channel in the nut and fed back. (For multi-start ball screw drives)

## Types of pre-loading:

In principle all Neff ball screw nuts are combinable for a backlash-free, O-pre-loaded nut unit if a ball screw drive is selected with a pitch accuracy of  $\leq T7$ .

With less accurate pitch classes only low-backlash can be set ( $\geq 0.03\text{mm}$ )

O-pre-loading:

In the O-pre-loading the force lines run with a diamond form, i.e. the nuts are pressed apart by a specially manufactured intermediate piece. The standard pre-loading is about 10% of the dynamic load rating  $C_{dyn}$

Pre-loading by ball selection:

The ball screw nut can be adjusted for low backlash by means of ball selection.

# Ball screws KGS

## Technical data ball screw KGS

- Diameter: \_\_\_\_\_ Standard: 12 – 80 mm
- Pitch: \_\_\_\_\_ Standard: 5 – 50 mm
- Number of starts: \_\_\_\_\_ 1 – 5
- Thread direction: \_\_\_\_\_ Right hand thread,  
KGS 2005 + 3205 also  
left hand thread
- Length: \_\_\_\_\_ Standard: 5600 mm  
KGS 1205: 2000 mm  
to 11000 mm auf Anfrage
- Material: \_\_\_\_\_ 1.1213 (Cf 53)  
Ball track inductively hardened  
and polished, Spindle end and  
spindle core soft
- Straightness: \_\_\_\_\_ L < 500 mm: 0,05 mm/m  
L = 500 – 1000 mm: 0,08 mm/m  
L > 1000 mm: 0,1 mm/m
- Right-hand/left-hand spindle: \_\_\_\_\_ KGS 2005 + 3205 only

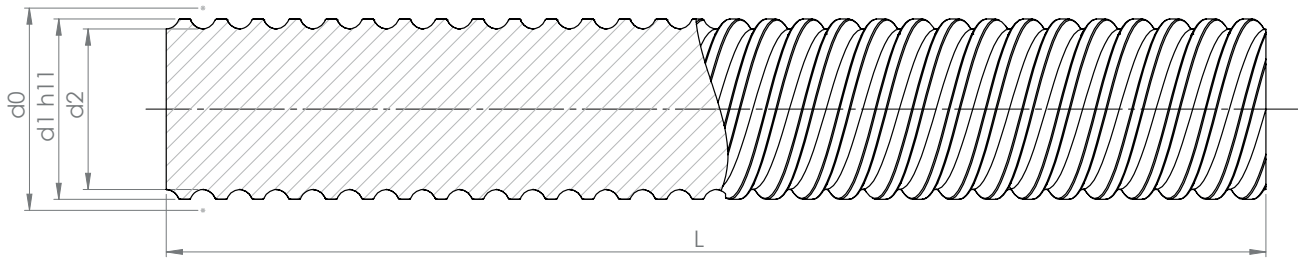

d0= nominal diameter, d1= outside diameter, d2= core diameter, L= spindle length

Type Diameter [mm] Pitch [mm] Right hand thread Division	Ball size	Dimensions [mm]				Distributed load $W_{KGS}$ [kg/m]	Geometrical moment of inertia $I_y$ [10 <sup>4</sup> mm <sup>4</sup> ]	Moment of resistance <sup>1)</sup> [10 <sup>3</sup> mm <sup>3</sup> ]	Mass moment of inertia [kg m <sup>2</sup> /m]
		d <sub>0</sub>	d <sub>1</sub>	d <sub>2</sub>	L max.				
KGS-1205	2	12	11.5	10.1	2000	0.75	0.051	0.101	1.13 · 10 <sup>-5</sup>
KGS-1605	3.5	16	15.5	12.9	5600	1.26	0.136	0.211	3.21 · 10 <sup>-5</sup>
KGS-1610-P5	3	16	15.4	13.0	5600	1.26	0.140	0.216	3.21 · 10 <sup>-5</sup>
KGS-1616-P8	3	16	15.4	13.0	5600	1.26	0.140	0.216	3.21 · 10 <sup>-5</sup>
KGS-2005	3.5	20	19.5	16.9	5600	2.04	0.400	0.474	8.46 · 10 <sup>-5</sup>
KGS-2020-P5	3.5	20	19.5	16.9	5600	2.04	0.400	0.474	8.46 · 10 <sup>-5</sup>
KGS-2050-P10	3.5	20	19.1	16.5	5600	2.04	0.364	0.441	8.46 · 10 <sup>-5</sup>
KGS-2505-P5	3.5	25	24.5	21.9	5600	3.33	1.129	1.031	2.25 · 10 <sup>-4</sup>
KGS-2510-P5	3.5	25	24.5	21.9	5600	3.33	1.129	1.031	2.25 · 10 <sup>-4</sup>
KGS-2520-P5	3.5	25	24.6	22.0	5600	3.33	1.150	1.045	2.25 · 10 <sup>-4</sup>
KGS-2525-P5	3.5	25	24.5	22.0	5600	3.33	1.150	1.045	2.25 · 10 <sup>-4</sup>
KGS-2550-P10	3.5	25	24.1	21.5	5600	3.33	1.049	0.976	2.25 · 10 <sup>-4</sup>
KGS-3205	3.5	32	31.5	28.9	5600	5.63	3.424	2.370	6.43 · 10 <sup>-4</sup>
KGS-3210	7.144	32	32.7	27.3	5600	5.63	2.727	1.998	6.43 · 10 <sup>-4</sup>
KGS-3220-P10	5	32	31.7	27.9	5600	5.63	2.974	2.132	6.43 · 10 <sup>-4</sup>
KGS-3240-P10	3.5	32	30.9	28.3	5600	5.63	3.149	2.225	6.43 · 10 <sup>-4</sup>
KGS-4005	3.5	40	39.5	36.9	5600	9.01	9.101	4.933	1.65 · 10 <sup>-3</sup>
KGS-4010	7.144	40	39.5	34.1	5600	8.35	6.737	3.893	1.41 · 10 <sup>-3</sup>
KGS-4020-P10	5	40	39.7	35.9	5600	9.01	8.154	4.542	1.65 · 10 <sup>-3</sup>
KGS-4040-P10	3.5	40	38.9	36.3	5600	9.01	8.523	4.696	1.65 · 10 <sup>-3</sup>
KGS-5010	7.144	50	49.5	44.1	5600	13.50	18.566	8.420	3.70 · 10 <sup>-3</sup>
KGS-5020-P10	7.144	50	49.5	44.1	5600	13.50	18.566	8.420	3.70 · 10 <sup>-3</sup>
KGS-6310	7.144	63	62.5	57.1	5600	22.03	52.181	18.280	9.84 · 10 <sup>-3</sup>
KGS-8010	7.144	80	79.65	74.2	5600	36.43	148.600	39.950	2.69 · 10 <sup>-2</sup>
Left hand thread									
KGS-2005 LH	3.5	20	19.5	16.9	5600	2.04	0.400	0.474	8.46 · 10 <sup>-5</sup>
KGS-2505 LH	3.5	25	24.5	21.9	5600	3.33	1.129	1.031	2.25 · 10 <sup>-4</sup>
KGS-3205 LH	3.5	32	31.5	28.9	5600	5.63	3.424	2.370	6.43 · 10 <sup>-4</sup>

<sup>1)</sup> The polar resistive torque is twice as large as the resistive torque



## Ordering code

### Ball screws

## Ordering code for ball screws

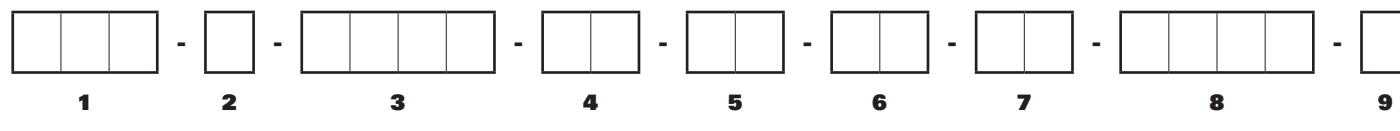

No.	Designation	Code	Description
<b>1</b>	Product abbreviation	<b>KGS</b>	Ball screw
<b>2</b>	Spindle abbreviation	<b>R</b>	Rolled
		<b>W</b>	Spun
		<b>S</b>	Grounded
<b>3</b>	Thread designation		e.g. 2005 (diameter 20 mm, pitch 5 mm)
<b>4</b>	Accuracy class of the spindle	<b>T5</b>	23µ/300 mm
		<b>T7</b>	50µ/300 mm
		<b>T9</b>	130µ/300 mm
		<b>T10</b>	200µ/300 mm
<b>5</b>	Pitch direction	<b>RH</b>	Right-hand thread
		<b>LH</b>	Left-hand thread
<b>6</b>	Spindle end A	<b>O</b>	Ends only sawn and brushed
<b>7</b>	Spindle end B	<b>A</b>	End with chamfer
		<b>GA</b>	1st end annealed (indicate length in the additional text)
		<b>GB</b>	2nd end annealed (indicate length in the additional text)
		<b>K</b>	End according to customer drawing or project drawing no.
		<b>D</b>	End fixed bearing form D for bearing ZKLF
		<b>F</b>	End fixed bearing form F for bearing ZARN
		<b>H</b>	End fixed bearing form H for bearing ZARF/LTN
		<b>J</b>	End fixed bearing form J for bearing FDX 12-40
		<b>L</b>	End fixed bearing form L for bearing 7201-7208
		<b>S</b>	End movable bearing form S for bearing 6001-6211
		<b>T</b>	End movable bearing form T for needle bearing HK1614-4518
		<b>W</b>	End movable bearing form W for bearing 6001-6211
		<b>Fk</b>	End fixed bearing unit FK4-FK30
		<b>FF</b>	End movable bearing unit FF6-FF30
		<b>BK</b>	End fixed bearing unit BK10-BK40
		<b>BF</b>	End movable bearing unit BF10-BF40
<b>M</b>	Metric threaded stem SHG		
<b>AS</b>	End hollowing safeguard SHG		
<b>RS</b>	End worm gear connection rotary spindle SHG		
<b>VS</b>	End anti-twist device SHG		
<b>Z</b>	cylindrical bearing journal SHG with rotary spindle		
<b>8</b>	Overall length in (mm)		e.g. 1000
<b>9</b>	Special requirements	<b>0</b>	None
		<b>1</b>	According to specification, description or drawing

# Flanged ball nuts KGF-D

according to DIN 69051

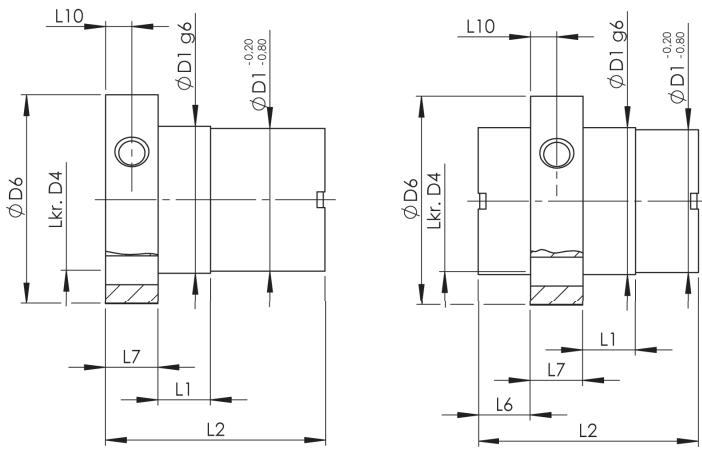

Form E

Form S

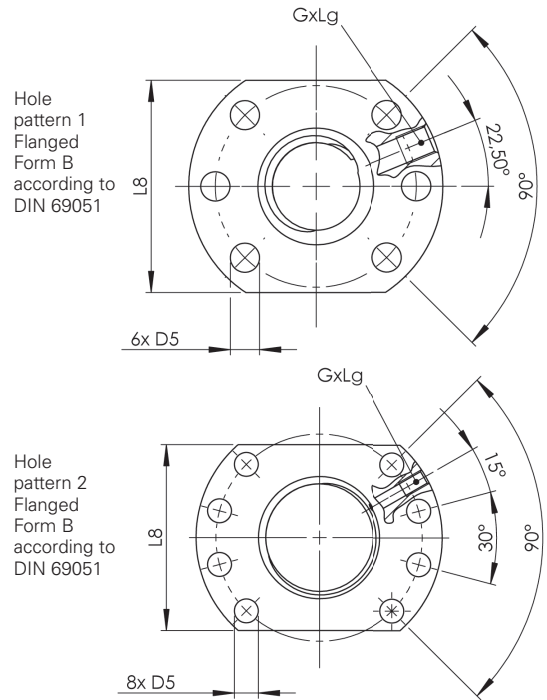
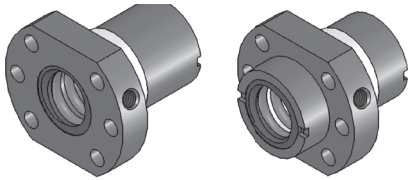

Material: 1.7131 (ESP65) or 1.3505 (100 Cr 6)

Type Diameter [mm] Pitch [mm] Right-hand thread	Form	Bore pattern	Dimensions [mm]											Lubrication bore G	Axial backlash max [mm]	No. of circuits	Load rating [kN]		
			D <sub>1</sub>	D <sub>4</sub>	D <sub>5</sub>	D <sub>6</sub>	L <sub>1</sub>	L <sub>2</sub>	L <sub>6</sub>	L <sub>7</sub>	L <sub>8</sub>	L <sub>9</sub>	L <sub>10</sub>				C <sup>2)</sup>	C <sup>3)</sup>	C <sub>0</sub> = C <sub>0a</sub>
KGF-D 1605 RH-EE	E	1	28	38	5.5	48	10	42	-	10	40	10	5	M 6	0.08	3	12.0	9.3	13.1
KGF-D 1610 RH-EE	E	1	28	38	5.5	48	10	55	-	10	40	10	5	M 6	0.08	6	23.0	15.4	26.5
KGF-D 1616-P8-3 RH-EE	E	1	28	38	5.5	48	10	55	-	10	40	10	5	M 6	0,08	6	23,0	15,4	26,5
KGF-D 1640-P10-3 RH-EE	S	1	32	42	5.5	52	10	45	10	10	40	8	5	M6	0,08	4	-	8,5	13
KGF-D 2005 RH-EE	E	1	36	47	6.6	58	10	42	-	10	44	10	5	M 6	0.08	3	14.0	10.5	16.6
KGF-D 2505 RH-EE	E	1	40	51	6.6	62	10	42	-	10	48	10	5	M 6	0.08	3	15.0	12.3	22.5
KGF-D 2510 RH-EE	E	1	40	51	6.6	62	16	55	-	10	48	10	5	M 6	0.08	3	17.5	13.2	25.3
KGF-D 2520 RH-EE	S	1	40	51	6.6	62	4	35	10.5	10	48	8	5	M 6	0.15	4	19.0	13.0	23.3
KGF-D 2525 RH-EE	S	1	40	51	6.6	62	9	35	8	10	48	8	5	M 6	0.08	5	21.0	16.7	32.2
KGF-D 2550 RH-EE	S	1	40	51	6.6	62	10	58	10.0	10	48	8	5	M 6	0.15	5	22.5	15.4	31.7
KGF-D 3205 RH-EE	E	1	50	65	9	80	10	55	-	12	62	10	6	M 6	0.08	5	24.0	21.5	49.3
KGF-D 3210 RH-EE <sup>5)</sup>	E	1	53 <sup>1)</sup>	65	9	80	16	69	-	12	62	10	6	M 8x1	0.08	3	44.0	33.4	54.5
KGF-D 3220 RH-EE	E	1	53 <sup>1)</sup>	65	9	80	16	80	-	12	62	10	6	M 6	0.08	4	42.5	29.7	59.8
KGF-D 3260-P10-3,5 RH-EE	S	1	53	65	9	80	16	68	10	12	62	10	6	M 6	0,08	4,8	-	20	49,3
KGF-D 4005 RH-EE	E	2	63	78	9	93	10	57	-	14	70	10	7	M 6	0.08	5	26.0	23.8	63.1
KGF-D 4010 RH-EE	E	2	63	78	9	93	16	71	-	14	70	10	7	M 8x1	0.08	3	50.0	38.0	69.1
KGF-D 4020 RH-EE	E	2	63	78	9	93	16	80	-	14	70	10	7	M 8x1	0.08	4	44.5	33.3	76.1
KGF-D 4040 RH-EE	S	2	63	78	9	93	16	85	7.5	14	- <sup>4)</sup>	10	7	M 8x1	0.08	8	42.0	35.0	101.9
KGF-D 5010 RH-EE	E	2	75	93	11	110	16	95	-	16	85	10	8	M 8x1	0.08	5	78.0	68.7	155.8
KGF-D 5020 RH-EE	E	2	85 <sup>1)</sup>	103 <sup>1)</sup>	11	125	22	95	-	18	95	10	9	M 8x1	0.08	4	82.0	60.0	136.3
KGF-D 6310 RH-EE	E	2	90	108	11	125	16	97	-	18	95	10	9	M 8x1	0.08	5	86.0	76.0	197
KGF-D 8010 RH-EE	E	2	105	125	13.5	145	16	99	-	20	110	10	10	M 8x1	0.08	5	-	82.7	221.9
Left-hand thread																			
KGF-D 2005 LH-EE	E	1	36	47	6.6	58	10	42	-	10	44	10	5	M 6	0.08	3	16.5	10.5	16.6

<sup>1)</sup> D<sub>1</sub> not conforming to DIN 69051.

<sup>2)</sup> Dynamic load rating according to DIN 69051 part 4 draft 1978.

<sup>3)</sup> Dynamic load rating according to DIN 69051 part 4 draft 1989.

<sup>4)</sup> Round flange.

<sup>5)</sup> Also available with Ø 50 mm according to DIN.

# Flanged ball nuts KGF-N according to NEFF standard

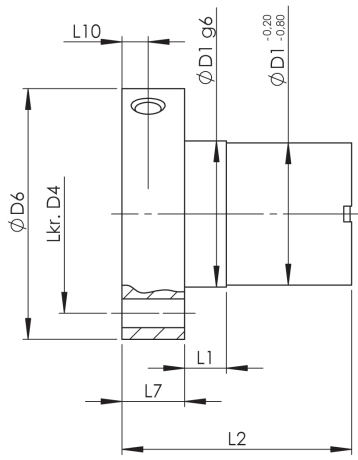

Form E

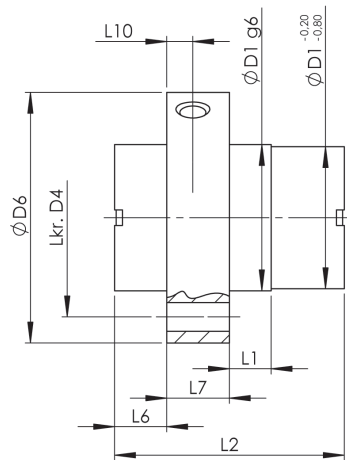

Form S

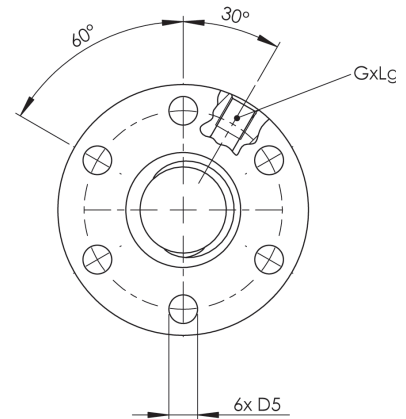

Bore pattern 3  
Neff standard

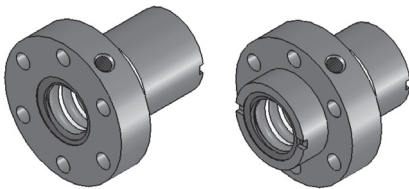

Material: 1.7131 (ESP65) or 1.3505 (100 Cr 6)

Type Diameter [mm] Pitch [mm] Right-hand thread	Form	Dimensions [mm]										Lubrication bore G	Axial backlash max [mm]	No. of circuits	Load rating [kN]		
		D <sub>1</sub>	D <sub>4</sub>	D <sub>5</sub>	D <sub>6</sub>	L <sub>1</sub>	L <sub>2</sub>	L <sub>6</sub>	L <sub>7</sub>	L <sub>9</sub>	L <sub>10</sub>				C <sup>1)</sup>	C <sup>2)</sup>	C <sub>0</sub> = C <sub>0a</sub>
KGF-N 1605 RH-EE	E	28	38	5.5	48	8	44	–	12	8	6	M 6	0.08	3	12.0	9.3	13.1
KGF-N-1616-P8-3-RH-EE	E	28	38	5,5	48	8	45	–	12	8	6	M 6	0.08	3,75	–	10	16,4
KGF-N 2005 RH-EE	E	32	45	7	55	8	44	–	12	8	6	M 6	0.08	3	14.0	10.5	16.6
KGF-N 2020 RH-EE	S	35	50	7	62	4	30	8	10	8	5	M 6	0.08	4	12.0	11.6	18.4
KGF-N 2050 RH-EE	S	35	50	7	62	10	56	8	10	8	5	M 6	0.15	5	18.0	13.0	24.6
KGF-N 2505 RH-EE	E	38	50	7	62	8	46	–	14	8	7	M 6	0.08	3	15.0	12.3	22.5
KGF-N 3205 RH-EE	E	45	58	7	70	10	59	–	16	8	8	M 6	0.08	5	24.0	21.5	49.3
KGF-N 3210 RH-EE	E	53	68	7	80	10	73	–	16	8	8	M 8x1	0.08	3	44.0	33.4	54.5
KGF-N 3240 RH-EE	S	53	68	7	80	14	45	7.5	16	10	8	M 6	0.08	4	17.0	14.9	32.4
KGF-N-3260-P10-3,5 RH-EE	E	53	68	7	80	16	68	10	16	8	8	M 6	0,08	4,8	–	20	49,3
KGF-N 4005 RH-EE	E	53	68	7	80	10	59	–	16	8	8	M 6	0.08	5	26.0	23.8	63.1
KGF-N 4010 RH-EE	E	63	78	9	95	10	73	–	16	8	8	M 8x1	0.08	3	50.0	38.0	69.1
KGF-N 5010 RH-EE	E	72	90	11	110	10	97	–	18	8	9	M 8x1	0.08	5	78.0	68.7	155.8
KGF-N 6310 RH-EE	E	85	105	11	125	10	99	–	20	8	10	M 8x1	0.08	5	86.0	76.0	197.0
KGF-N 8010 RH-EE	E	105	125	13.5	145	10	101	–	22	8	11.5	M 8x1	0.08	5	-	82.7	221.9

<sup>1)</sup> Dynamic load rating according to DIN 69051 part 4 draft 1978.

<sup>2)</sup> Dynamic load rating according to DIN 69051 part 4 draft 1989.

# Cylindrical ball nuts

## KGM-D

according to DIN 69051

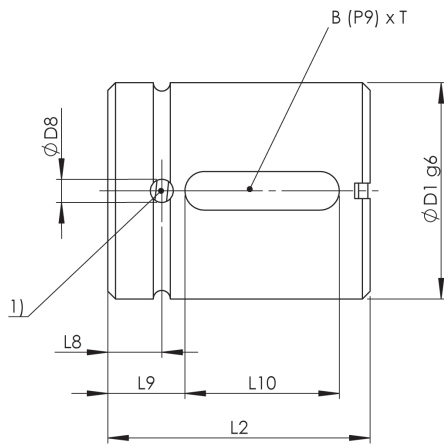

Form E

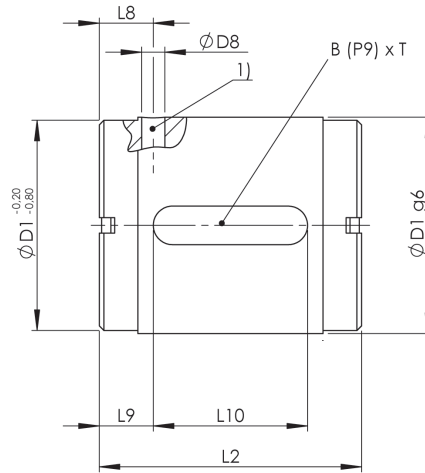

Form S

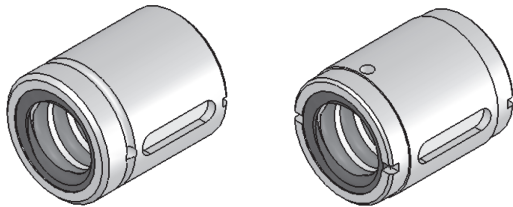

<sup>1)</sup> Position of the lubrication bore not defined

Material: 1.7131 (ESP65) or 1.3505 (100 Cr 6)

Type Diameter [mm] Pitch [mm] Right-hand thread	Form	Dimensions [mm]							Axial backlash max [mm]	No. of circuits	Load rating [kN]		
		$D_1$	$D_8$	$L_2$	$L_8$	$L_9$	$L_{10}$	BxT			$C^{2)}$	$C^{3)}$	$C_0 = C_{0a}$
KGM-D 1605 RH-EE	E	28	3	34	7	7	20	5x2	0,08	3	12,5	9,3	13,1
KGM-D 1610 RH-EE	E	28	3	50	7	15	20	5x2,2	0,08	6	23,0	15,4	26,5
KGM-D-1616-P8	E	28	3	45	7	12,5	20	5x2,2	0,08	3,75	–	10	16,4
KGM-D 1640-P10-3 RH-EE	E	28	1,5	45	14,5	17,5	10	5x2	0,08	4	–	8,5	13
KGM-D 2005 RH-EE	E	36	3	34	7	7	20	5x2	0,08	3	14,0	10,5	16,6
KGM-D 2505 RH-EE	E	40	3	34	7	7	20	5x2	0,08	3	15,0	12,3	22,5
KGM-D 2510 RH-EE	E	40	3	45	7,5	12,5	20	5x2	0,08	3	17,5	13,2	25,3
KGM-D 2520 RH-EE	S	40	1,5	35	14	11,5	12	5x3	0,15	4	19,0	13,0	23,3
KGM-D 2525 RH-EE	S	40	1,5	35	11,5	11	13	5x3	0,08	5	21,0	16,7	32,2
KGM-D 2550 RH-EE	S	40	1,5	58	17	19	20	5x3	0,15	5	22,5	15,4	31,7
KGM-D 3205 RH-EE	E	50	3	45	7,5	8	30	6x2,5	0,08	5	24,0	21,5	49,3
KGM-D 4005 RH-EE	E	63	3	45	7,5	8	30	6x2,5	0,08	5	26,0	23,8	63,1
KGM-D 4010 RH-EE	E	63	4	60	10	15	30	6x2,5	0,08	3	50,0	38,0	69,1
KGM-D 4020 RH-EE	E	63	3	70	7,5	20	30	6x2,5	0,08	4	44,5	33,3	76,1
KGM-D 4040 RH-EE	S	63	1,5	85	15	27,5	30	6x3,5	0,08	8	42,0	35,0	101,9
KGM-D 5010 RH-EE	E	75	4	82	11	23	36	6x2,5	0,08	5	78,0	68,7	155,8
KGM-D 6310 RH-EE	E	90	4	82	11	23	36	6x2,5	0,08	5	86,0	76,0	197,0
Left-hand thread													
KGM-D 2005 LH-EE	E	36	3	34	7	7	20	5x2	0,08	3	16,5	10,5	16,6

<sup>1)</sup> Position of the lubrication bore not defined.

<sup>2)</sup> Dynamic load rating according to DIN 69051 part 4 draft 1978.

<sup>3)</sup> Dynamic load rating according to DIN 69051 part 4 draft 1989.

# Cylindrical ball nuts KGM-N according to NEFF standard

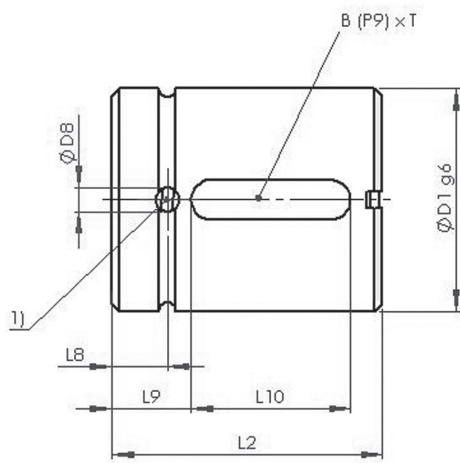

Form E

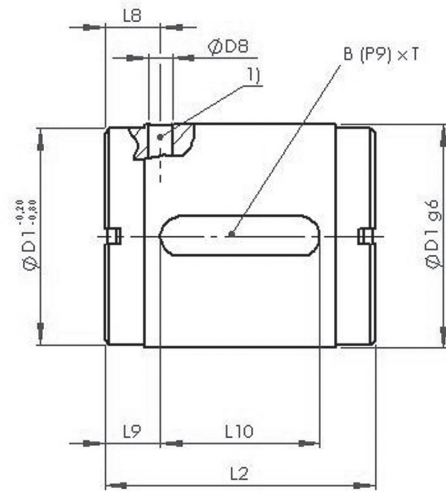

Form S

<sup>1)</sup> Position of the lubrication bore not defined

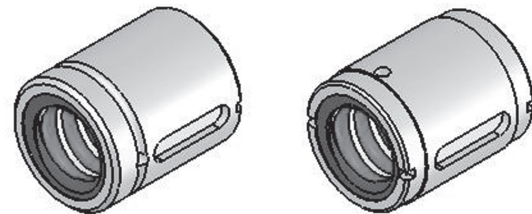

Material: 1.7131 (ESP65) or 1.3505 (100 Cr 6)

Type Diameter [mm] Pitch [mm] Right-hand thread	Form	Dimensions [mm]							Axial backlash max [mm]	No. of circuits	Load rating [kN]		
		$D_1$	$D_8$	$L_2$	$L_8$	$L_9$	$L_{10}$	BxT			$C^{(2)}$	$C^{(3)}$	$C_0 = C_{0a}$
KGM-N 1205 RH-00	E	20 <sup>4)</sup>	–	24	–	5	14	3x1.8	0.08	3	6.0	4.4	6.8
KGM-N 2005 RH-EE	E	32	3	34	7	7	20	5x2	0.08	3	14.0	10.5	16.6
KGM-N 2020 RH-EE	S	35	1.5	30	11.5	9	12	5x3	0.08	4	12.0	11.6	18.4
KGM-N 2050 RH-EE	S	35	1.5	56	16	18	20	5x2.2	0.15	5	18.0	13.0	24.6
KGM-N 2505 RH-EE	E	38	3	34	7	7	20	5x2	0.08	3	15.0	12.3	22.5
KGM-N 3205 RH-EE	E	45	3	45	7.5	8	30	6x2.5	0.08	5	24.0	21.5	49.3
KGM-N 3210 RH-EE	E	53	4	60	10	15	30	6x2.5	0.08	3	44.0	33.4	54.5
KGM-N 3220 RH-EE	E	53	3	70	7.5	20	30	6x2.5	0.08	4	42.5	29.7	59.8
KGM-N 3240 RH-EE	S	53 <sup>5)</sup>	1.5	45	13	10	25	6x4	0.08	4	17.0	14.9	32.4
KGM-N-3260-P10-3,5 RH-EE	S	53	1,5	68	15,5	21,5	25	6x2,5	0,08	4,8	–	19,8	46,6
KGM-N 4005 RH-EE	E	53	3	45	7.5	8	30	6x2.5	0.08	5	26.0	23.8	63.1
KGM-N 5010 RH-EE	E	72	4	82	11	23	36	6x2.5	0.08	5	78.0	68.7	155.8
KGM-N 5020 RH-EE	E	85	4	82	10	23	36	6x2.5	0.08	4	82.0	60.0	136.3
KGM-N 6310 RH-EE	E	85	4	82	11	23	36	6x2.5	0.08	5	86.0	76.0	197.0
KGM-N 8010 RH-EE	E	105	4	82	11	23	36	8x3	0.08	5	-	82.7	221.9

<sup>1)</sup> Position of the lubrication bore not defined.

<sup>2)</sup> Dynamic load rating according to DIN 69051 part 4 draft 1978.

<sup>3)</sup> Dynamic load rating according to DIN 69051 part 4 draft 1989.

<sup>4)</sup> Nut without wiper.

<sup>5)</sup>  $D_1 -0,2/-0,8$  does not apply, therefore  $D_1 -1,0/-1,5$ .

# Ball nuts KGM-E

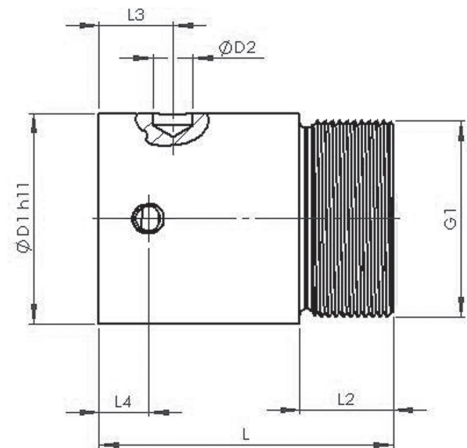
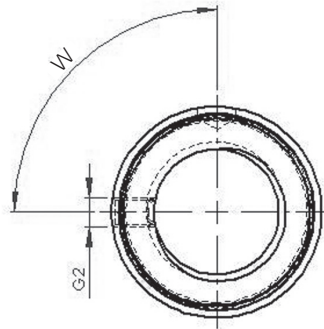

Material: 1.7131 (ESP65) or 1.3505 (100 Cr 6)

Size	Dimensions [mm]								
	D1h11	D2	L	L2	L3	L4	G1	G2	W
KGM-E-1605-RH	32	3.2	42	12	3		M26x1.5		
KGM-E-2005-RH	38	8	45	14	8	8	M35x1.5	M6	90°
KGM-E-2505-RH	43	8	60	19	15	10	M40x1.5	M6	90°
KGM-E-2510-RH	43	8	74	19	16	16	M40x1.5	M6	180°
KGM-E-3205-RH	52	8	63	19	15	10	M48x1.5	M6	90°
KGM-E-3210-RH	54	8	78	19	8	8	M48x1.5	M6	90°
KGM-E-4005-RH	60	8	63	19	15	10	M56x1.5	M8x1	90°
KGM-E-4010-RH	65	8	84	24	15	8	M60x2	M8x1	90°
KGM-E-5010-RH	78	8	111	29	15	8	M72x2	M8x1	90°

## Ordering code for ball nuts

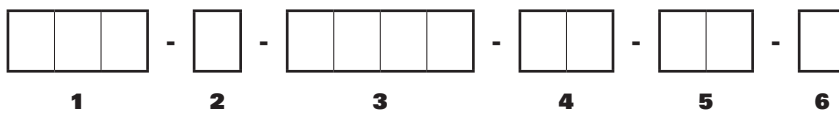

No.	Designation	Code	Description
1	Product abbreviation	<b>KGF</b>	Flanged ball nuts
		<b>KGM</b>	Cylindrical ball nuts
2	Nut version	<b>D</b>	Nut according to DIN 69051 standard
		<b>N</b>	Nut according to NEFF standard
		<b>E</b>	Nut with screw-in thread
		<b>S</b>	Nut with special dimensions
3	Thread designation		e.g. 2005 (diameter 20 mm, pitch 5mm)
4	Pitch direction	<b>RH</b>	Right-hand thread
		<b>LH</b>	Left-hand thread
5	Seal	<b>0</b>	without wiper
		<b>EE</b>	with double-sided wiper
6	Special requirements	<b>0</b>	None
		<b>1</b>	According to specification, description or drawing

# Ordering code

Ball screw

## Ordering code for ball screw

<b>1</b>	<b>2</b>	<b>3</b>	<b>4</b>	<b>5</b>	<b>6</b>	<b>7</b>	<b>8</b>	<b>9</b>	<b>10</b>	<b>11</b>	<b>12</b>	

No.	Designation	Code	Description
<b>1</b>	Product abbreviation	<b>KGT</b>	Ball screw
<b>2</b>	Spindle abbreviation	<b>R</b>	Rolled
		<b>W</b>	Spun
		<b>S</b>	Grounded
<b>3</b>	Spindle designation		e.g. 2005 (diameter 20 mm, pitch 5 mm)
<b>4</b>	Accuracy class of the spindle	<b>T5</b>	23µ/300 mm
		<b>T7</b>	50µ/300 mm
		<b>T9</b>	130µ/300 mm
		<b>T10</b>	200µ/300 mm
<b>5</b>	Pitch direction	<b>RH</b>	Right-hand thread
		<b>LH</b>	Left-hand thread
<b>6</b>	Spindle end A	<b>O</b> <b>A</b> <b>GA</b> <b>GB</b> <b>K</b> <b>D</b> <b>F</b> <b>H</b> <b>J</b> <b>L</b> <b>S</b> <b>T</b> <b>W</b> <b>Fk</b> <b>FF</b> <b>BK</b> <b>BF</b> <b>M</b> <b>AS</b> <b>RS</b> <b>VS</b> <b>Z</b>	Ends only sawn and brushed
<b>7</b>	Spindle end B		End with chamfer
			1st end annealed (indicate length in the additional text)
			2nd end annealed (indicate length in the additional text)
			End according to customer drawing or project drawing no.
			End fixed bearing form D for bearing ZKLF
			End fixed bearing form F for bearing ZARN
			End fixed bearing form H for bearing ZARF/LTN
			End fixed bearing form J for bearing FDX 12-40
			End fixed bearing form L for bearing 7201-7208
			End movable bearing form S for bearing 6001-6211
			End movable bearing form T for needle bearing HK1614-4518
			End movable bearing form W for bearing 6001-6211
<b>8</b>	Overall length in (mm)		e.g. 1000
<b>9</b>	Special requirements spindle	<b>O</b>	none
		<b>1</b>	According to specification, description or drawing
<b>10</b>	Ball nut or nut unit with installation note	<b>M</b>	Single nut, cylindrical
		<b>MM</b>	Nut unit, cylindrical, pre-loaded
		<b>FO</b>	Flanged single nut (flange to fixed bearing or longer end)
		<b>OF</b>	Flanged single nut (flange to movable bearing or shorter end)
		<b>FM</b>	Nut unit flanged nut + cylinder nut (flange to fixed bearing or longer end)
		<b>MF</b>	Nut unit flanged nut + cylinder nut (flange to movable bearing or shorter end)
		<b>FF</b>	Nut unit flanged nut + flanged nut
		<b>EO</b>	Single nut with screw-in thread (thread to fixed bearing or longer end)
<b>11</b>	Nut version	<b>OE</b>	Single nut with screw-in thread (thread to movable bearing or shorter end)
		<b>D</b>	Nut with DIN 69051 dimensions
		<b>N</b>	Nut with Neff dimensions
<b>12</b>	Special requirements for nut	<b>S</b>	Nut with special dimensions (according to drawing)
		<b>O</b>	none
		<b>1</b>	According to specification, description or drawing

# Calculation

## Ball screw Drive

### Required drive torque and drive power

The required drive moment of a screw drive results from the acting axial load, the thread pitch and the efficiency of the screw drive and its bearing. In case of short acceleration times and high speeds the acceleration torque must be checked.

Fundamentally it must be noted that trapezoidal screw drives have to overcome a breakaway torque when starting up.

### Required drive torque

(XV)

$$M_d = \frac{F_{ax} \cdot P}{2000 \cdot \pi \cdot \eta_A} = + M_{rot}$$

$F_{ax}$  Total acting axial force [N]  
 $P$  Thread pitch [mm]  
 $\eta_A$  Efficiency of the complete drive

$$= \eta_{KGT} \cdot \eta_{Ball \text{ screw drive}} \cdot \eta_{Fixed \text{ bearing}}$$

$$\eta_{KGT} (\mu = 0.1) = 0.9 \dots 0.95$$

$$\eta_{Movable \text{ flange}} = 0.95$$

$M_d$  Required drive torque [Nm]  
 $M_{rot}$  Rotary acceleration torque [Nm]

$$= J_{rot} \cdot \alpha_0 = 7.7 \cdot d^4 \cdot L \cdot 10^{-13}$$

$J_{rot}$  Rotary moment of inertia [kgm<sup>2</sup>]

$d$  Nominal spindle diameter [mm]

$L$  Spindle length [mm]

$\alpha_0$  Angular acceleration [1/s<sup>2</sup>]

### Drive power

(XVII)

$$P_a = \frac{M_d \cdot n}{9550}$$

$M_d$  Required drive torque [Nm]  
 $n$  Spindle speed [1/min]  
 $P_a$  Required drive power [kW]



## Calculation

### Ball screw Drive

#### Service life L

The (nominal) service life of a ball screw is calculated in the same way as the service life of a ball bearing.

#### Average speed

(I)

$$n_m = \frac{n_1 \cdot q_1 + n_2 \cdot q_2 + \dots + n_i \cdot q_i}{100}$$

#### Dynamic equivalent axial load (II)

$$F_m = \sqrt[3]{F_1^3 \cdot \frac{n_1 \cdot q_1}{n_m \cdot 100} + F_2^3 \cdot \frac{n_2 \cdot q_2}{n_m \cdot 100} + \dots + F_i^3 \cdot \frac{n_i \cdot q_i}{n_m \cdot 100}}$$

#### Service life of the ball screw (III)

in rollovers

$$L_{10} = \left( \frac{C}{F_m} \right)^3 \cdot 10^6$$

in hours

$$L_h = \frac{L_{10}}{n_m \cdot 60}$$

#### Calculation of the average force $F_m$

Similar to the single nut

#### Service life L

(IV)

$$L = \left( F_{m1}^{\frac{10}{3}} + F_{m2}^{\frac{10}{3}} \right)^{-0.9} \cdot C^3 \cdot 10^6$$

The calculation methods are only valid under perfect lubrication conditions. The service life can be reduced considerably in case of dirt or a lack of lubricant. Also, a shortening of the service life is to be expected with very short strokes. In these cases please consult our product advisors.

#### Caution!

**Ball screws can absorb neither radial forces nor pull-out torques**

#### Caution!

Note that vibrations and impact loads can negatively affect the service life of the ball screw

$n_1, n_2, \dots$  Speeds in [rpm] during the interval  $q_1, q_2, \dots$

$n_m$  Average speed in [1/min]

$q_1, q_2, \dots$  Percentage of the loading period in one load direction in [%]

$F_1, F_2, \dots$  Axial loads in [N] in one load direction during the interval  $q_1, q_2, \dots$

$F_m$  Dynamic equivalent axial load

Since a ball screw can be loaded in two directions,  $F_m$  must initially be determined for each of the two load directions. The larger value is then taken for the calculation of L.

In general it is useful to prepare a diagram. In doing so, remember that any pre-loading represents a constant load.

C Axial, dynamic load rating

Centrally acting load in [N] of a constant size and direction, with which a sufficient large number of identical ball screws achieved a service life of 106 revolutions.

$L_{10}$

Service life of the ball screw, expressed in the number of rollovers achieved by 90% ( $L_{10}$ ) of a sufficiently large number of obviously identical ball screws before the first signs of material fatigue appear.

#### Service life of a ball screw with a pre-loaded nut system

The pre-loading force of the nut unit acts as constant load on the ball screw.

$F_{m1}, F_{m2}, \dots$  Dynamic equivalent axial load of the first or second nut respectively [N].

C Axial, dynamic load rating

Centrally acting load in [N] of a constant size and direction, with which a sufficient large number of identical ball screws achieved a service life of 106 revolutions.

# Calculation

## Ball screw

### Example calculation

#### Lifetime of a ball screw

##### Given:

$F_1 = 30000 \text{ N}$  at  $n_1 = 150 \text{ 1/min}$  for  $q_1 = 21 \%$  of the duration of operation  
 $F_2 = 18000 \text{ N}$  at  $n_2 = 1000 \text{ 1/min}$  for  $q_2 = 13 \%$  of the duration of operation  
 $F_3 = 42000 \text{ N}$  at  $n_3 = 75 \text{ 1/min}$  for  $q_3 = 52 \%$  of the duration of operation  
 $F_4 = 1800 \text{ N}$  at  $n_4 = 2500 \text{ 1/min}$  for  $q_4 = 14 \%$  of the duration of operation  
 $\Sigma = 100 \%$

##### Required:

Maximum attainable service life under the given switch-on conditions.  
 Ball screw KGT 5010

#### Average spindle speed $n_m$ from (I)

$$n_m = \frac{n_1 \cdot q_1 + n_2 \cdot q_2 + n_3 \cdot q_3 + n_4 \cdot q_4}{100}$$

$$n_m = \frac{150 \cdot 21 + 1000 \cdot 13 + 75 \cdot 52 + 2500 \cdot 14}{100} \text{ 1/min}$$

→  $n_m = 550.5 \text{ 1/min}$

#### Dynamic equivalent axial load $F_m$ from (II)

$$F_m = \sqrt[3]{F_1^3 \cdot \frac{n_1 \cdot q_1}{n_m \cdot 100} + F_2^3 \cdot \frac{n_2 \cdot q_2}{n_m \cdot 100} + F_3^3 \cdot \frac{n_3 \cdot q_3}{n_m \cdot 100} + F_4^3 \cdot \frac{n_4 \cdot q_4}{n_m \cdot 100}}$$

$$F_m = \sqrt[3]{30000^3 \cdot \frac{150 \cdot 21}{550.5 \cdot 100} + 18000^3 \cdot \frac{1000 \cdot 13}{550.5 \cdot 100} + 42000^3 \cdot \frac{75 \cdot 52}{550.5 \cdot 100} + 1800^3 \cdot \frac{2500 \cdot 14}{550.5 \cdot 100}} \text{ N}$$

$F_m = 18943 \text{ N}$

#### Service life of the ball screw $L_{10}$ from (III)

$$L_{10} = \left( \frac{C}{F_m} \right)^3 \cdot 10^6 \quad \text{Dynamic load rating } C = 68700 \text{ N}$$

$$L_{10} = \left( \frac{68700}{18943} \right)^3 \cdot 10^6 \quad \text{Number of rollovers } L_{10}$$

$$L_{10} = 47,7 \cdot 10^6$$

$$L_h = \frac{L_{10}}{n_m \cdot 60} = \frac{47,7 \cdot 10^6}{550.5 \cdot 60} = 1444 \text{ h} \quad \text{Service life in hours } L_h$$

**Result** Under the given loads the selected screw drive has a total service life of  $47,7 \cdot 10^6$  rollovers, which corresponds to a timespan of 1444 hrs.

# Calculation

## Ball screw

### Types of bearing

Typical values for the correction factor  $f_k$  according to the classic installation cases for standard spindle bearings.

### Neff bearing case I

Fixed bearing – loose end, correction factor  $f_k=0.25 / f_{kr}=0.43$

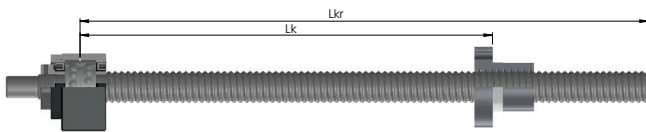

### Neff bearing case II

Movable bearing – movable bearing, correction factor  $f_k=1 / f_{kr}=1.21$

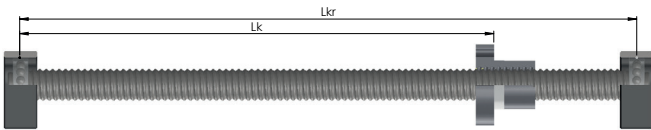

### Neff bearing case III

Fixed bearing – movable bearing, correction factor  $f_k=2.05 / f_{kr}=1.89$

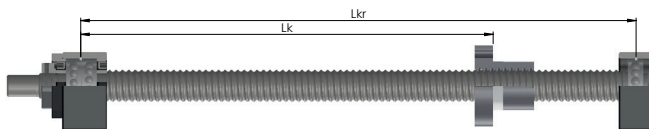

### Neff bearing case IV

Fixed bearing – fixed bearing, correction factor  $f_k=4 / f_{kr}=2.74$

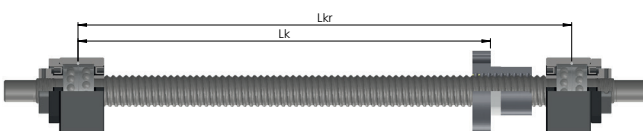

### Critical buckling force of ball screws

With slim components such as spindles there is a danger of lateral buckling under axial compressive loads. Using the procedure described below, the permissible, axial force can be determined according to Euler. The safety factors applying to the system must be considered before determining the permissible compressive force.

### Theoretically critical buckling force in [kN]:

$$F_k = \left( \frac{d_2}{L_k} \right)^4 \cdot 10^5 : 1000$$

### Maximum permissible axial force in:

$$F_{zul} = F_k \cdot f_k \cdot \frac{1}{S_f}$$

$F_{zul}$	Maximum permissible axial force [kN]
$F_k$	Theoretically critical buckling force [kN]
$f_k$	Correction factor that takes into account the type of spindle bearing
$d_2$	Core diameter of the spindle [mm]
$L_k$	Unsupported length on which the force acts on the spindle [mm]
$S_f$	Safety factor (specified by the user)

### Caution!

The operating force must not exceed 80% of the maximum permissible axial force

### Critical speed of ball screws

With slim, rotating components such as spindles there is a risk of resonant vibration. The procedure described below enables the resonant frequency to be estimated, assuming an adequately rigid installation. In addition, speeds close to the critical speed greatly increase the risk of lateral buckling. The critical speed must therefore also be considered in connection with the critical buckling force.

### Theoretically critical speed in [rpm]

$$n_{kr} = \left( \frac{d_2}{L_{kr}} \right)^2 \cdot 10^8$$

$n_{zul}$	Maximum permissible spindle speed [1/min]
$n_{kr}$	Theoretically critical spindle speed [rpm] that leads to resonant vibrations
$f_{kr}$	Correction factor that takes into account the type of spindle bearing
$d_2$	Core diameter of the spindle [mm]
$L_{kr}$	unsupported spindle length [mm]

### Caution!

The operating force must not exceed 80% of the maximum permissible axial force

### Maximum permissible speed of rotation in [rpm]

$$f_{kr} = F_{kr} \cdot f_k \cdot 0,8$$

# Calculation

## Ball screw

### Theoretically permissible buckling force:

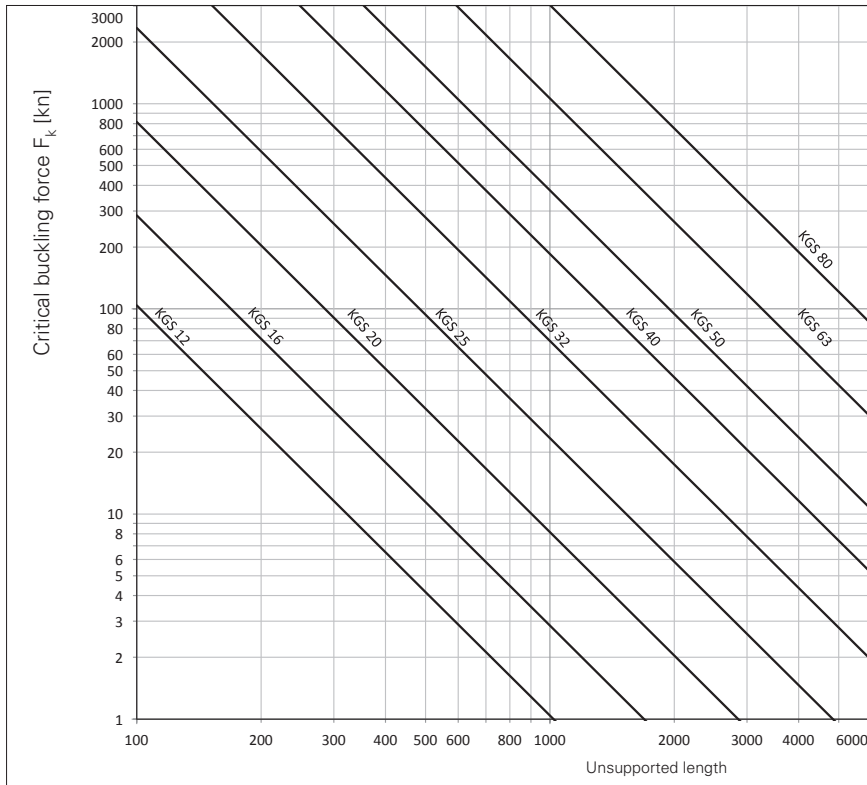

### Theoretically permissible speed:

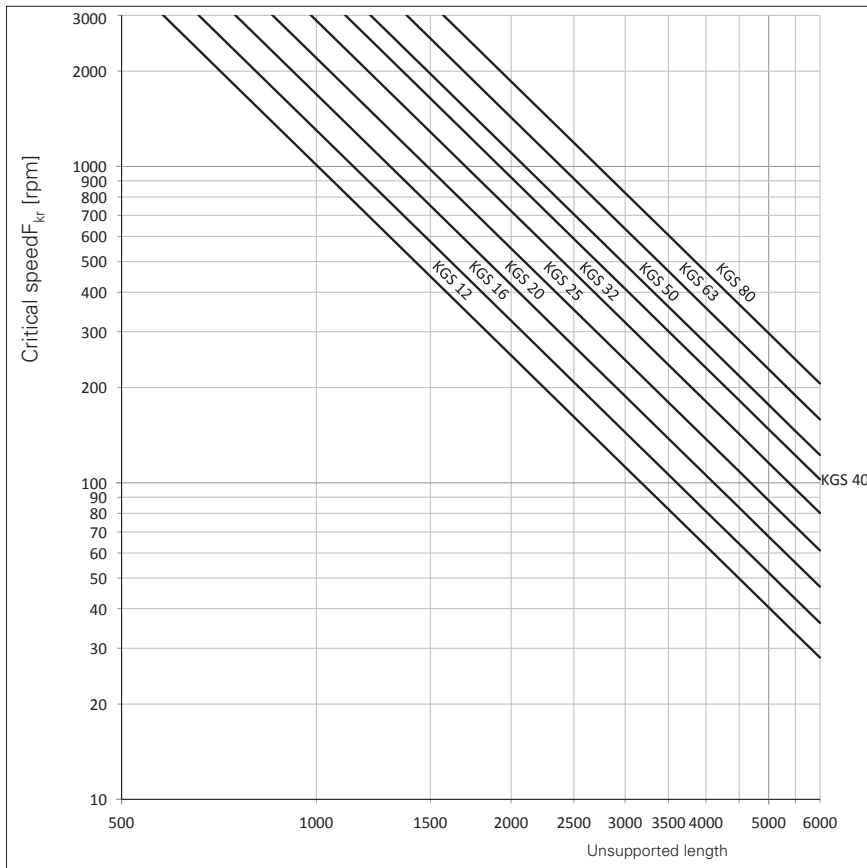

# General technical data

## Trapezoidal-threaded spindles

Trapezoidal-threaded spindles from Neff Gewindetriebe are manufactured by rolling according to DIN 103. Thanks to the non-cutting cold forming, the grain is not interrupted; the surface of the thread is compacted and burnished.

### Advantages of rolled trapezoidal-threaded spindles:

- Improved tensile strength
- Higher resistance to wear
- High dimensional accuracy
- Improved bending strength

### Areas of application:

Rolled trapezoidal-threaded spindles can be used wherever an inexpensive solution is required for the transformation of rotary motion into translatory motion, even under harsh environmental conditions.

### Precision trapezoidal-threaded spindle RPTS

	Thread	Ø	Pitch	Number of starts	Direction of rotation	Length	Material	Weldability	Accuracy	Straightness	Surface
Standard	Metric ISO trapezoidal thread according to DIN 103-7e	10-80 mm	2-24 mm	Up to 6 starts	right-handed, single-start also left-handed	3000 mm up to Tr 18x4, 6000 mm from Tr 20x6	1.0401 bright steel C15, stress-relieved glowing	very easily weldable	50-300 µm/300mm	0,1-0,5 mm/300 mm	Burnished
Stainless	Metric ISO trapezoidal thread according to DIN 103-7e (1)	18-40 mm	4-7 mm	single-start	right and left-handed	3000 mm up to Tr 20x4, 6000 mm from Tr 30x6	1.4305 X8Cr-NiS18-9, austenite and corrosion resistant bright steel	conditionally weldable	50-300 µm/300mm	0,1-0,5 mm/300 mm	Burnished
Manganese-phosphated	Metric ISO trapezoidal thread according to DIN 103-7e (1)	10-80 mm	2-24 mm	Up to 6 starts	right-handed, single-start also left-handed	3000 mm up to Tr 18x4, 6000 mm from Tr 20x6	1.0401 bright steel C15, stress-relieved glowing, weldable, manganic phosphate-treated	very easily weldable	50-300 µm/300mm	0,1-0,5 mm/300 mm	Crystalline phosphate surface

### Trapezoidal-threaded nuts

Typ	TGM-SKM	TGM-KSM	TGM-LRM	TGM-EFM	TGM-SFM	TGM-LKM
Thread	DIN 103-7H	DIN 103-7H	DIN 103-7H	DIN 103-7H	DIN 103-7H	DIN 103-7H
Nominal DM	10-70 mm	10-80 mm	10-80 mm	12-80 mm	12-80 mm	12-50 mm
Pitch	2-10 mm	2-10mm	2-10mm	3-10 mm	3-10 mm	3-8 mm
Number of threads	single-start	single-start	single or multi-start	single or multi-start	single or multi-start	single or multi-start
Thread direction	Right or left-hand thread	Right or left-hand thread	Right or left-hand thread	Right or left-hand thread	Right or left-hand thread	Right or left-hand thread
Material	1.0718 (9SMn 28K)	1.0718 (9SMn 28K)	2.1090 (G-CuSn7ZnPb)	2.1090 (G-CuSn7ZnPb)	2.1090 (G-CuSn7ZnPb)	PETP
Suitable for	Clamping processes, adjustment movements in manual operation	Clamping processes, adjustment movements in manual operation	Low and medium-speed movement drives	Movement drives with particularly favourable wear characteristics	Safety-relevant movement drives with particularly favourable wear characteristics	For low-noise movement drives with higher speed and duty cycle

# General technical data

## Trapezoidal-threaded spindles

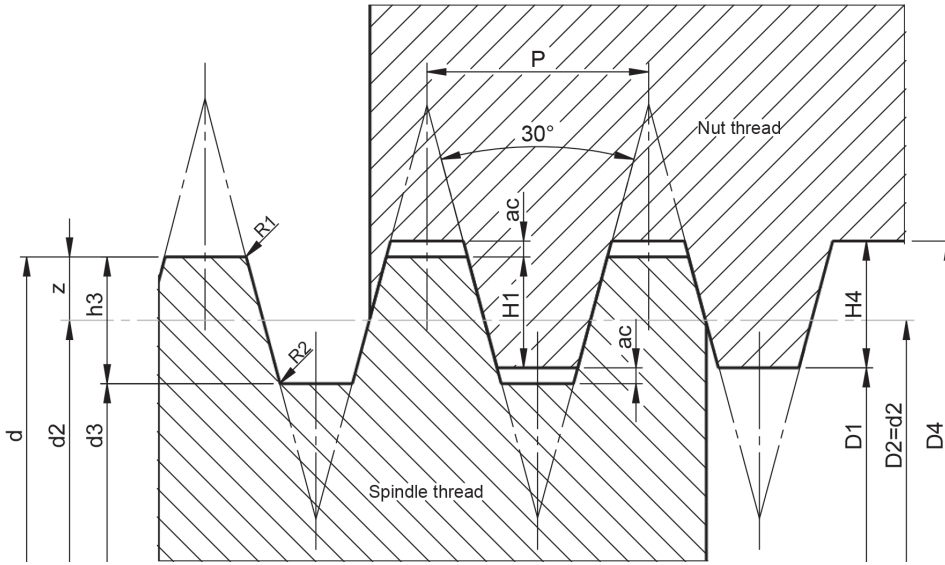

$$D_1 = d - 2H_1 = d - P$$

$$H_1 = 0.5P$$

$$H_4 = H_1 + a_c = 0.5P + a_c$$

$$h_3 = H_1 + a_c = 0.5P + a_c$$

$$z = 0.25P = H_1/2$$

$$D_4 = d + 2a_c$$

$$d_3 = d - 2h_3 \text{ (due to the rolling process max. } 0.15 \times P \text{ smaller sized)}$$

$$d_2 = D_2 = d - 2z = d - 0.5P$$

$$a_c = \text{backlash}$$

$$R_1 = \text{max. } 0.5$$

$$R_2 = \text{max. } a_c \text{ (is omitted with rolled spindles and replaced by } 0.15 \times P/2 = \text{flow radius)}$$

### Dimensions for thread profile

P	$a_c^{(1)}$	$R_{1 \text{ max.}}$	$R_{2 \text{ max.}}^{(2)}$
1.5	0.15	0.075	0.2625
2	0.25	0.125	0.4
3	0.25	0.125	0.475
4	0.25	0.125	0.55
5	0.25	0.125	0.625
6	0.5	0.25	0.95
7	0.5	0.25	1.025
8	0.5	0.25	1.1
9	0.5	0.25	1.175
10	0.5	0.25	1.25

### Profiles for multi-start threads:

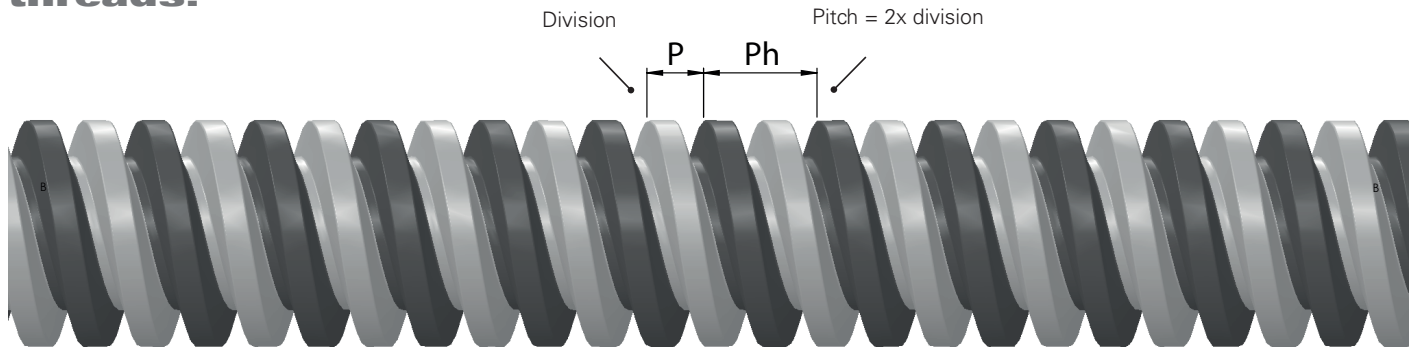

Multi-start threads have the same profile as single-start threads with the pitch  $P_h = \text{division } P$ .

$P = \text{division}$ :  
Distance along the effective pitch diameter line between neighbouring flanks in the same direction.

$P_h = \text{pitch}$ :  
Distance along the effective pitch diameter line between neighbouring flanks in the same direction of the same thread pitch.

# Trapezoidal-threaded spindles RATS

## Rolled precision trapezoidal-threaded spindle RATS made of case-hardened steel C15

Material: 1.4305 (X8CrNiS18-9)

Tolerance class: 7e

Manufacturing length: 3000mm up to  $\varnothing$  20mm, 6000mm from  $\varnothing$  20mm

Excess lengths: up to 12000 mm on enquiry

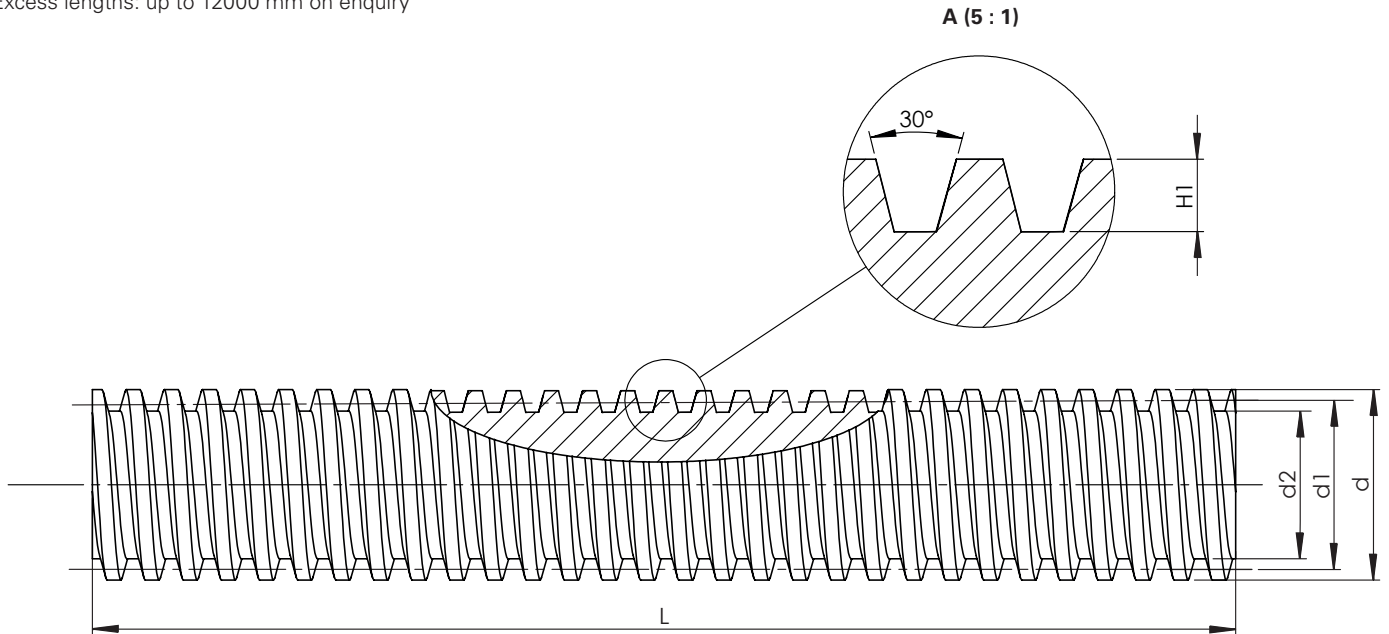

Type Outside diameter [mm] Pitch [mm] right/left-handed	d	Dimension [mm]				Accuracy [ $\mu$ /300 mm]	Straightness [mm/300 mm]	Pitch angle (2.1. 2.2. 2.3)	Efficiency <sup>(3)</sup>	Linear load [kg/m]	Geometrical moment of inertia [cm <sup>4</sup> ]	Resistive torque [cm <sup>3</sup> ]	Mass moment of inertia [kg m <sup>2</sup> /m]
		$d_{1 \min}$	$d_{1 \max}$	$d_2$	$H_1^{(1)}$			$\alpha$					
RATS Tr 18x4	18	15.640	15.905	12.80	2	50	0.1	4° 32'	0.43	1.58	0.132	0.206	$5.05 \cdot 10^{-5}$
RATS Tr 18x8 P4	18	15.640	15.905	12.80	2	50	0.2	9° 14'	0.43	1.58	0.132	0.206	$5.05 \cdot 10^{-5}$
RATS Tr 20x4	20	17.640	17.905	14.80	2	50	0.1	4° 2'	0.40	2.00	0.236	0.318	$8.10 \cdot 10^{-5}$
RATS Tr 24x5	24	21.094	21.394	17.50	2.5	50	0.1	4° 14'	0.41	2.85	0.460	0.526	$1.65 \cdot 10^{-4}$
RATS Tr 30x6	30	26.547	26.882	21.90	3	50	0.1	4° 2'	0.40	4.50	1.130	1.030	$4.10 \cdot 10^{-4}$
RATS Tr 36x6	36	32.547	32.882	27.90	3	50	0.1	3° 18'	0.35	6.71	2.970	2.130	$9.10 \cdot 10^{-4}$
RATS Tr 40x7	40	36.020	36.375	30.50	3.5	50	0.1	3° 29'	0.37	8.21	4.250	2.790	$1.37 \cdot 10^{-3}$

(1) Thread depth of the basic profile according to DIN 103

(2.1) Self-locking from the movement < 2.4°

(2.2) Self-locking from the fill level > 2.4° < 4.5°

(2.3) No self-locking > 4.5°

(3) Efficiency, calculated with friction value 0.1

# Trapezoidal screw spindles RPTS

## Rolled precision trapezoidal-threaded spindles RPTS made of case-hardened steel C15

Material: 1.0401 (C15)

Tolerance class: 7e

Manufacturing length: 3000mm up to  $\varnothing$  20mm, 6000mm from  $\varnothing$  20mm

Excess lengths: up to 12000 mm on enquiry

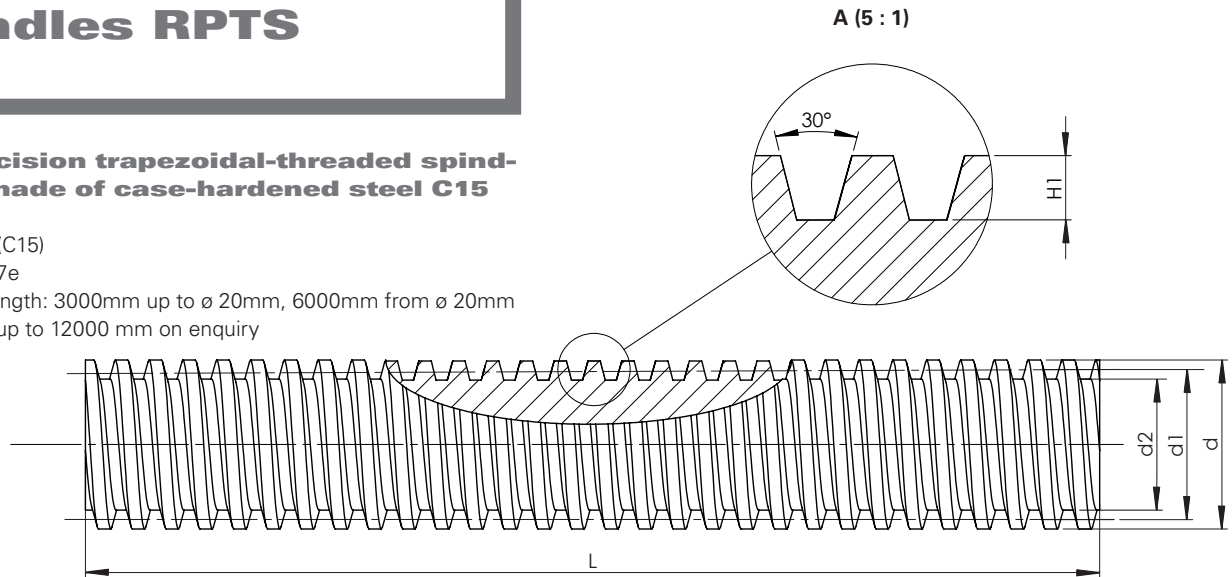

Type Outside diameter [mm] Pitch [mm] right/left-handed	d	Dimension [mm]				Accuracy [ $\mu$ m/ 300 mm]	Straight- ness [mm/ 300 mm]	Pitch angle (2.1, 2.2, 2.3) $\alpha$	Efficiency <sup>(3)</sup> $\eta$	Linear load [kg/m]	Geometrical moment of inertia [cm <sup>4</sup> ]	Resistive torque [cm <sup>3</sup> ]	Mass moment of inertia [kg m <sup>2</sup> /m]
		d <sub>1 min</sub>	d <sub>1 max</sub>	d <sub>2</sub>	H <sub>1</sub> <sup>(1)</sup>								
RPTS Tr 10x2	10	8.739	8.929	6.89	1	300	0.5	4° 2'	0.40	0.500	0.011	0.032	0.51 · 10 <sup>-5</sup>
RPTS Tr 10x3		8.191	8.415	5.84	1.5	300	0.5	6° 24'	0.51	0.446	0.0057	0.020	0.40 · 10 <sup>-5</sup>
RPTS Tr 12x3	12	10.191	10.415	7.84	1.5	300	0.5	5° 11'	0.46	0.68	0.019	0.047	0.94 · 10 <sup>-5</sup>
RPTS Tr 12x6 P3	12	10.165	10.415	7.84	1.5	300	0.5	10° 18'	0.62	0.68	0.019	0.047	0.94 · 10 <sup>-5</sup>
RPTS Tr 14x3	14	12.191	12.415	9.84	1.5	300	0.5	4° 22'	0.42	0.96	0.046	0.094	1.88 · 15 <sup>-5</sup>
RPTS Tr 14x4		11.640	11.905	8.80	2	300	0.5	6° 3'	0.50	0.888	0.029	0.067	1.60 · 10 <sup>-5</sup>
RPTS Tr 16x2	16	14.729	14.929	12.89	1	50	0.1	2° 36'	0.28	1.39	1.36	0.21	3.9 · 10 <sup>-5</sup>
RPTS Tr 16x4	16	13.640	13.905	10.80	2	50	0.1	5° 11'	0.46	1.21	0.067	0.124	2.96 · 10 <sup>-5</sup>
RPTS Tr 16x8 P4	16	13.608	13.905	10.80	2	300	0.3	10° 18'	0.62	1.21	0.067	0.124	2.96 · 10 <sup>-5</sup>
RPTS Tr 18x4	18	15.640	15.905	12.80	2	50	0.1	4° 32'	0.43	1.58	0.132	0.206	5.05 · 10 <sup>-5</sup>
RPTS Tr 18x8 P4	18	15.640	15.905	12.80	2	50	0.2	9° 14'	0.43	1.58	0.132	0.206	5.05 · 10 <sup>-5</sup>
RPTS Tr 20x4	20	17.640	17.905	14.80	2	50	0.1	4° 2'	0.40	2.00	0.236	0.318	8.10 · 10 <sup>-5</sup>
RPTS Tr 20x8 P4		17.608	17.905	14.80	2	200	0.2	8° 3'	0.57	2.00	0.236	0.318	8.10 · 10 <sup>-5</sup>
RPTS Tr 20x16 P4		17.608	17.905	14.80	2	200	0.2	15° 47'	0.71	2.00	0.236	0.318	8.10 · 10 <sup>-5</sup>
RPTS Tr 22x5	22	19.114	19.394	15.50	2.5	50	0.1	4° 39'	0.43	2.34	0.283	0.366	1.11 · 10 <sup>-4</sup>
RPTS Tr 22x24 P4 S		19.140	19.505	16.50	2.5	200	0.2	21° 34'	0.75	2.34	0.364	0.441	1.11 · 10 <sup>-4</sup>
RPTS Tr 24x5	24	21.094	21.394	17.50	2.5	50	0.1	4° 14'	0.41	2.85	0.460	0.526	1.65 · 10 <sup>-4</sup>
RPTS Tr 24x10 P5		21.058	21.394	17.50	2.5	200	0.2	8° 25'	0.58	2.85	0.460	0.526	1.65 · 10 <sup>-4</sup>
RPTS Tr 26x5	26	23.094	23.394	19.50	2.5	50	0.1	3° 52'	0.39	3.40	0.710	0.728	2.35 · 10 <sup>-4</sup>
RPTS Tr 28x5	28	25.094	25.394	21.50	2.5	50	0.1	3° 34'	0.37	4.01	1.050	0.976	3.26 · 10 <sup>-4</sup>
RPTS Tr 30x6	30	26.547	26.882	21.90	3	50	0.1	4° 2'	0.40	4.50	1.130	1.030	4.10 · 10 <sup>-4</sup>
RPTS Tr 30x12 P6		26.507	26.882	21.90	3	200	0.2	8° 3'	0.57	4.50	1.130	1.030	4.10 · 10 <sup>-4</sup>
RPTS Tr 32x6	32	28.547	28.882	23.90	3	50	0.1	3° 46'	0.38	5.19	1.600	1.340	5.45 · 10 <sup>-4</sup>
RPTS Tr 36x6	36	32.547	32.882	27.90	3	50	0.1	3° 18'	0.35	6.71	2.970	2.130	9.10 · 10 <sup>-4</sup>
RPTS Tr 36x12 P6	36	32.547	32.882	27.90	3	50	0.1	6° 41'	0.35	6.71	2.970	2.130	9.10 · 10 <sup>-4</sup>
RPTS Tr 40x7	40	36.020	36.375	30.50	3.5	50	0.1	3° 29'	0.37	8.21	4.250	2.790	1.37 · 10 <sup>-3</sup>
RPTS Tr 40x14 P7		35.978	36.375	30.50	3.5	200	0.2	6° 57'	0.53	8.21	4.250	2.790	1.37 · 10 <sup>-3</sup>
RPTS Tr 44x7	44	40.020	40.275	34.50	3.5	50	0.1	3° 8'	0.34	10.10	6.950	4.030	2.10 · 10 <sup>-3</sup>
RPTS Tr 48x8	48	43.468	43.868	37.80	4	100	0.1	3° 18'	0.35	12.00	10.000	5.300	2.90 · 10 <sup>-3</sup>
RPTS Tr 50x8	50	45.468	45.868	39.30	4	100	0.1	3° 10'	0.34	13.10	11.700	5.960	3.40 · 10 <sup>-3</sup>
RPTS Tr 55x9	55	50.500	51.060	43.60	4.5	100	0.2	3° 14'	0.33	15.40	17.740	8.140	5.01 · 10 <sup>-4</sup>
RPTS Tr 60x9	60	54.935	55.360	48.15	4.5	200	0.3	2° 57'	0.33	19.00	26.400	11.000	7.30 · 10 <sup>-3</sup>
RPTS Tr 70x10	70	64.425	64.850	57.00	5	200	0.3	2° 48'	0.32	26.00	51.800	18.200	1.40 · 10 <sup>-2</sup>
RPTS Tr 80x10	80	74.425	74.850	67.00	5	200	0.3	2° 25'	0.29	34.70	98.900	29.500	2.40 · 10 <sup>-2</sup>

(1) Thread depth of the basic profile according to DIN 103  
(2.1) Self-locking from the movement < 2.4°

(2.2) Self-locking from the fill level > 2.4° < 4.5°  
(2.3) No self-locking > 4.5°

(3) Efficiency, calculated with friction value 0.1



## Ordering code trapezoidal screw spindle

### Ordering code for trapezoidal screw spindle

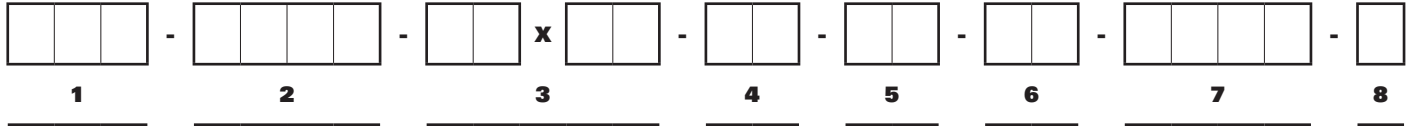

No.	Designation	Code	Description	
<b>1</b>	Product abbreviation	<b>TGS</b>		
<b>2</b>	Spindle abbreviation	<b>RPTS</b>	rolled precision trapezoidal-threaded spindle	
		<b>WPTS</b>	spun precision trapezoidal-threaded spindle	
		<b>RATS</b>	rolled precision A2 trapezoidal-threaded spindle	
		<b>WATS</b>	spun precision A2 trapezoidal-threaded spindle	
<b>3</b>	Thread designation		e.g. 20x4 (diameter 20 mm, pitch 4 mm)	
<b>4</b>	Pitch direction	<b>RH</b>	Right-hand thread	
		<b>LH</b>	Left-hand thread	
<b>5</b>	Spindle end A	<b>O</b> End only sawn and brushed <b>A</b> End with chamfer <b>K</b> End according to customer drawing or project drawing no. <b>D</b> End fixed bearing form D for bearing ZKLF <b>F</b> End fixed bearing form F for bearing ZARN <b>H</b> End fixed bearing form H for bearing ZARF/LTN <b>J</b> End fixed bearing form J for bearing FDX 12-40 <b>L</b> End fixed bearing form L for bearing 7201-7208 <b>S</b> End movable bearing form S for bearing 6001-6211 <b>T</b> End movable bearing form T for needle bearing HK1614-4518 <b>W</b> End movable bearing form W for bearing 6001-6211 <b>Fk</b> End fixed bearing unit FK4-FK30 <b>FF</b> End movable bearing unit FF6-FF30 <b>BK</b> End fixed bearing unit BK10-BK40 <b>BF</b> End movable bearing unit BF10-BF40 <b>M</b> Metric threaded stem SHG <b>AS</b> End hollowing safeguard SHG <b>RS</b> End worm gear connection rotary spindle SHG <b>VS</b> End anti-twist device SHG <b>Z</b> cylindrical bearing journal SHG with rotary spindle		
<b>6</b>	Spindle end B			
<b>7</b>	Overall length in (mm)			e.g. 1000
<b>8</b>	Special requirements		<b>0</b>	none
			<b>1</b>	According to specification, description or drawing

# Trapezoidal- threaded nut TGM

## Short steel nut blank, cylindrical KSM

Suitable for clamping processes, adjustment movements in manual operation and as a fastening nut. Not suitable for movement drives, since the tribological pairing steel-steel tends towards scuffing.

Further processing: The thread serves as the reference for accurate machining and mounting.

Material: Free-cutting steel 1.0718 (9 SMn 28K)

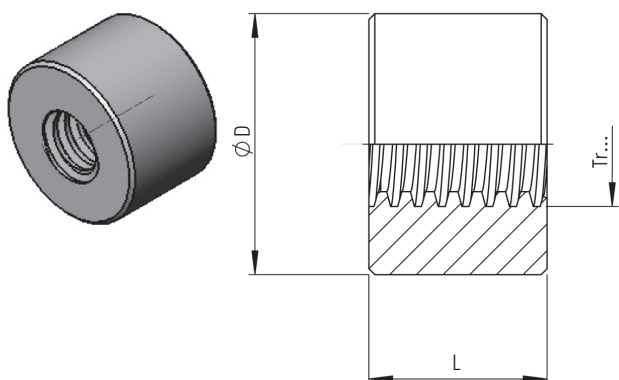

Type	D [mm]	L [mm]	Mass [kg]
KSM Tr 10x2	22	15	0.037
KSM Tr 10x3	22	15	0.036
KSM Tr 12x3	26	18	0.064
KSM Tr 14x3	30	21	0.96
KSM Tr 14x4	30	21	0.96
KSM Tr 16x4	36	24	0.16
KSM Tr 18x4	40	27	0.22
KSM Tr 20x4	45	30	0.31
KSM Tr 22x5	45	33	0.33
KSM Tr 24x5	50	36	0.45
KSM Tr 26x5	50	39	0.47
KSM Tr 28x5	60	42	0.76
KSM Tr 30x6	60	45	0.79
KSM Tr 32x6	60	48	0.81
KSM Tr 36x6	75	54	1.5
KSM Tr 40x7	80	60	1.9
KSM Tr 44x7	80	66	2.7
KSM Tr 48x8	90	72	2.9
KSM Tr 50x8	90	75	2.7
KSM Tr 60x9	100	90	3.7
KSM Tr 70x10	110	105	4.9
KSM Tr 80x10	120	120	6.4

## Hexagonal steel nut SKM

Suitable for clamping processes, adjustment movements in manual operation and as a fastening nut. Not suitable for movement drives, since the tribological pairing steel-steel tends towards scuffing.

Further processing: The thread serves as the reference for accurate machining and mounting.

Material: Free-cutting steel 1.0718 (9 SMn 28K)

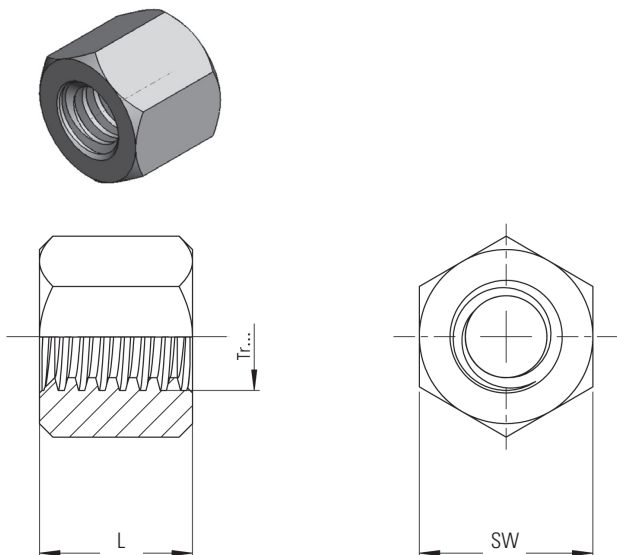

Type	SW [mm]	L [mm]	Mass [kg]
SKM Tr 10x2	17	15	0.022
SKM Tr 10x3	17	15	0.022
SKM Tr 12x3	19	18	0.028
SKM Tr 14x3	22	21	0.044
SKM Tr 14x4	22	21	0.044
SKM Tr 16x4	27	24	0.084
SKM Tr 18x4	27	27	0.086
SKM Tr 20x4	30	30	0.17
SKM Tr 22x5	30	33	0.17
SKM Tr 24x5	36	36	0.20
SKM Tr 26x5	36	39	0.20
SKM Tr 28x5	41	42	0.30
SKM Tr 30x6	46	45	0.43
SKM Tr 32x6	46	48	0.42
SKM Tr 36x6	55	54	0.73
SKM Tr 40x7	65	60	1.3
SKM Tr 44x7	65	66	1.2
SKM Tr 48x8	75	72	1.8
SKM Tr 50x8	75	75	1.8
SKM Tr 60x9	90	90	2.8
SKM Tr 70x10	90	105	3.1

# Trapezoidal- threaded nut TGM

Type	D [mm]	L [mm]	Mass [kg]	Bearing percentage [mm <sup>2</sup> ]
LRM Tr 10x2	22	20	0.056	200
LRM Tr 10x3	22	20	0.056	190
LRM Tr 12x3	26	24	0.092	280
LRM Tr 12x6 P3	26	24	0.092	280
LRM Tr 14x3	30	28	0.14	380
LRM Tr 14x4	30	28	0.14	370
LRM Tr 16x2	36	32	0.25	490
LRM Tr 16x4	36	32	0.25	490
LRM Tr 16x8 P4	36	32	0.25	490
LRM Tr 18x4	40	36	0.34	630
LRM Tr 18x8 P4	40	36	0.34	630
LRM Tr 20x4	45	40	0.48	790
LRM Tr 20x8 P4	45	40	0.45	790
LRM Tr 20x16 P4	45	40	0.45	790
LRM Tr 22x5	45	40	0.46	850
LRM Tr 22x24 P4S	45	40	0.46	880
LRM Tr 24x5	50	48	0.69	1130
LRM Tr 24x10 P5	50	48	0.65	1130
LRM Tr 26x5	50	48	0.58	1240
LRM Tr 28x5	60	60	1.2	1680
LRM Tr 30x6	60	60	1.2	1780
LRM Tr 30x12 P6	60	60	1.2	1780
LRM Tr 32x6	60	60	1.2	1910
LRM Tr 36x6	75	72	2.2	2610
LRM Tr 36x12 P6	75	72	2.2	2610
LRM Tr 40x7	80	80	2.8	3210
LRM Tr 40x14 P7	80	80	2.8	3210
LRM Tr 44x7	80	80	2.6	3560
LRM Tr 48x8	90	100	4.3	4840
LRM Tr 50x8	90	100	4.2	5060
LRM Tr 60x9	100	120	5.7	7320
LRM Tr 70x10	110	140	7.6	10000
LRM Tr 80x10	120	160	9.7	13200

## Long red brass nut, cylindrical LRM

For movement drives with particularly favourable wear characteristics. Suitable for use as a lock nut.

Further processing: The thread serves as the reference for accurate machining and mounting.

Material: 2.1090 (G-CuSn 7Zn Pb (Rg7))

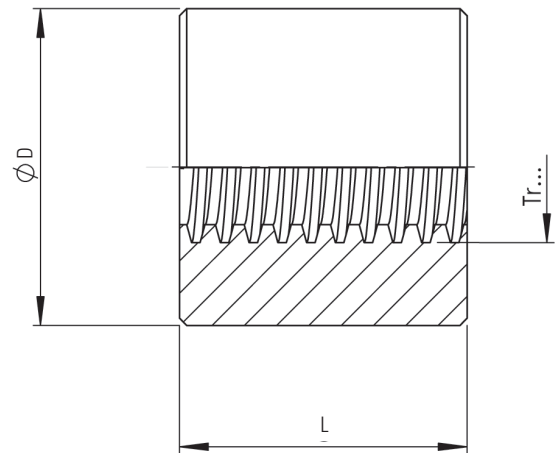
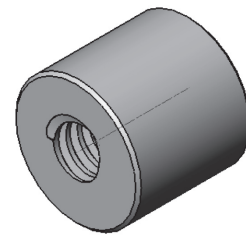

# Trapezoidal- threaded nut TGM

## Ready-to-install bronze nut EFM

For movement drives with particularly favourable wear characteristics.

Suitable for use as a lock nut.

EFMs can be mounted using the KON and KAR adaptors.

Material: 2.1090 (G-CuSn 7Zn Pb (Rg7))

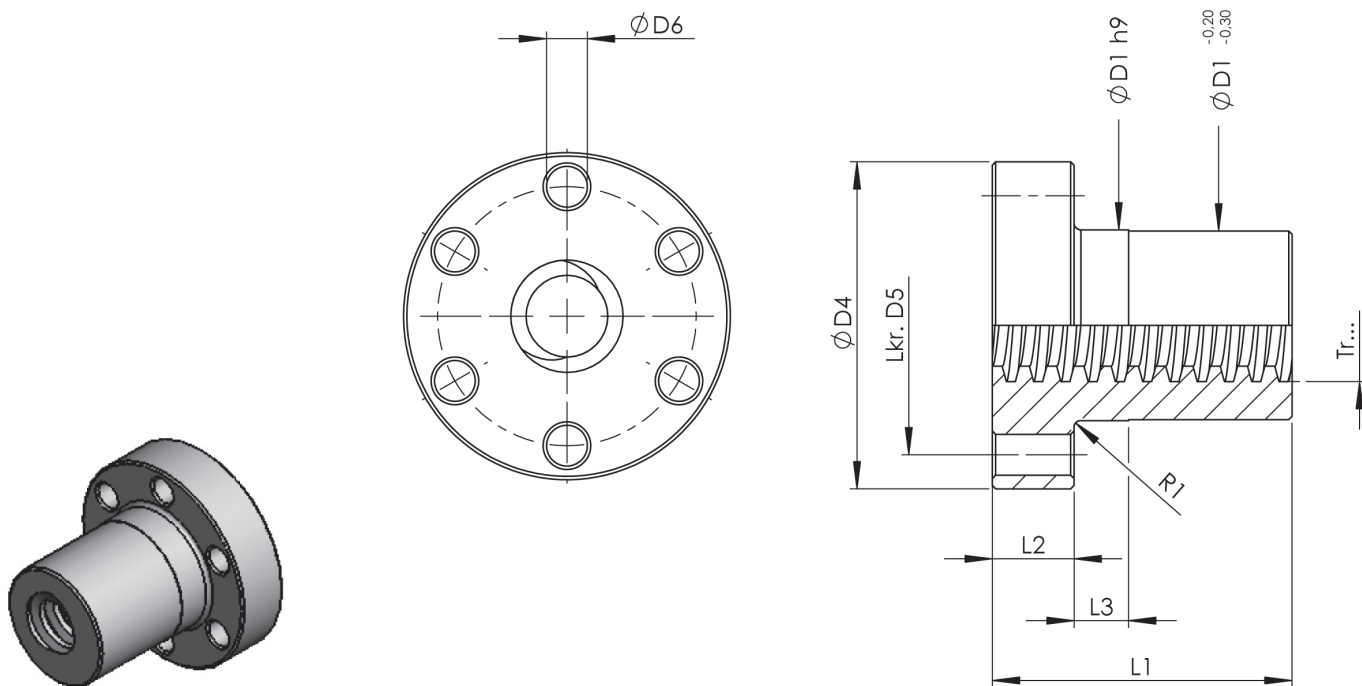

Type	Dimensions [mm]							Mass [kg]	Bearing percentage [mm <sup>2</sup> ]
	D <sub>1</sub>	D <sub>4</sub>	D <sub>5</sub>	6xD <sub>6</sub>	L <sub>1</sub>	L <sub>2</sub>	L <sub>3</sub>		
EFM Tr 12x3	24	40	32	6	28	12	10	0.11	520
EFM Tr 12x6 P3	24	40	32	6	28	12	10	0.11	520
EFM Tr 16x4	28	48	38	6	44	12	8	0.25	670
EFM Tr 16x8 P4	28	48	38	6	44	12	8	0.25	670
EFM Tr 18x4	28	48	38	6	44	12	8	0.25	770
EFM Tr 18x8 P4	28	48	38	6	44	12	8	0.25	770
EFM Tr 20x4	32	55	45	7	44	12	8	0.30	870
EFM Tr 20x8 P4	32	55	45	7	44	12	8	0.30	870
EFM Tr 20x16 P4	32	55	45	7	44	12	8	0.30	870
EFM Tr 24x5	32	55	45	7	44	12	8	0.30	1040
EFM Tr 24x10 P5	32	55	45	7	44	12	8	0.30	1040
EFM Tr 30x6	38	62	50	7	46	14	8	0.40	1370
EFM Tr 30x12 P5	38	62	50	7	46	14	8	0.40	1370
EFM Tr 36x6	45	70	58	7	59	16	10	0.60	2140
EFM Tr 36x12 P5	45	70	58	7	59	16	10	0.60	2140
EFM Tr 40x7	63	95	78	9	73	16	10	1.70	2930
EFM Tr 40x14 P7	63	95	78	9	73	16	10	1.70	2930
EFM Tr 50x8	72	110	90	11	97	18	10	2.60	4900
EFM Tr 60x9	85	125	105	11	99	20	10	3.70	6040
EFM Tr 70x10	95	180	140	17	100	30	16	7.80	8250
EFM Tr 80x10	105	190	150	17	110	30	16	8.90	10890

# Trapezoidal- threaded nut TGM

## Safety trap nut SFM

Safety trap nuts are used wherever increased operational reliability is demanded and in order to limit the economic damages in case of a nut breakage.

Safety trap nuts for VBG 14 or VBG 70 requirements on enquiry.

The safety trap nut runs along with the travelling nut without axial load and thus wear-free. As wear of the travelling nut increases, the distance X between the two nuts decreases.

The travelling nut must be replaced when the distance X is reduced by 25%.

If the thread turns of, the travelling nut should break through due to excessive wear, the safety trap nut absorbs the applied load.

The safety trap nut can only be ordered in conjunction with the flange nut.

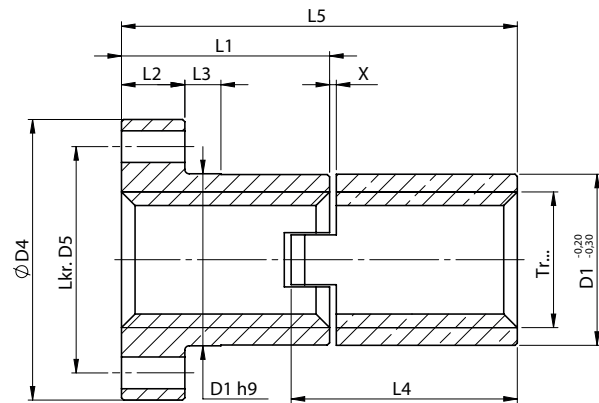
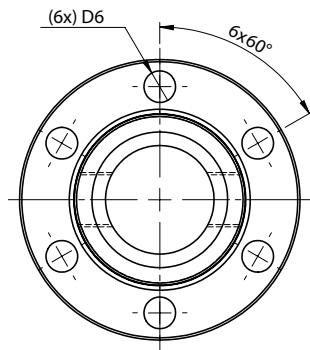
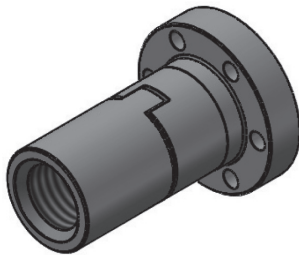

Type	D <sub>1</sub> [mm]	D <sub>4</sub> [mm]	D <sub>5</sub> [mm]	6xD <sub>6</sub> [mm]	L <sub>1</sub> [mm]	L <sub>2</sub> [mm]	L <sub>3</sub> [mm]	L <sub>4</sub> [mm]	L <sub>5</sub> [mm]	X [mm]	mass [kg]	Bearing percentage [mm <sup>2</sup> ]
EFM-SFM Tr 12x3	24	40	32	6	28	12	10	24	48	4	0.2	520
EFM-SFM Tr 12x6 P3	24	40	32	6	28	12	10	24	48	4	0.2	520
EFM-SFM Tr 16x4	28	48	38	6	44	12	8	32	72	4	0.5	670
EFM-SFM Tr 16x8 P4	28	48	38	6	44	12	8	32	72	4	0.5	670
EFM-SFM Tr 18x4	28	48	38	6	44	12	8	36	76	4	0.59	770
EFM-SFM Tr 20x4	32	55	45	7	44	12	8	40	80	4	0.75	870
EFM-SFM Tr 20x8 P4	32	55	45	7	44	12	8	40	80	4	0.75	870
EFM-SFM Tr 20x16 P4	32	55	45	7	44	12	8	40	80	4	0.75	870
EFM-SFM Tr 24x5	32	55	45	7	44	12	8	48	88	4	0.95	1040
EFM-SFM Tr 24x10 P5	32	55	45	7	44	12	8	48	88	4	0.95	1040
EFM-SFM Tr 30x6	38	62	50	7	46	14	8	60	102	4	1.6	1370
EFM-SFM Tr 30x12 P6	38	62	50	7	46	14	8	60	102	4	1.6	1370
EFM-SFM Tr 36x6	45	70	58	7	59	16	10	72	127	4	2.8	2140
EFM-SFM Tr 36x12 P6	45	70	58	7	59	16	10	72	127	4	2.8	2140
EFM-SFM Tr 40x7	63	95	78	9	73	16	10	80	149	4	4.5	2930
EFM-SFM Tr 40x14 P7	63	95	78	9	73	16	10	80	149	4	4.5	2930
EFM-SFM Tr 50x8	72	110	90	11	97	18	10	100	193	4	6.8	4900
EFM-SFM Tr 60x9	85	125	105	11	99	20	10	120	215	8	9.4	6040
EFM-SFM Tr 70x10	95	180	140	17	100	30	16	140	236	8	15.4	8250
EFM-SFM Tr 80x10	105	190	150	17	110	30	16	160	266	8	18.6	10890

# Trapezoidal- threaded nut TGM

## Long plastic nut blank, cylindrical LKM

For low-noise movement drives with higher speed and higher duty cycle too. Particularly recommend for use with rolled trapezoidal spindles. Good emergency running characteristics.

Material: PETP

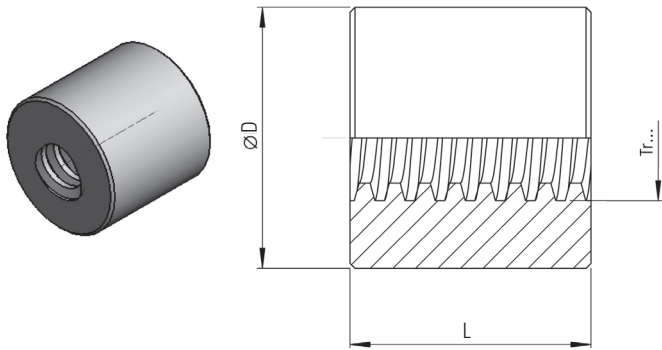

Type	D [mm]	L [mm]	Mass [kg]	Bearing percentage [mm <sup>2</sup> ]
LKM Tr 12x3	26	24	0.012	280
LKM Tr 12x6 P3	26	24	0.012	280
LKM Tr 16x4	36	32	0.032	490
LKM Tr 16x8 P4	36	32	0.032	490
LKM Tr 20x4	45	40	0.06	790
LKM Tr 20x8 P4	45	40	0.06	790
LKM Tr 24x5	50	48	0.088	1130
LKM Tr 24x10 P5	50	48	0.088	1130
LKM Tr 30x6	60	60	0.15	1780
LKM Tr 30x12 P6	60	60	0.15	1780
LKM Tr 36x6	75	72	0.30	2610
LKM Tr 36x12 P6	75	72	0.30	2610
LKM Tr 40x7	80	80	0.37	3210
LKM Tr 40x14 P7	80	80	0.37	3210
LKM Tr 50x8	90	100	0.55	5060

## Ordering code for trapezoidal-threaded nuts

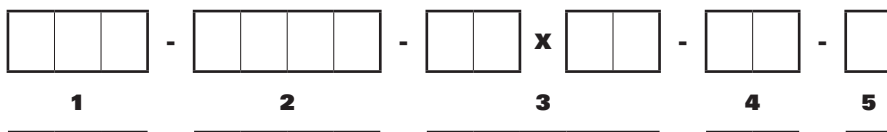

No.	Designation	Code	Description
1	Product abbreviation	<b>TGM</b>	
2	Spindle abbreviation	<b>KSM</b>	Short steel nut blank, cylindrical
		<b>SKM</b>	Hexagonal steel nut
		<b>LRM</b>	Long red brass nut
		<b>EFM</b>	Ready-to-install bronze nut
		<b>LKM</b>	Long plastic nut, cylindrical
		<b>SFMM</b>	Safety trap nut (located on flange side)
3	Thread designation		e.g. 20x4 (diameter 20 mm, pitch 4 mm)
4	Pitch direction	<b>RH</b>	Right-hand thread
		<b>LH</b>	Left-hand thread
5	Special requirements	<b>0</b>	None
		<b>1</b>	According to specification, description or drawing

# Ordering code

## trapezoidal screw drive

### Ordering code for trapezoidal screw drive

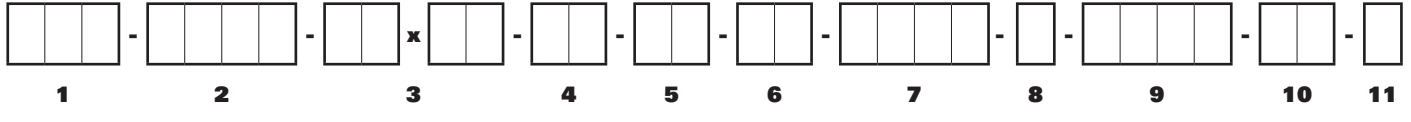

No.	Designation	Code	Description	
<b>1</b>	Product abbreviation	<b>TGS</b>		
<b>2</b>	Spindle abbreviation	<b>RPTS</b>	rolled precision trapezoidal-threaded spindle	
		<b>WPTS</b>	spun precision trapezoidal-threaded spindle	
		<b>RATS</b>	rolled precision A2 trapezoidal-threaded spindle	
		<b>WATS</b>	spun precision A2 trapezoidal-threaded spindle	
<b>3</b>	Thread designation		e.g. 20x4 (diameter 20 mm, pitch 4 mm)	
<b>4</b>	Pitch direction	<b>RH</b>	Right-hand thread	
		<b>LH</b>	Left-hand thread	
<b>5</b>	Spindle end A	<b>O</b> Ends only sawn and brushed <b>A</b> End with chamfer <b>K</b> End according to customer drawing or project drawing no. <b>D</b> End fixed bearing form D for bearing ZKLF <b>F</b> End fixed bearing form F for bearing ZARN <b>H</b> End fixed bearing form H for bearing ZARF/LTN <b>J</b> End fixed bearing form J for bearing FDX 12-40 <b>L</b> End fixed bearing form L for bearing 7201-7208 <b>S</b> End movable bearing form S for bearing 6001-6211 <b>T</b> End movable bearing form T for needle bearing HK1614-4518 <b>W</b> End movable bearing form W for bearing 6001-6211 <b>Fk</b> End fixed bearing unit FK4-FK30 <b>FF</b> End movable bearing unit FF6-FF30 <b>BK</b> End fixed bearing unit BK10-BK40 <b>BF</b> End movable bearing unit BF10-BF40 <b>M</b> Metric threaded stem SHG <b>AS</b> End hollowing safeguard SHG <b>RS</b> End worm gear connection rotary spindle SHG <b>VS</b> End anti-twist device SHG <b>Z</b> cylindrical bearing journal SHG with rotary spindle		
<b>6</b>	Spindle end B			
<b>7</b>	Overall length in (mm)			e.g. 1000
<b>8</b>	Special requirements spindle		<b>0</b>	none
			<b>1</b>	According to specification, description or drawing
<b>9</b>	Trapezoidal-threaded nut or nut unit with installation note		<b>KSM</b>	Short steel nut blank, cylindrical
			<b>SKM</b>	Hexagonal steel nut
			<b>LRM</b>	Long red brass nut
			<b>EFM</b>	Ready-to-install bronze nut
			<b>LKM</b>	Long plastic nut, cylindrical
			<b>SFMF</b>	Safety trap nut (safety trap nut located on flange side)
<b>10</b>			<b>0</b>	With cylindrical nut
			<b>F0</b>	Flange to fixed bearing (or longer spindle end)
		<b>OF</b>	Flange to movable bearing (or shorter spindle end)	
<b>11</b>	Special requirements nut	<b>0</b>	none	
		<b>1</b>	According to specification, description or drawing	

# Calculation

## trapezoidal screw drive

### Calculation of trapezoidal screw drive

Calculations / Values Page Note	Page	Note
Required bearing surface $A_{\text{erf}}$	P. 34	Comparison with bearing surface in nut tables
Feeding speed $s$	P. 34	-
Drive torque $M_{\text{ta}}$	P. 37	-
Friction coefficient $\mu_m$	P. 37	See also value table for friction coefficient
Efficiency $\eta$	P. 37	-
Friction angle $\rho'$	P. 37	-
Pitch angle $\alpha$	P. 37	See also spindle value table
Drive power $P_a$	P. 33	-
Critical speed $n_{\text{kr}}$	P. 35/36	-
Permissible operating speed $n_{\text{zul}}$	P. 35	-
Max. permissible axial spindle load $F_k$	P. 35/36	-
Permissible axial spindle load $K_{\text{zul}}$	P. 35	-
Sagging of the spindle due to dead weight $f_{\text{max}}$	-	-
Required holding torque $m_d$	P. 37	-

### Trapezoidal screw drive values

Values	Page	Note
Material characteristic values	P. 33	Data for the materials used
pv values	P. 34	for determining the max. permissible sliding speed
Friction value	P. 34	for determining the efficiency
Bearing surface $\text{mm}^2$	P. 26-30	for determining the max. axial force/max surface pressure
Thread depth of basic profile	P. 23/24	for determining the bearing surface
Accuracy	P. 23/24	Specification of the pitch deviation over 300 mm
Straightness	P. 23/24	Specification of the straightness over 300 mm
Pitch	P. 23/24	Distance travelled due to one revolution of the spindle/nut
Pitch angle	P. 23/24	for determining the self-locking/efficiency
Efficiency with friction coefficient $\mu 0.1$	P. 23/24	for other friction values see equation for efficiency and friction coefficients
Linear load	-	for determining the max. sagging of the spindle
Bearing surface	P. 34	Bearing surface of the thread
Geometrical moment of inertia	P. 23/24	for determining the max. sagging of the spindle
Resistive torque	P. 23/24	Drive design
Mass moment of inertia	P. 23/24	Drive design



# Calculation

## trapezoidal screw drive

### Material characteristic values

Material	G-CuSn7ZnPb	G-CuSn12ZnPb	9 SMn 28K	PETP
Min. tensile strength	260 N/mm <sup>2</sup>	300 N/mm <sup>2</sup>	460 N/mm <sup>2</sup>	80 N/mm <sup>2</sup>
0.2% yield strength RP 0.2	120 N/mm <sup>2</sup>	180 N/mm <sup>2</sup>	375 N/mm <sup>2</sup>	-
Min. elongation at rupture	12%	8%	8%	-
Brinell hardness HB 10/1000	70	95	159	-
Density	8.8 kg/dm <sup>3</sup>	8.71 kg/dm <sup>3</sup>	8 kg/dm <sup>3</sup>	1.38 kg/dm <sup>3</sup>
Elastic module	101000 N/mm <sup>2</sup>	100000 N/mm <sup>2</sup>	200000 N/mm <sup>2</sup>	2800-300 N/mm <sup>2</sup>
ph value	300 N/mm <sup>2</sup> * m/min	400 N/mm <sup>2</sup> * m/min	-	100 N/mm <sup>2</sup> * m/min
Impact strength	-	-	-	40 kJm <sup>2</sup>
Notch impact strength	-	-	-	4 kJm <sup>2</sup>
Thermal expansion	1.75 * 10-5 /°C	1.75 * 10-5 /°C	1.19 * 10-5 /°C	8.5 * 10-5 /°C
Water absorption	-	-	-	0.25%
Water saturation	-	-	-	0.60%
Friction against steel	-	-	-	0.05-0.08
Ball indentation hardness H 358/30	-	-	-	150 N/mm <sup>2</sup>
Elongation at yield tension 80 N/mm <sup>2</sup>	-	-	-	4-5%
max. surface pressure	< 15 N/mm <sup>2</sup>	< 15 N/mm <sup>2</sup>	< 15 N/mm <sup>2</sup>	10 N/mm <sup>2</sup>
max. sliding speed	-	-	-	120 m/min

### Drive power

$$P_a = \frac{M_d \cdot n}{9550}$$

$M_d$  Required drive torque [Nm]  
 $n$  Spindle speed [1/min]  
 $P_a$  Required drive power [kW]

# Calculation

## trapezoidal screw drive

### Load ratings of trapezoidal screw drives

As a general principle, the load rating of trapezoidal screw drives is dependent on their material, surface quality, state of wear, surface pressure, lubrication conditions, running speed and temperature, and thus on the duty cycle and the provision for heat dissipation.

The permissible surface pressure is primarily dependent on the running speed of the screw drive.

With motion drives the surface pressure should not exceed 5 N per mm<sup>2</sup>.

The permissible speed can be calculated from the respective bearing surface of the nut and the pv value of the respective nut material.

$A_{\text{erf}}$  Required bearing surface [mm<sup>2</sup>]  
 $F_{\text{ax}}$  Total axial load [N]  
 $P_{\text{zul}}$  Maximum permissible surface pressure = 5 N/mm<sup>2</sup>

pv-factors See table  
 $v_{\text{Gzul}}$  Maximum linear running speed [m/min]

$D$  Flank diameter [mm]  
 $n_{\text{zul}}$  Maximum permissible speed of rotation [1/min]

$P$  Thread pitch [mm]  
 $s_{\text{zul}}$  Permissible feeding speed [m/min]

**Required:** What travel speed is still permissible at this load?

Thread pitch  $P = 6 \text{ mm}$   
 Flank-Ø  $D = d - \frac{P}{2}$   
 $= 36 - \frac{6}{2} \text{ [mm]}$   
 $= 33 \text{ mm}$

With pv value for Rg 7 = 300 m/min

pv-factors Material	pv-factors [N/mm <sup>2</sup> · m/min]
G-CuSn 7 ZnPb (Rg 7)	300
G-CuSn 12 (G Bz 12)	400
Plastic (PETP)	100
Cast iron GG 22/GG 25	200

### Required bearing surface

**(VIII)** 
$$A_{\text{erf}} = \frac{F_{\text{ax}}}{P_{\text{zul}}}$$

### Maximum linear running speed

**(IX)** 
$$v_{\text{Gzul}} = \frac{\text{pv-value}}{P_{\text{zul}}}$$

### Maximum permissible speed of rotation

**(X)** 
$$n_{\text{zul}} = \frac{v_{\text{Gzul}} \cdot 1000}{D \cdot \pi}$$

### Permissible feeding speed

**(XI)** 
$$s_{\text{zul}} = \frac{n_{\text{zul}} \cdot P}{1000}$$

### Example load rating calculation

**Given:** Screw drive,  
 Trapezoidal-threaded spindle with bronze nut  $P_{\text{zul}} = 5 \text{ N/mm}^2$ ,  
 Total axial load  $F_{\text{ax}} = 10000 \text{ N}$

### Required bearing surface $A_{\text{erf}}$

**from (VIII)** 
$$A_{\text{erf}} = \frac{F_{\text{ax}}}{P_{\text{zul}}} = \frac{10000 \text{ N}}{5 \text{ N/mm}^2} = 2000 \text{ mm}^2$$

### Selection of the bronze nut from the technical data

36 x 6 with bearing surface  $A = 2.140 \text{ mm}^2$

### Maximum permissible running speed $v_{\text{Gzul}}$

**from (IX)** 
$$v_{\text{Gzul}} = \frac{\text{pv-value}}{P_{\text{zul}}} = \frac{300 \text{ N/mm}^2 \cdot \text{m/min}}{5 \text{ N/mm}^2} = 60 \text{ m/min}$$

### Maximum permissible speed of rotation

**from (X)** 
$$n_{\text{zul}} = \frac{v_{\text{Gzul}} \cdot 1000}{D \cdot \pi} = \frac{60 \text{ m/min} \cdot 1000 \text{ mm/m}}{33 \text{ mm} \cdot \pi} = 579 \text{ 1/min}$$

### Permissible feeding speed

**from (XI)** 
$$s_{\text{zul}} = \frac{n_{\text{zul}} \cdot P}{1000} = \frac{579 \text{ 1/min} \cdot 6 \text{ mm}}{1000 \text{ mm/m}} = 3,474 \text{ m/min}$$

**Result:** At a load of 10.000 N, the trapezoidal screw drive can be operated at a speed of 3.474 metres per min.

# Calculation

## trapezoidal screw drive

### Types of bearing

Typical values for the correction factor  $f_k$  according to the classic installation cases for standard spindle bearings.

### Neff bearing case I

Fixed bearing – loose end, correction factor  $f_k=0,25 / f_{kr}=0,43$

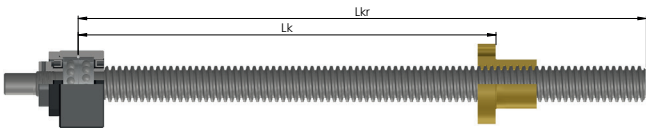

### Neff bearing case II

Movable bearing – movable bearing, correction factor  $f_k=1 / f_{kr}=1,21$

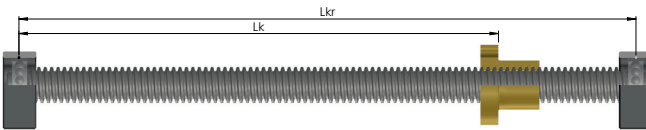

### Neff bearing case III

Fixed bearing – movable bearing, correction factor  $f_k=2,05 / f_{kr}=1,89$

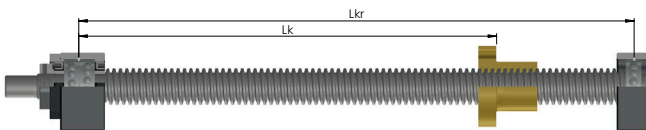

### Neff bearing case IV

Fixed bearing – fixed bearing, correction factor  $f_k=4 / f_{kr}=2,74$

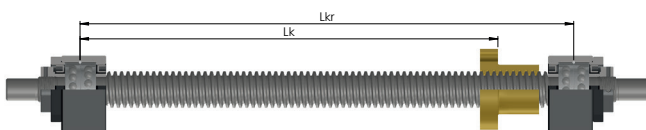

### Critical buckling force of ball screws

With slim components such as spindles there is a danger of lateral buckling under axial compressive loads. Using the procedure described below, the permissible, axial force can be determined according to the Euler-Case. The safety factors applying to the system must be considered before determining the permissible compressive force.

### Theoretically critical buckling force in [kN]:

$$F_k = \left( \frac{d_2}{L_k} \cdot 10^5 \right) : 1000$$

### Maximum permissible axial force in:

$$F_{zul} = F_k \cdot f_k \cdot \frac{1}{S_f}$$

$F_{zul}$	Maximum permissible axial force [kN]
$F_k$	Theoretically critical buckling force [kN]
$f_k$	Correction factor that takes into account the type of spindle bearing
$d_2$	Core diameter of the spindle [mm]
$L_k$	Unsupported length on which the force acts on the spindle [mm]
$S_f$	Safety factor (specified by the user)

### Caution!

The operating force must not exceed 80% of the maximum permissible axial force.

### Critical speed of ball screws

With slim, rotating components such as spindles there is a risk of resonant vibration. The procedure described below enables the resonant frequency to be estimated, assuming an adequately rigid installation. In addition, speeds close to the critical speed greatly increase the risk of lateral buckling. The critical speed must therefore also be considered in connection with the critical buckling force.

### Theoretically critical speed in [1/min]

$$F_{kr} = \left( \frac{d_2}{L_{kr}} \cdot 10^8 \right)$$

$n_{zul}$	Maximum permissible spindle speed [rpm]
$n_{kr}$	Theoretically critical spindle speed [rpm] that leads to resonant vibrations
$f_{kr}$	Correction factor that takes into account the type of spindle bearing
$d_2$	Core diameter of the spindle [mm]
$L_{kr}$	unsupported spindle length [mm]

### Caution!

The operating force must not exceed 80% of the maximum permissible axial force.

### Maximum permissible speed of rotation in [rpm]

$$f_{kr} = F_{kr} \cdot f_k \cdot 0,8$$

# Calculation

## Trapezoidal screw drive

### Theoretically permissible buckling force

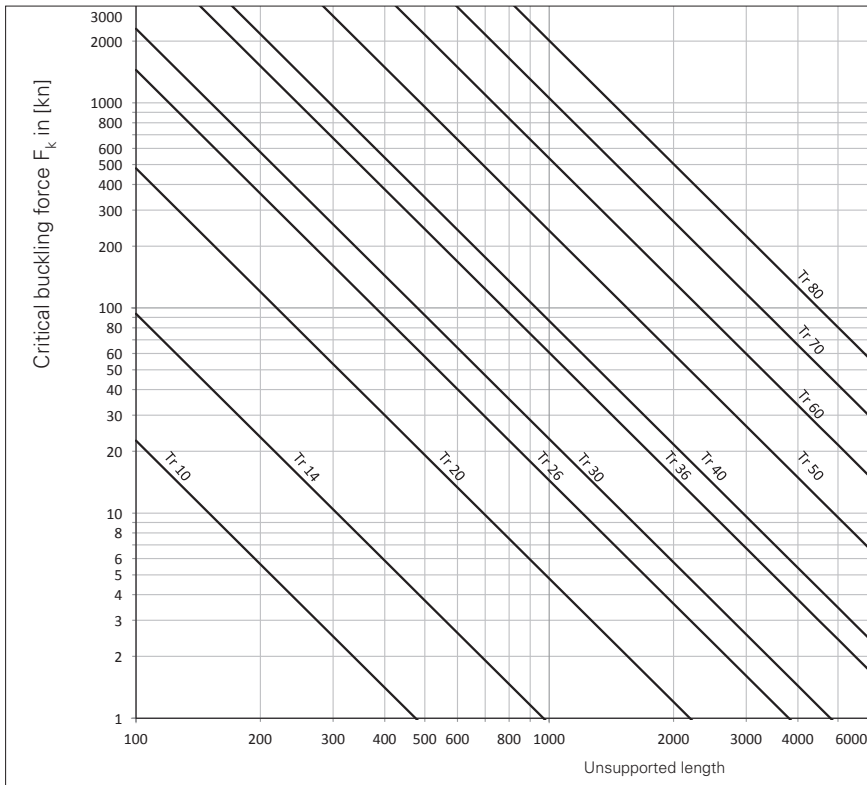

### Theoretically permissible speed:

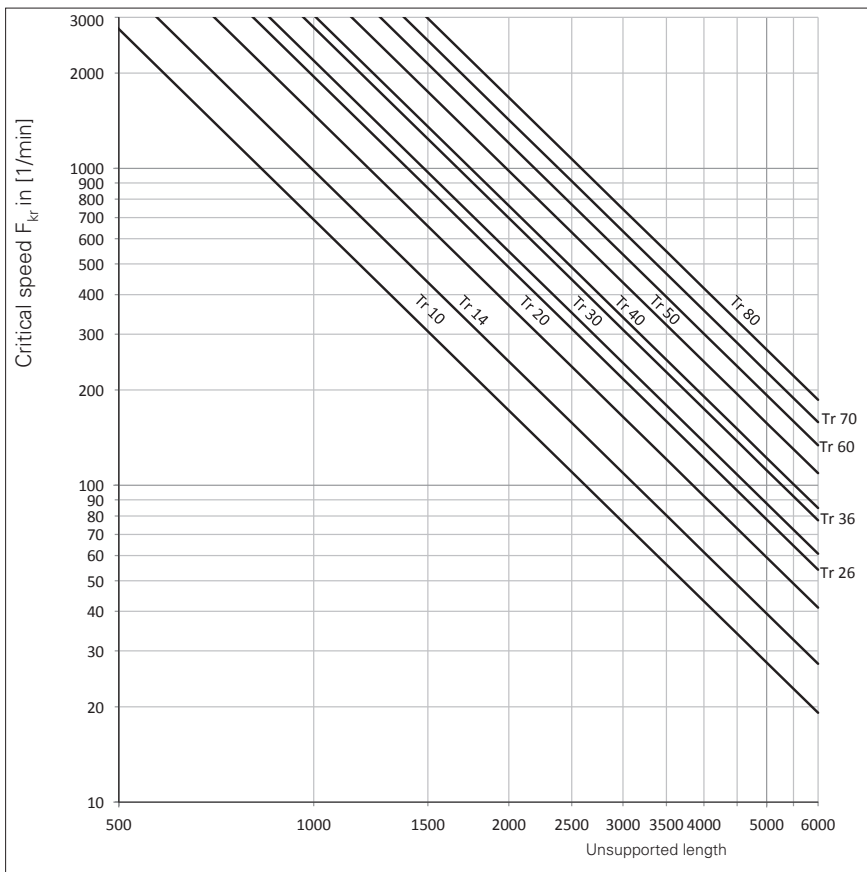

# Calculation

## Trapezoidal screw drive

### Required drive torque

$$M_d = \frac{F_{ax} \cdot P}{2000 \cdot \pi \cdot \eta_A} + M_{rot}$$

#### Note:

The required drive torque does not represent a criterion for the selection of the motor. The user must decide here, what power he considers necessary!

### Efficiency $\eta$ for other friction coefficients than $\mu = 0,1$

$$\eta = \frac{\tan \alpha}{\tan (\alpha + \rho')}$$

	$\mu$ in start-up ( $= \mu_0$ )		$\mu$ in motion	
	Dry	Lubricated	Dry	Lubricated
Metal nuts	$\approx 0,3$	$\approx 0,1$	$\approx 0,1$	$\approx 0,04$
Plastic nuts	$\approx 0,1$	$\approx 0,04$	$\approx 0,1$	$\approx 0,03$

### Required holding torque

$$M_d' = \frac{F_{ax} \cdot P \cdot \eta'}{2000 \cdot \pi} + M_{rot}$$

### Required drive torque and drive power

The required drive moment of a screw drive results from the acting axial load, the thread pitch and the efficiency of the screw drive and its bearing. In case of short acceleration times and high speeds the acceleration torque must be checked.

Fundamentally it must be noted that trapezoidal screw drives have to overcome a breakaway torque when starting up.

$F_{ax}$  Total acting axial force [N]  
 $P$  Thread pitch [mm]  
 $\eta_A$  Efficiency of the complete drive  
 $= \eta_{\text{Ball screw drive}} \cdot \eta_{\text{Fixed bearing}} \cdot \eta_{\text{Movable bearing}}$

$\eta_{\text{TGT}} (\mu = 0.1)$   
 $\eta_{\text{Fixed bearing}} = 0.9 \dots 0.95$   
 $\eta_{\text{Movable bearing}} = 0.95$

$M_d$  Required drive torque [Nm]  
 $M_{rot}$  Rotary acceleration torque [Nm]

$$= J_{rot} \cdot \alpha_0$$

$$= 7,7 \cdot d^4 \cdot L \cdot 10^{-13}$$

$J_{rot}$  Rotary mass moment of inertia [kgm<sup>2</sup>]  
 $d$  Nominal spindle diameter [mm]  
 $L$  spindle length [mm]  
 $\alpha_0$  Angular acceleration [rad/s<sup>2</sup>]

$\eta$  Efficiency for the transformation of a rotary motion into a longitudinal motion

$\alpha$  Pitch angle of the thread [°]:

$$\tan \alpha = \frac{P}{d_2 \cdot \pi}$$

with  $P$  P thread pitch [mm]  
 $d_2$  pitch diameter [mm]

$\rho'$  Thread friction angle [°]

$\tan \rho' = \mu \cdot 1,07$  for ISO trapezoidal threads  
 $\mu$  Friction coefficient

### Torque due to an axial load

Trapezoidal threads whose pitch angle  $\alpha$  is greater than the friction angle  $\rho'$ , are not considered to be self-locking. This means that an applied axial load generates a resulting torque on the spindle. The efficiency for the transformation of  $\eta'$  longitudinal motion into a rotary motion is lower than for the transformation of a rotary motion into a longitudinal motion.

$F_{ax}$  Total acting axial force [N]  
 $P$  thread pitch [mm]

$\eta'$  Efficiency for the transformation of a longitudinal motion into a rotary motion

$$= \frac{\tan (\alpha - \rho')}{\tan \alpha}$$

$$= 0,7 \cdot \eta$$

The influence of the efficiencies of the bearings can be neglected.

$M_d'$  Required holding torque [Nm]  
 $M_{rot}$  Rotary acceleration torque [Nm]

$$= J_{rot} \cdot \alpha_0$$

$$= 7,7 \cdot d^4 \cdot L \cdot 10^{-13}$$

$J_{rot}$  Rotary mass moment of inertia [kgm<sup>2</sup>]  
 $d$  Nominal spindle diameter [mm]  
 $L$  spindle length [mm]  
 $\alpha_0$  Angular acceleration [rad/s<sup>2</sup>]

# Screw end machining for movable/fixed bearing Form D, F

The type of bearing influences the stiffness of the entire screw drive, and also the vibration and buckling behaviour of the threaded spindle. The end machining is carried out on the ball screw as necessary for the various types of bearing.

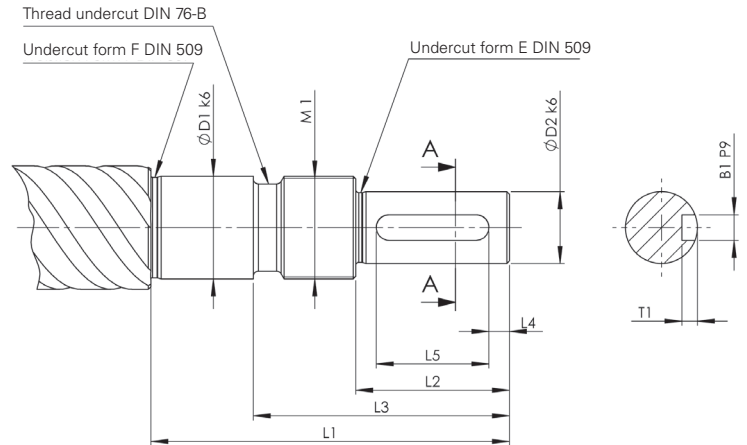

Form D	Dimensions [mm]									Bearing
TGS/GGS/KGS	D <sub>1</sub>	D <sub>2</sub>	L <sub>1</sub>	L <sub>2</sub>	L <sub>3</sub>	L <sub>4</sub>	L <sub>5</sub>	M <sub>1</sub>	B <sub>1</sub> xT <sub>1</sub>	ZKLf...2RS
Thread core diameter d <sub>2</sub> > d <sub>1</sub>	12	9	55	20	32	2.5	16	M 12x1	3x1.8	1255
	15	11	58	23	35	3.5	16	M 15x1	4x2.5	1560
	20	14	70	30	44	4	22	M 20x1	5x3	2068
	25	19	82	40	57	6	28	M 25x1.5	6x3.5	2575
	30	24	92	50	67	7	36	M 30x1.5	8x4	3080

Form F	Dimensions [mm]									Bearing
TGS/GGS/KGS	D <sub>1</sub>	D <sub>2</sub>	L <sub>1</sub>	L <sub>2</sub>	L <sub>3</sub>	L <sub>4</sub>	L <sub>5</sub>	M <sub>1</sub>	B <sub>1</sub> xT <sub>1</sub>	ZARN...LTN
Thread core diameter d <sub>2</sub> > d <sub>1</sub>	15	11	73	23	35	3.5	16	M 15x1	4x2.5	1545
	20	14	88	30	45	4	22	M 20x1	5x3	2052
	20	14	107	30	50	4	22	M 20x1	5x3	2062
	25	19	105	40	58	6	28	M 25x1.5	6x3.5	2557
	25	19	120	40	63	6	28	M 25x1.5	6x3.5	2572
	35	28	145	60	82	10	40	M 35x1.5	8x4	3585
	40	36	175	80	103	8.5	63	M 40x1.5	10x5	4090

## Screw end machining for movable/fixed bearing Form H, J, L

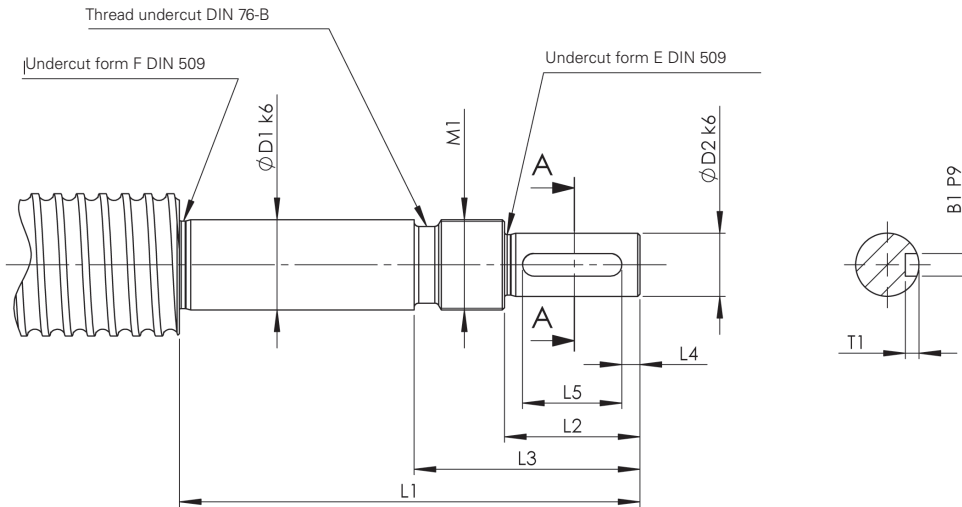

Form H TGS/GGS/KGS	Dimensions [mm]									Bearing ZARF...LTN
	$D_1$	$D_2$	$L_1$	$L_2$	$L_3$	$L_4$	$L_5$	$M_1$	$B_1 \times T_1$	
Thread core diameter $d_2 > d_1$	15	11	85	23	35	3,5	16	M 15x1	4x2,5	1560
	20	14	102	30	44	4	22	M 20x1	5x3	2068
	20	14	122	30	49	4	22	M 20x1	5x3	2080
	25	19	120	40	57	6	28	M 25x1,5	6x3,5	2575
	25	19	135	40	63	6	28	M 25x1,5	6x3,5	2590
	35	28	160	60	81	10	40	M 35x1,5	8x4	35110
	40	36	195	80	105	8,5	63	M 40x1,5	10x5	40115

Form J TGS/GGS/KGS	Dimensions [mm]									Bearing FDX
	$D_1$	$D_2$	$L_1$	$L_2$	$L_3$	$L_4$	$L_5$	$M_1$	$B_1 \times T_1$	
Thread core diameter $d_2 > d_1$	12	9	88	20	32	2,5	16	M 12x1	3x1,8	12
	15	11	92	23	35	3,5	16	M 15x1	4x2,5	15
	20	14	107	30	44	4	22	M 20x1	5x3	20
	25	19	122	40	57	6	28	M 25x1,5	6x3,5	25
	30	24	136	50	72	7	36	M 30x1,5	8x4	30
	40	36	182	80	102	8,5	63	M 40x1,5	10x5	40

Form L TGS/GGS/KGS	Dimensions [mm]									Bearing
	$D_1$	$D_2$	$L_1$	$L_2$	$L_3$	$L_4$	$L_5$	$M_1$	$B_1 \times T_1$	
Thread core diameter $d_2 > d_1$	12	9	58	20	30	2,5	16	M 12x1	3x1,8	7201 BE RS
	15	11	73	23	33	3,5	16	M 15x1	4x2,5	7202 BE RS
	20	14	88	30	43	4	22	M 20x1	5x3	7204 BE RS
	25	19	120	40	55	6	28	M 25x1,5	6x3,5	7205 BE RS
	35	28	145	60	77	10	40	M 35x1,5	8x4	7207 BE RS
	40	36	175	80	103	8,5	63	M 40x1,5	10x5	7208 BE RS

Form A  
 Chamfer 2 x 45°: KGS from  $\phi$  12 – 25 mm  
 Chamfer 3 x 45°: KGS from  $\phi$  26 – 40 mm  
 Chamfer 4 x 45°: KGS from  $\phi$  44 – 50 mm

# Screw end machining for movable/fixed bearing Form S, T, W

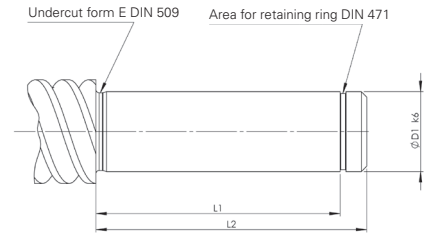

Form S TGS/GGS/KGS	Dimensions [mm]			Spacer bush	Bearing
	D <sub>1</sub>	L <sub>1</sub>	L <sub>2</sub>		
Thread core diameter $d_2 > d_1$	12	40	45	18x12.1x24	6001 RS
	15	46	51	21x15.1x28	6002 RS
	20	53	58	27x20.1x29	6004 RS
	25	53	58	32x25.1x23	6205 RS
	30	60	68	40x30.1x28	6206 RS
	40	80	88	50x40.1x44	6208 RS
	55	102	110	65x55.1x60	6211 RS

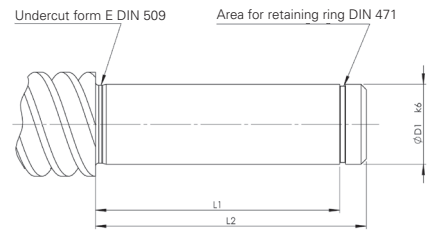

Form T TGS/GGS/KGS	Dimensions [mm]			Inner ring	Needle bearing
	D <sub>1</sub>	L <sub>1</sub>	L <sub>2</sub>		
Thread core diameter $d_2 > d_1$	12	40	45	2 IR 12x16x20	HK 1614 RS
	15	46	51	2 IR 15x20x23	HK 2018 RS
	20	53	58	2 LR 20x25x26.5	HK 2518 RS
	25	53	58	2 LR 25x30x26.5	HK 3018 RS
	30	60	68	2 LR 30x35x30	HK 3518 RS
	40	80	88	4 LR 40x45x20	HK 4518 RS

Form G: Screw end annealed to customer's specification.

Form K: Produced specially to customer's drawing

Form W TGS/GGS/KGS	Dimensions [mm]			Bearing
	D <sub>1</sub>	L <sub>1</sub>	L <sub>2</sub>	
Thread core diameter $d_2 > d_1$	12	8	12	6001 RS
	15	9	13	6002 RS
	20	12	16	6004 RS
	25	15	20	6205 RS
	30	16	21	6206 RS
	40	18	25	6208 RS
55	21	29	6211 RS	

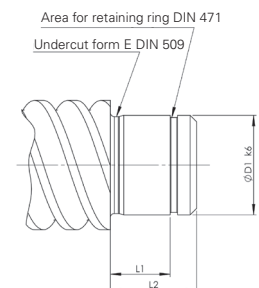



# Screw end machining

Form FK - FF - BK - BF

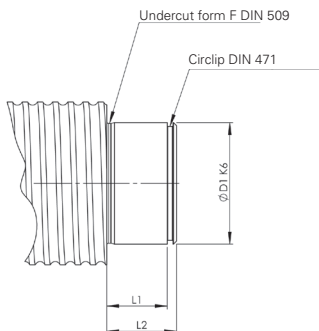
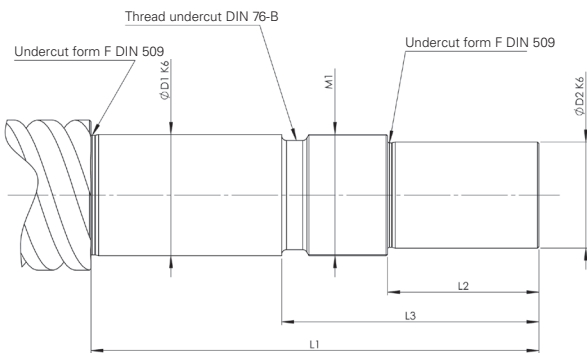
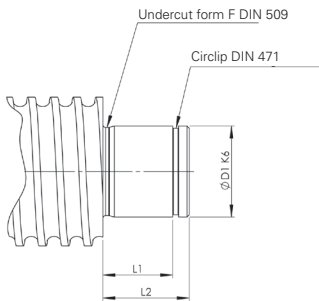
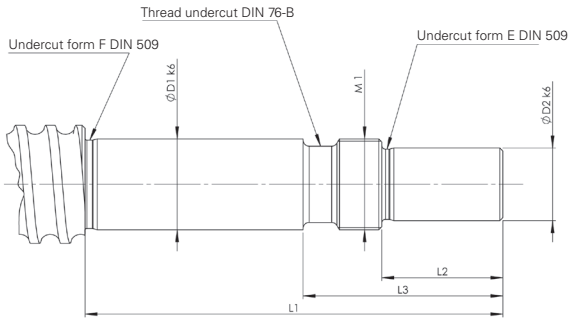

Designation	$\varnothing D_{1 k6}$	$\varnothing D_{2 k6}$	$L_1$	$L_2$	$L_3$	M1
FK 6	6	4	38	8	16	M6x0.75
FK 8	8	6	44	9	19	M8x1
FK 10	10	8	51	15	26	M10x1
FK 12	12	10	51	15	26	M12x1
FK 15	15	12	69	20	33	M15x1
FK 20	20	17	89	25	42	M20x1
FK 25	25	20	106	30	50	M25x1.5
FK 30	30	25	110	38	63	M30x1.5

Designation	$\varnothing D_{1 k6}$	$L_2$	$L_1$
FF 10	8	10	7
FF 12	10	11	8
FF 15	15	13	9
FF 20	20	19	14
FF 25	25	20	15
FF 30	30	21	16

Designation	$\varnothing D_{1 k6}$	$\varnothing D_{2 k6}$	$L_1$	$L_2$	$L_3$	M1
BK 10	10	8	54	15	31	M10x1
BK 12	12	10	54	15	29	M12x1
BK 15	15	12	60	20	32	M15x1
BK 17	17	15	76	23	40	M17x1
BK 20	20	17	78	25	40	M20x1
BK 25	25	20	95	30	48	M25x1.5
BK 30	30	25	110	38	63	M30x1.5
BK 35	35	30	128	45	73	M35x1.5
BK 40	40	35	148	50	85	M40x1.5

Designation	$\varnothing D_{1 k6}$	$L_2$	$L_1$
BF 10	8	10	7
BF 12	10	11	8
BF 15	15	13	9
BF 17	17	16	12
BF 20	20	16	12
BF 25	25	20	15
BF 30	30	21	16
BF 35	35	22	17
BF 40	40	23	18

# Fixed bearing units BK-BF

## Fixed bearing unit BK

This fixed bearing unit is a pedestal bearing with pre-tensioned axial inclined ball bearings with seals.

The fixed bearing unit is comprised of a burnished steel bearing case with 2 axial inclined ball bearings pre-tensioned by means of a flange, 2 seals with circlips and a securable DRS grooved nut. (Square nuts are used for the smaller sizes).

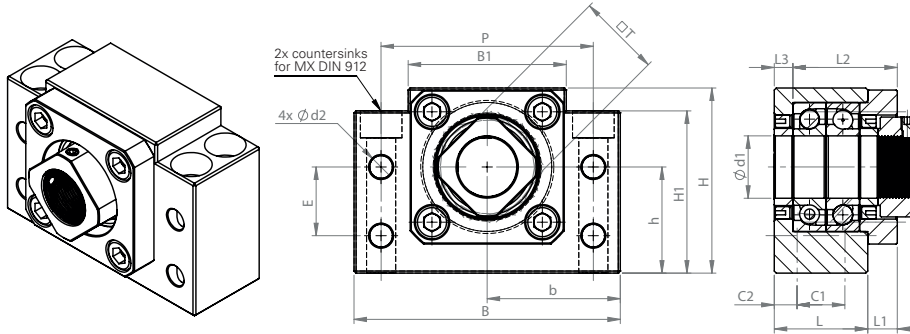

Size	Dimensions in mm																				Bearing designation	C <sub>stat</sub> in [kN]	C <sub>dyn</sub> in [kN]	Weight	
	Ø d1	L	L1	L2	L3	B	H	b±0,02	h±0,02	B1	H1	E	P	C1	C2	d2	X	Y	Z	M					T
BK10	10	25	5	29.5	5	60	39	30	22	34	32.5	15	46	13	6	5.5	6.6	10.8	5	M3	16	7000	5.2	1.9	0.4
BK12	12	25	5	29.5	5	60	43	30	25	34	32.5	18	46	13	6	5.5	6.6	10.8	1	M4	19	7001	6	2.1	0.4
BK15	15	27	6	32	6	70	48	35	28	40	38	18	54	15	6	5.5	6.6	11	65	M4	22	7002	6.9	2.4	0.6
BK17	17	35	9	44	7	86	64	43	39	50	55	28	68	19	8	6.6	9	14	85	M4	24	7203	12	4.1	1.3
BK20	20	35	8	43	8	88	60	44	34	52	50	22	70	19	8	6.6	9	14	85	M4	30	7004	13.1	4.2	1.3
BK25	25	42	12	54	9	106	80	53	48	64	70	33	85	22	10	9	11	17	11	M5	35	7205	20.5	7	2.4
BK30	30	45	14	61	9	128	89	64	51	76	78	33	102	23	11	11	14	20	13	M6	40	7206	27.1	9.2	3.4
BK35	35	50	14	67	12	140	96	70	52	88	79	35	114	26	12	11	14	20	13	M8	50	7207	36.8	14.4	4.4
BK40	40	61	18	76	15	160	110	80	60	100	90	37	130	33	14	14	18	26	175	M8	50	7208	46.1	18	6.8

## Movable bearing unit BF

This movable bearing unit is a pedestal bearing with a deep-groove ball bearing that adapts itself axially to the elongation of the spindle.

The movable bearing unit consists of a burnished steel bearing case with a deep groove ball bearing.

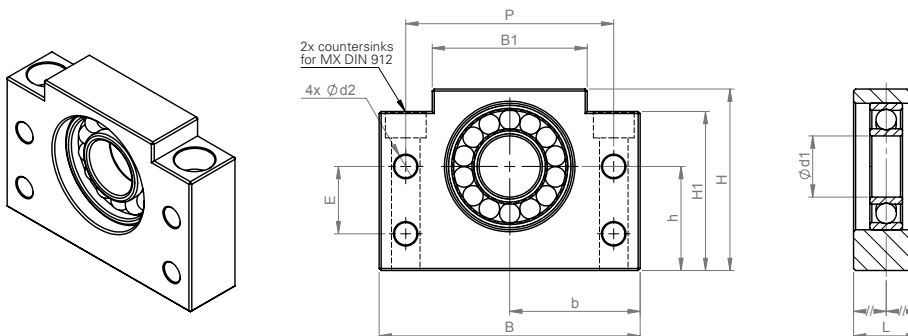

Size	Dimensions in mm														Bearing designation	C <sub>stat</sub> in [kN]	C <sub>dyn</sub> in [kN]	Weight
	Ø d1	L	B	H	b±0,02	h±0,02	B1	H1	E	P	d2	X	Y	Z				
BF10	8	20	60	39	30	22	34	32.5	15	46	5.5	6.6	10.8	5	7000	5.2	1.9	0.4
BF12	10	20	60	43	30	25	34	32.5	18	46	5.5	6.6	10.8	1.5	7001	6	2.1	0.4
BF15	15	20	70	48	35	28	40	38	18	54	5.5	6.6	11	6.5	7002	6.9	2.4	0.6
BF17	17	23	86	64	43	39	50	55	28	68	6.6	9	14	8.5	7203	12	4.1	1.3
BF20	20	26	88	60	44	34	52	50	22	70	6.6	9	14	8.5	7004	13.1	4.2	1.3
BF20H	20	26	88	74	44	48	52	64	-	70	-	9	14	8.5	7205	20.5	7	2.4
BF25	25	30	106	80	53	48	64	70	33	85	9	11	17	11	7206	27.1	9.2	3.4
BF30	30	32	128	89	64	51	76	78	33	102	11	14	20	13	7207	36.8	14.4	4.4
BF35	35	32	140	96	70	52	88	79	35	114	11	14	20	13	7208	46.1	18	6.8
BF40	40	37	160	110	80	60	100	90	37	130	14	18	26	41411				

# Fixed bearing units FK-FF

## Fixed bearing unit FK

This fixed bearing unit is a flanged bearing with pre-tensioned axial inclined ball bearings with seals.

The fixed bearing unit is comprised of a burnished steel bearing case with 2 axial inclined ball bearings pre-tensioned by means of a flange, 2 seals with circlips and a securable DRS grooved nut. (Square nuts are used for the smaller sizes).

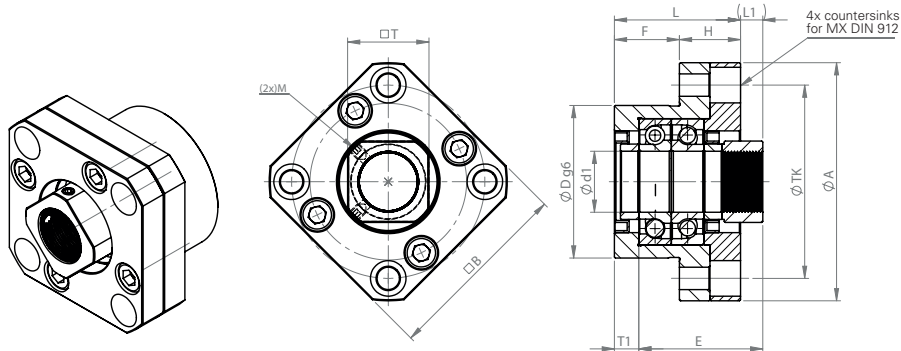

Size	Dimensions in mm																			Bearing designation	C <sub>stat</sub> in [kN]	C <sub>dyn</sub> in [kN]	Weight	
	Ø d1	L	H	F	E	D g6	A	TK	B	L1	T1	L2	T2	X	Y	Z	M	T	G					Q
FK05	5	16.5	6	10.5	18.5	20	34	26	26	5.5	3.5	5	3	3.4	6.5	4	M3	11	-	-	605	0.5	0.3	0.1
FK06	6	20	7	13	22	22	36	28	28	5.5	3.5	6.5	4.5	3.4	6.5	4	M3	12	-	-	706A	1	0.7	0.12
FK08	8	23	9	14	26	28	43	35	35	7	4	8	5	3.4	6.5	4	M3	14	-	-	708A	2.7	1	0.16
FK10	10	27	10	17	29.5	34	52	42	42	7.5	5	8.5	6	4.5	8	4	M3	16	-	M6	7000A	5.2	1.9	0.25
FK12	12	27	10	17	29.5	36	54	44	44	7.5	5	8.5	6	4.5	8	4	M4	19	-	M6	7001A	6	2.1	0.26
FK15	15	32	15	17	36	40	63	50	52	10	6	12	8	5.5	9.5	6	M4	22	26	M6	7002A	6.9	2.4	0.4
FK17	17	45	22	23	47	50	77	62	61	11	9	14	12	6.6	11	10	M4	24	30.5	M6	7203A	12	4.1	0.85
FK20	20	52	22	30	50	57	85	70	68	8	10	12	14	6.6	11	10	M4	30	34	M6	7204A	13.1	4.2	1.2
FK25	25	57	27	30	59	63	98	80	79	13	10	20	17	9	15	13	MS	35	39.5	M6	7205A	20.5	7	1.6
FK30	30	62	30	32	61	75	117	95	93	11	12	17	18	11	17.5	15	M6	40	46.5	M6	7206A	27.1	9.2	2.38

## Movable bearing units FF

This movable bearing unit is a flanged bearing with a deep-groove ball bearing that adapts itself axially to the elongation of the spindle. The movable bearing unit consists of a burnished steel bearing case with a deep groove ball bearing.

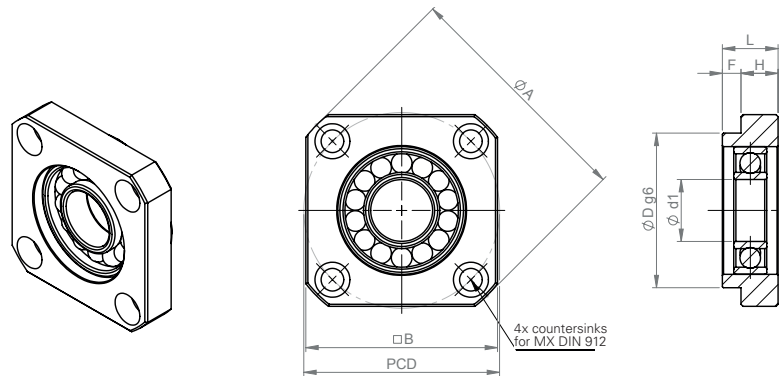

Size	Dimensions in mm											Bearing designation	C <sub>stat</sub> in [kN]	C <sub>dyn</sub> in [kN]	Weight
	Ø d1	L	H	F	D g6	A	TK	B	X	Y	Z				
FF 06	6	10	6	4	22	36	28	28	3.4	6.5	4	606ZZ	2	0.7	0.08
FF 10	8	12	7	5	28	43	35	35	3.4	6.5	4	608ZZ	5.2	1.9	0.1
FF 12	10	15	7	8	34	52	42	42	4.5	8	4	6000ZZ	6	2.1	0.15
FF 15	15	17	9	8	40	63	50	52	5.5	9.5	5.5	6002ZZ	6.9	2.4	0.22
FF 17	17	20	11	9	50	77	62	61	6.6	11	6.5	6203ZZ	12	4.1	0.35
FF 20	20	20	11	9	57	85	70	68	6.6	11	6.5	6204ZZ	13.1	4.2	0.45
FF 25	25	24	14	10	63	98	80	79	9	14	8.5	6205ZZ	20.5	7	0.66
FF 30	30	27	18	9	75	117	95	93	11	17	11	6206ZZ	27.1	9.2	1.05

# Grooved nuts

## DRS

This is a securable grooved nut that is secured by two radial brass pins.

Material: heat treated steel, min. 800 N/mm<sup>2</sup>

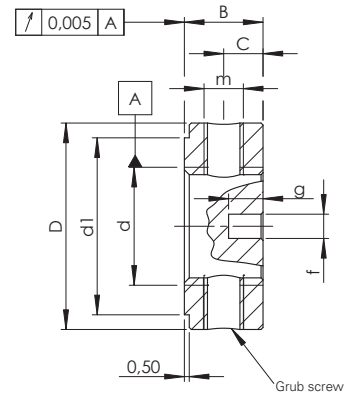
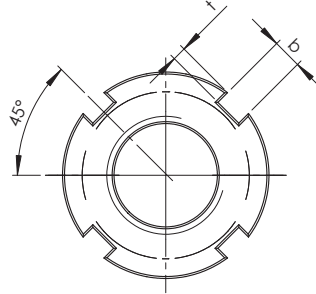

Size	d	D	B	d <sub>1</sub>	c	m	b	t	e	f	g	(Nm)
DRS 6x0.5	M 6x0.5	16	8	12	4	M4	3	2	11	2.5	3.5	2
DRS 10x1	M 10x1	18	8	14	4	M4	3	2	14	2.5	3.5	6
DRS 12x1	M 12x1	22	8	18	4	M4	3	2	17	2.5	3.5	8
DRS 17x1	M 17x1	28	10	23	5	M5	4	2	22.5	3	4	15
DRS 20x1	M 20x1	32	10	27	5	M5	4	2	26	3	4	18
DRS 30x1.5	M 30x1.5	45	12	40	6	M6	5	2	37.5	4	5	32
DRS 45x1.5	M 45x1.5	65	14	59	7	M6	6	2.5				65
DRS 55x2	M 55x2	75	16	68	8	M6	7	3				95
DRS 60x2	M 60x2	80	16	73	8	M6	7	3				100
DRS 70x2	M 70x2	92	18	85	9	M8	8	3.5				130
DRS 80x2	M 80x2	105	18	95	9	M8	8	3.5				160
DRS 90x2	M 90x2	120	20	108	10	M8	10	4				200

## GUK

Self-locking grooved nut with polyamide ring.

Secured by a polyamide ring - usable up to max. 100 °C.

Material (strength class): min. 14 H, galvanised and passivated

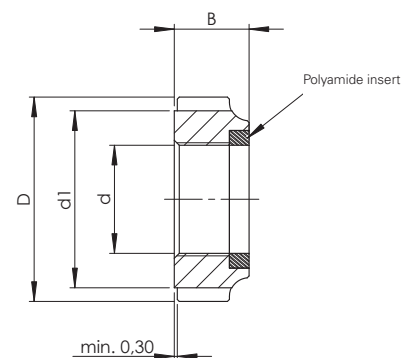
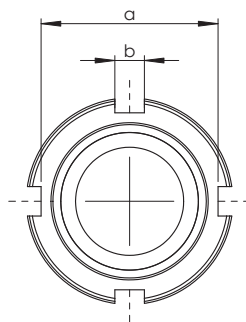

Size	d	D	B	d <sub>1</sub>	a	b	(Nm)	Weight
GUK 12x1	M 12x1	21	7.6	18	18	3	8	10
GUK 15x1	M 15x1	24	8.6	21	21	4	10	13
GUK 20x1	M 20x1	32	9.6	27	27	4	18	24

# Adaptor bracket KON

Adaptor bracket for radial fastening of trapezoidal-threaded flanged nuts EFM or ball screw flanged nuts KGF-N/KGF-D according to DIN 69051.

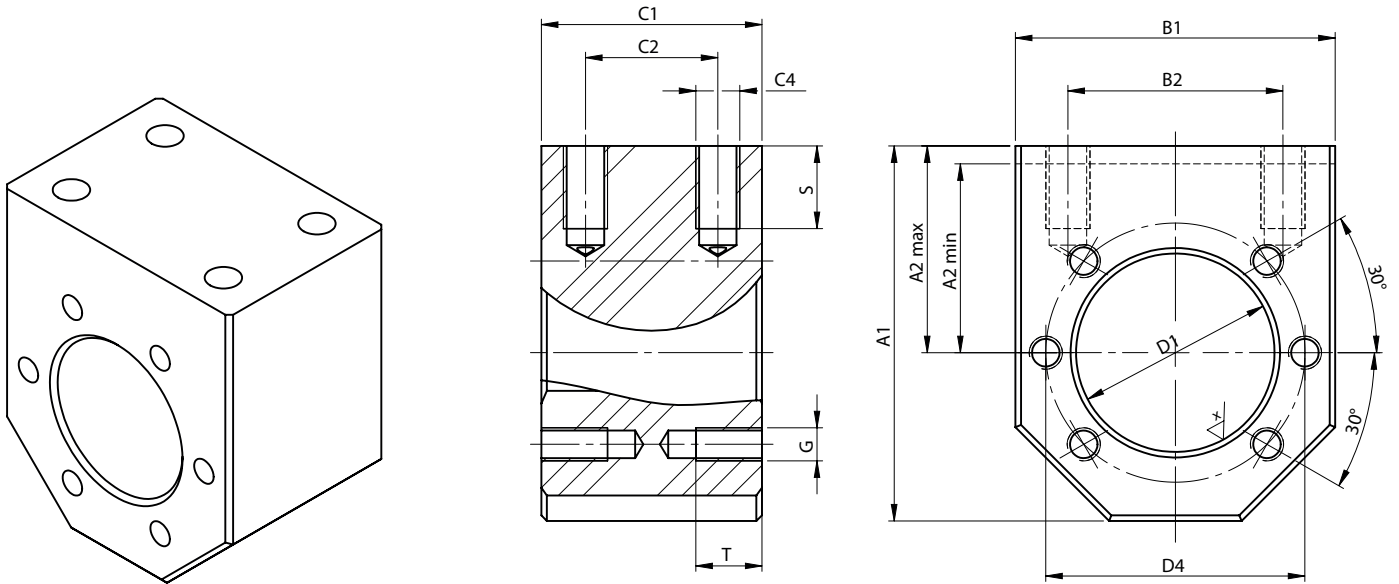

Size	Hole pattern <sup>1)</sup>	A1	A2 max	A2 min	B1	B2	C1	C2	C4	S	D1	D4	G	T
KON Tr 16x4/Tr 18x4/KGF-N 1605	3	60	35	25	50	34	40	24	M8	15	28	38	M5	10
KON KGF-D 1605/1610	1	60	35	25	50	34	40	24	M8	15	28	38	M6	10
KON Tr 20x4/Tr 24x5/KGF-N 2005	3	68	37.5	29	58	39	40	24	M8	15	32	45	M6	12
KON KGF-D 2005	1	68	37.5	30	58	39	40	24	M8	15	36	47	M7	12
KON KGF-D 2020/2050	3	75	42.5	32.5	65	49	40	24	M10	15	35	50	M6	12
KON Tr 30x6/KGF-N 2505	3	75	42.5	32.5	65	49	40	24	M10	15	38	50	M6	12
KON KGF-D 2505/2510/2520/2525/2550	1	75	42.5	32.5	65	49	40	24	M10	12	40	51	M6	12
KON Tr 36x6/KGF-N 3205	3	82	45	37	75	54	50	30	M10	12	45	58	M6	12
KON KGF-D 3205	1	92	50	40	85	60	50	30	M12	15	50	65	M8	12
KON KGF-N 3210/3240/4005	3	92	50	42	85	60	50	30	M12	15	53	68	M6	12
KON KGF-D 3210/3220	1	92	50	40	85	60	50	30	M12	15	53	65	M8	12
KON Tr 40x7/KGF-N 4010	3	120	70	50	100	76	65	41	M14	25	63	78	M8	14
KON KGF-D 4005/4010/4020/4040	2	120	70	50	100	76	65	41	M14	25	63	78	M8	14
KON Tr 50x8/KGF-N 5010	3	135	77.5	57.5	115	91	88	64	M16	25	72	90	M10	16
KON KGF-D 5010	2	135	77.5	57.5	115	91	88	64	M16	25	75	93	M10	16
KON KGF-D 5020	2	152	87.5	65	130	101	88	64	M16	30	85	103	M10	16
KON Tr 60x9/KGF-N 6310	3	152	87.5	65	130	101	88	64	M16	30	85	105	M10	16

<sup>1)</sup> See catalogue illustration of nut hole pattern

# Universal joint adapter KAR

Universal joint adaptor for universal mounting of trapezoidal-threaded flanged nuts EFM or ball screw flanged nuts KGF-N/KGF-D according to DIN 69051

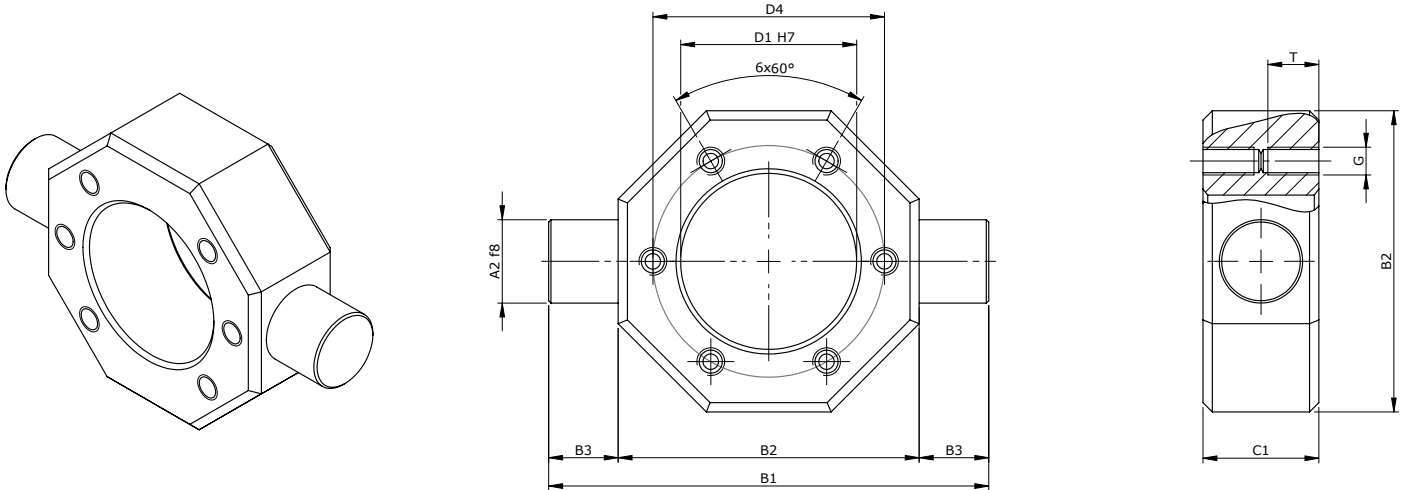

Size	Hole pattern <sup>1)</sup>	A2	B1	B2	B3	C1	D1	D4	G	T
KAR Tr 16x4/Tr 18x4/KGF-N 1605	3	12	70	50	10	20	28	38	M5	10
KAR KGF-D 1605/1610	1	12	70	50	10	20	28	38	M5	10
KAR Tr 20x4/Tr 24x5/KGF-N 2005	3	16	85	58	13.5	25	32	45	M6	12
KAR KGF-D 2005	1	16	85	58	13.5	25	36	47	M6	12
KAR KGF-N 2020/2050	3	18	95	65	15	25	35	50	M6	12
KAR Tr 30x6/KGF-N 2505	3	18	95	65	15	25	38	50	M6	12
KAR KGF-D 2505/2510/2520/2525/2550	1	18	95	65	15	25	40	51	M6	12
KAR Tr 36x6/KGF-N 3205	3	20	110	75	17.5	30	45	58	M6	12
KAR KGF-D 3205	1	25	125	85	20	30	45	58	M8	12
KAR KGF-N 3210/3240/4005	3	25	125	85	20	30	53	68	M6	12
KAR KGF-D 3210/3220	1	25	125	85	20	30	53	65	M8	12
KAR Tr 40x7/KGF-N 4010	3	30	140	100	20	40	63	78	M8	14
KAR KGF-D 4005/4010/4020/4040	2	30	140	100	20	40	63	78	M8	14
KAR Tr 50x8/KGF-N 5010	3	40	165	115	25	50	72	90	M10	16
KAR KGF-D 5010	2	40	165	115	25	50	72	93	M10	16
KAR KGF-D 5020	2	40	180	130	25	50	85	103	M10	16
KAR Tr 60x9/KGF-N 6310	3	40	180	130	25	50	85	105	M10	16

<sup>1)</sup> See catalogue illustration of nut hole pattern

# Bellows FB

For the protection of the spindle against external influences. Available in diameters from 20 mm to 120 mm in 1 mm steps. Horizontal and vertical installation possible.

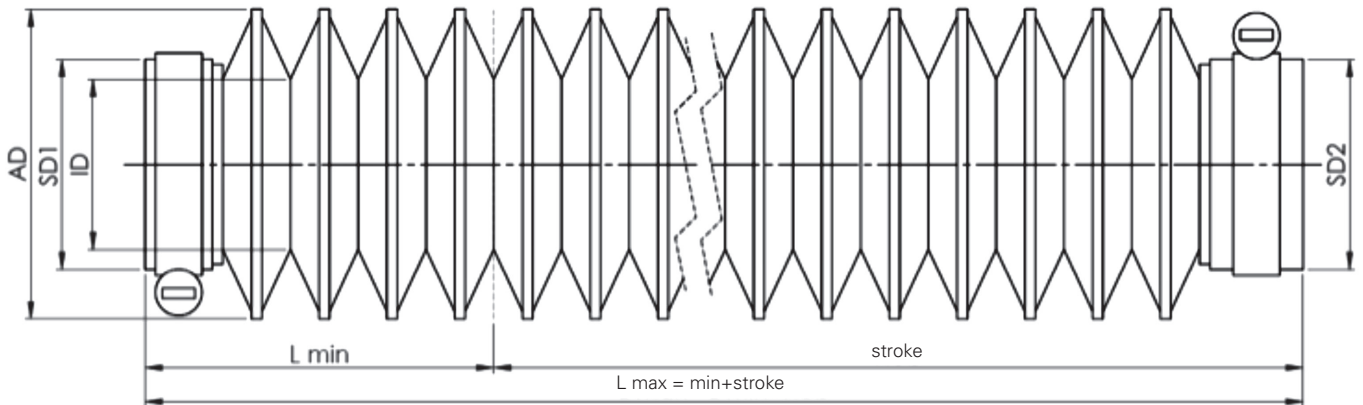

## Calculation of bellows FB

For the dimensioning of the spindle length of screw jacks or screw drives with bellows protection, the spindle must be extended by Lmin.

### TO version (thermoplastic sprayed)

$$L_{min} = F_z \cdot L_{minF}$$

$$F_z = \frac{L_{max}}{F_t} : 1,8$$

$$F_t = \frac{AD - ID}{2}$$

$$L_{minF} = 6 \text{ mm}$$

If space is limited, LminF can be shortened after consultation to the factor 0.835.

### SB version (disk bellows)

$$L_{min} = F_z \cdot L_{minF}$$

$$F_z = \frac{L_{max}}{F_t} : 1,1$$

$$F_z = \frac{L_{max}}{F_t} : 1,1$$

$$F_t = \frac{AD - ID}{2}$$

$$L_{minF} = 2,5 \text{ mm}$$

Lmin	compressed length [mm]
Lmax	extended length [mm]
Ft	fold depth [mm]
Fz	no. of folds
LminF	compressed length per fold [mm]

If space is limited, LminF can be shortened after consultation to the factor 0.64.

A support ring must be installed every 400 mm in case of horizontal installation or every 1000 mm in case of vertical installation. The dimension Lmin is extended here by 1.1 mm per support ring.

# Ordering code

bellows FB

## Ordering code for bellows FB

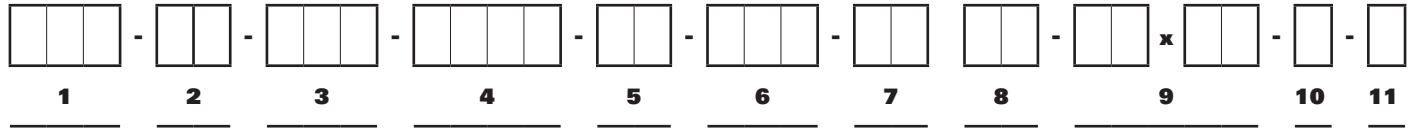

No.	Designation	Code	Description
1	Product abbreviation	<b>KGT</b>	Ball screw
2	Design	<b>TO</b>	Thermoplastic (sprayed)
		<b>SB</b>	Disk bellows
		<b>GR</b>	Round fabric, coated
		<b>GV</b>	Polygonal fabric, coated
3	Lmin in [mm]		Retraction length / compressed length of bellows
4	Stroke/Lmax in [mm]		Stroke/maximum extension length
5	Inside diameter ID in [mm]		> same as diameter of spindle
6	Outside diameter AD in [mm]		Outside diameter of bellows
7	Cuff diameter SD1 in [mm]		Inside diameter of bellows ending 1
8	Cuff diameter SD2 in [mm]		Inside diameter of bellows ending 2
9	Spindle dimension		e.g. 20x4 (diameter 20 mm, pitch 4 mm)
10	Installation position	<b>H</b>	Horizontal
		<b>V</b>	Vertical
11	Special requirements nut	<b>0</b>	none
		<b>1</b>	According to specification, description or drawing



# Spiral spring cover SF

Spiral springs are used as reliable spindle protective covers against external influences.

The material used is hardened spring band steel. If the spiral springs are exposed to cooling lubricants with a high water content, it is recommended to use rustproof spiral springs. (Sizes on enquiry)

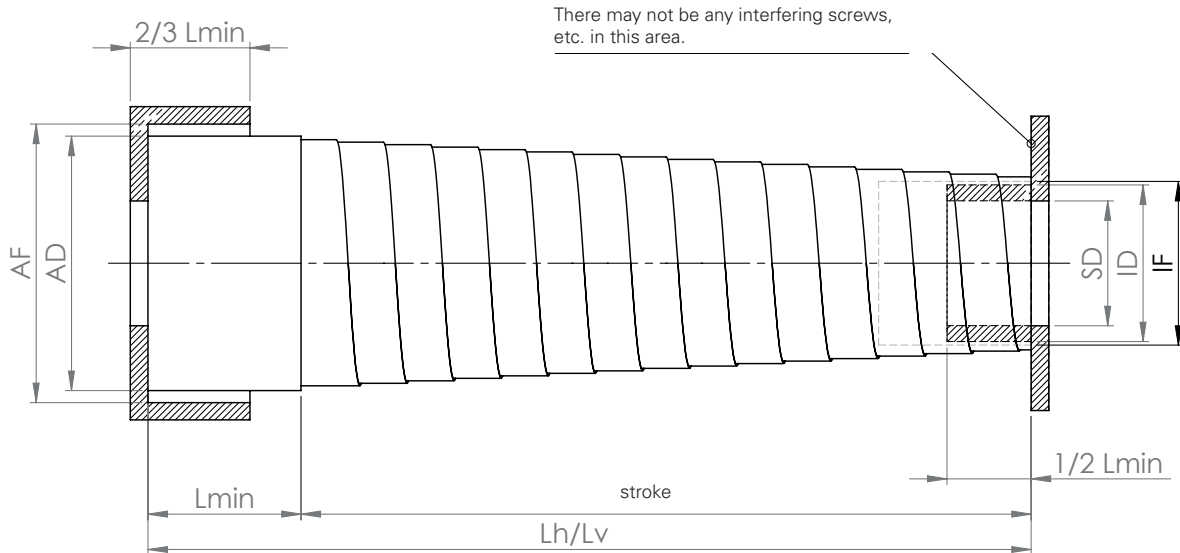

SD = Maximum outside diameter / spindle diameter  
 ID = Inside diameter of the spiral spring  $\pm 1$  mm  
 AD = Diameter of the spiral spring  
 Lh = Maximum extension length in case of horizontal installation

Lv = Maximum extension length in case of vertical installation  
 BB = Width of band, corresponds to Lmin  
 AF = Inside diameter of the centring flange AD +4 mm  
 IF = Outside diameter of the centring flange ID -2 mm

## For KGT-Dm 12-16 For TGT-Dm 12-18

Spiral spring SF	SD	AD	Lh
25-100-15	21	36	100
25-100-20	21	36	100
25-120-20	21	36	100
25-150-20	21	38	150
25-150-30	21	36	150
25-200-20	21	40	200
25-200-30	21	38	200
25-250-20	21	44	200
25-250-30	21	40	200
25-250-40	21	39	200
25-250-50	21	41	200
25-300-20	21	46	250
25-300-30	21	42	250
25-320-20	21	45	320
25-350-30	21	45	300
25-350-40	21	42	300
25-400-30	21	48	350
25-400-40	21	44	350
25-450-30	21	49	400
25-450-40	21	48	400
25-450-50	21	41	400
25-500-30	21	52	450
25-500-40	21	49	450
25-500-50	21	42	450
25-550-50	21	43	500

## For KGT-Dm 20-25 For TGT-Dm 20-28

Spiral spring SF	SD	AD	Lh
30-100-20	26	43	100
30-150-20	26	45	150
30-150-30	26	39	150
30-150-50	26	40	150
30-200-30	26	42	200
30-220-30	26	43	220
30-250-20	26	51	na
30-250-25	26	41	250
30-250-30	26	44	250
30-250-50	26	42	250
30-300-30	26	46	250
30-300-35	26	43	na
30-350-30	26	49	350
30-350-35	26	41	350
30-350-40	26	48	350
30-350-50	26	45	350
30-400-30	26	50	350
30-400-35	26	44	400
30-400-50	26	46	na
30-450-30	26	53	400
30-450-35	26	53	na
30-450-40	26	53	450
30-550-50	26	68	550
30-700-40	26	64	700
30-900-75	26	55	800

## For KGT-Dm 32 For TGT-Dm 30-36

Spiral spring SF	SD	AD	Lh
40-60-20	36	48	60
40-70-30	36	50	70
40-150-20	36	53	150
40-170-30	36	54	150
40-200-20	36	62	150
40-250-30	36	56	200
40-300-25	36	58	200
40-350-30	36	60	350
40-400-30	36	64	400
40-450-30	36	64	450
40-500-30	36	68	500
40-550-40	36	68	550
40-600-50	36	63	600
40-650-50	36	65	650
40-660-75	36	64	660
40-700-40	36	71	700
40-700-50	36	66	700
40-700-60	36	64	700
40-750-50	36	69	750
40-750-60	36	66	750
40-750-75	36	66	750
40-800-60	36	67	800
40-800-75	36	68	800
40-850-50	36	71	850
40-850-60	36	68	850

## For KGT-Dm 32 For TGT-Dm 30-36

Spiral spring SF	SD	AD	Lh
40-900-60	36	70	900
40-900-75	36	71	900
40-950-50	36	82	950
40-950-60	36	71	950
40-1000-50	36	84	1000
40-1000-60	36	72	1000
40-1000-75	36	75	1000
40-1000-100	36	68	1000
40-1100-60	36	82	1100
40-1100-75	36	78	1100
40-1200-75	36	81	1200
40-1200-100	36	71	1200
40-1300-75	36	84	1300
40-1300-100	36	75	1300
40-1400-100	36	76	1400
40-1500-75	36	90	1500
40-1500-100	36	78	1500
40-1600-100	36	81	1600
40-1800-100	36	82	1800
40-1800-100	36	73	1800
40-1800-100	36	84	1800
40-1800-120	36	82	1800
40-2000-100	36	85	2000
40-2000-120	36	86	2000
40-2200-120	36	90	2200



# Spiral spring cover SF

## For KGT 8010 For TGT-Dm 80

Spiral spring SF ID-Lv-BB	SD	AD	Lh
100-200-30	96	120	150
100-250-60	96	121	250
100-350-60	96	126	350
100-450-75	96	124	450
100-600-75	96	129	600
100-800-100	96	126	800
100-900-100	96	131	900
100-1000-100	96	132	1000
100-1100-120	96	129	1100
100-1200-100	96	137	1200
100-1300-100	96	140	1300
100-1500-100	96	146	1500
100-1700-120	96	147	1700
100-1800-150	96	151	1800
100-2000-150	96	157	2000
100-2500-150	96	164	2500
100-2800-180	96	168	2800
100-3000-150	96	188	3000
100-3500-200	96	174	2800

## For TGT-Dm 100

Spiral spring SF ID-Lv-BB	SD	AD	Lh
120-250-50	116	141	250
120-250-60	116	141	250
120-350-50	116	143	na
120-350-60	116	145	350
120-350-75	116	140	350
120-400-60	115	148	na
120-450-60	116	150	na
120-450-75	116	145	450
120-600-75	116	153	600
120-600-120	116	141	600
120-650-100	116	142	650
120-650-100	116	150	650
120-700-100	116	147	700
120-750-100	116	147	750
120-800-75	116	160	na
120-800-100	116	148	800
120-870-120	116	145	870
120-900-100	116	150	900
120-900-120	116	148	900

## For TGT-Dm 100

Spiral spring SF ID-Lv-BB	SD	AD	Lh
120-1100-120	116	153	1100
120-1200-150	116	155	1200
120-1300-120	116	158	1300
120-1300-150	116	156	1300
120-1300-180	116	156	1300
120-1500-120	116	162	1500
120-1500-150	116	163	na
120-1600-180	116	158	1600
120-1800-150	116	167	1800
120-1800-180	116	161	1800
120-2000-150	116	177	2000
120-2000-180	116	169	2000
120-2000-180	116	175	na
120-2200-180	116	174	2200
120-2200-200	116	173	2200
120-2200-200	116	165	1800
120-2400-200	116	170	2400
120-2600-200	116	174	2600
120-2800-200	116	177	2800

## For TGT-Dm 120

Spiral spring SF ID-Lv-BB	SD	AD	Lh
140-225-75	136	159	225
140-250-75	136	158	250
140-350-75	136	162	na
140-400-100	136	158	400
140-450-75	136	165	450
140-600-75	136	166	600
140-700-120	136	170	700
140-800-100	136	177	800
140-950-100	136	180	950
140-1000-120	136	192	750
140-1300-150	136	187	na
140-1500-200	136	173	1500
140-1700-200	136	184	na
140-1800-180	136	188	1800
140-1900-200	136	185	na
140-2000-200	136	193	2000
140-2100-180	136	190	2100
140-2400-180	136	200	2100
140-2500-200	136	197	na

## Ordering code spiral spring cover

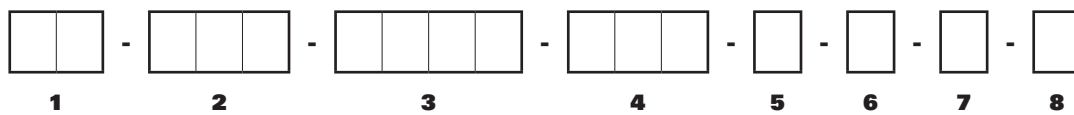

No.	Designation	Code	Description
1	Product abbreviation	<b>SF</b>	
2	ID in [mm]		Inside diameter of the spiral spring +1 mm
3	Largest length Lh/Lv in [mm]		Maximum extension length
4	BB / L <sub>min</sub> in [mm]		Width of band, corresponds to L <sub>min</sub>
5	Installation position	<b>H</b>	Horizontal
		<b>V</b>	Vertical
6	Material	<b>B</b>	Standard spring in blued spring steel
		<b>S</b>	Version in rustproof stainless steel
7	Accessories (If using mounting flanges the possible spindle diameter SD is reduced by 6 mm)	<b>0</b>	Without mounting flange
		<b>1</b>	With mounting flange outside (inside diameter +4 mm of outer diameter OD of spiral spring)
		<b>2</b>	With mounting flange inside (inside diameter -2 mm of inner diameter ID of spiral spring)
		<b>3</b>	With mounting flange inside/outside
8	Special requirements for mounting flange	<b>0</b>	None
		<b>1</b>	According to specification, description or drawing

## Lubricants

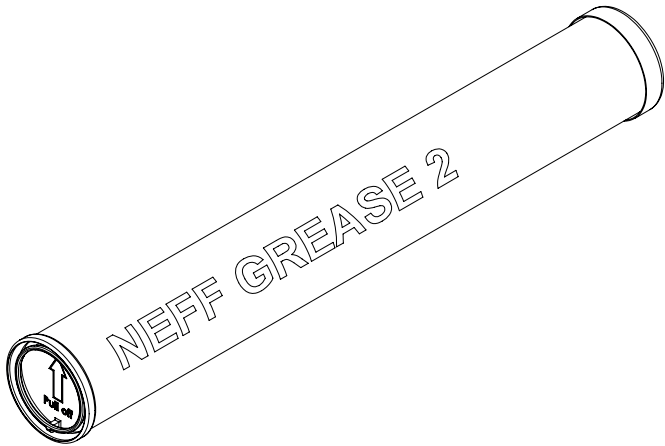

### **NEFF-Grease 2**

Neff Grease 2 was specially developed for use in highly-stressed trapezoidal screw drives, sliding screw drives and worm gear drives.

The heavy-duty grease was specially developed for high surface pressure and has outstanding temperature stability

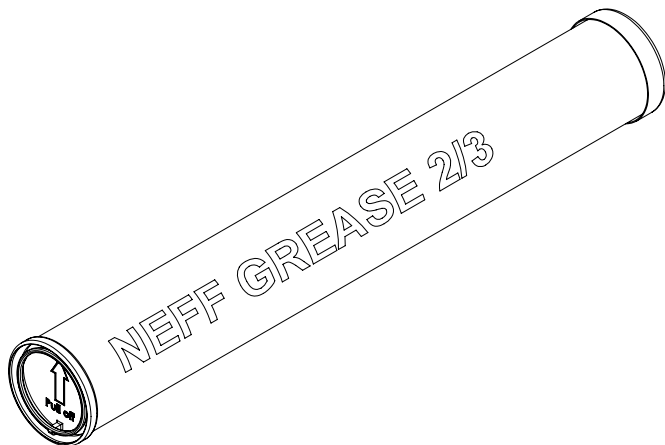

### **NEFF-Grease 2/3**

Neff Grease 2/3 was specially developed for use with highly-stressed ball screw drives.

The strongly adhering synthetic grease containing Teflon has very good temperature stability and can withstand high loads and vibrations.

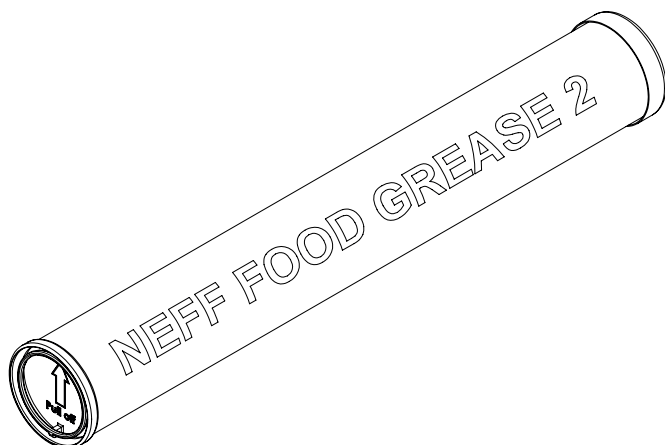

### **NEFF-Food Grease 2**

NEFF Food Grease 2 was specially developed for the requirements of the food industry. The grease meets the requirements of DIN V 10517. Suitable for use in applications with occasional food contact (class NSF-H1).

# NEFF Lubricant dispenser

The NEFF Lube 1 automatic lubricant dispenser is screwed directly onto the lubrication point. It operates independently and is activated when setting the running time. The lubricant level is always visible in the transparent window.

Readjustment during operation is possible.

The shelf life of the lubricant dispenser expires after 2 years.  
The NEFF Lube 1 lubricant dispenser is available in 4 sizes:

Size	Contents	Length L	Connection	Grease types	Grease delivery per day	Dispensing period
NEFF LUB 1-30	30ml	43mm	R ¼ inch	All standard NEFF Grease types	0.08–8.3 ml	1-12 month
NEFF LUB 1-60	60ml	62mm				
NEFF LUB 1-125	125ml	100mm				
NEFF LUB 1-250	250ml	192mm				

When ordering in conjunction with a ball screw or trapezoidal screw drive, please indicate special requirements of the nut in the ordering code.

Caution: When the lubricant dispenser is mounted the overall height of the NEFF LUB 1 is increased by about 25 mm due to the connecting/adaptor piece

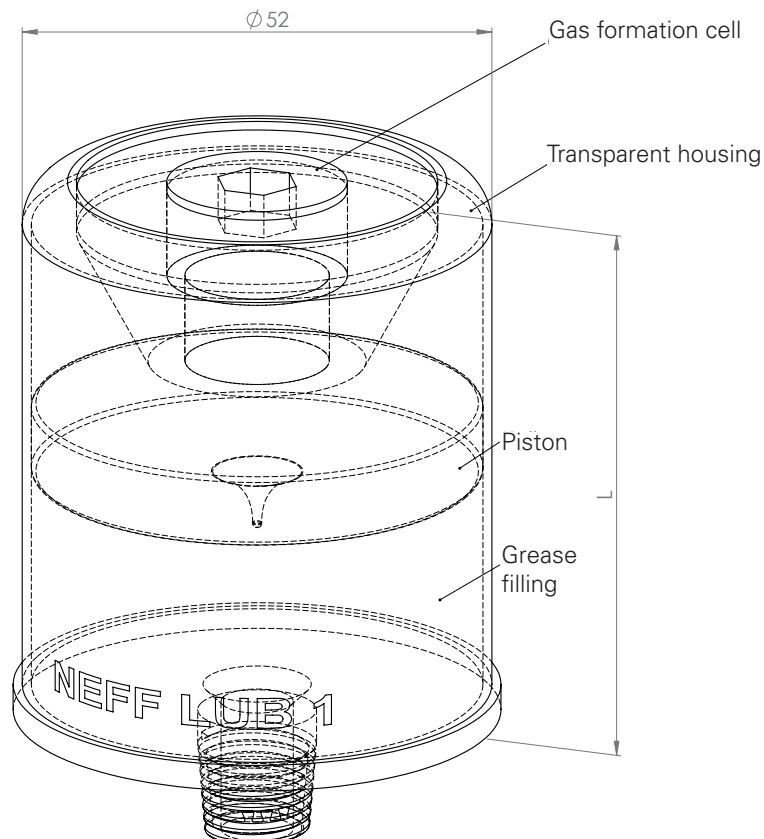

# Installation and maintenance

## Trapezoidal screw drives TGT

### Installation

Trapezoidal screw drives must be aligned carefully during installation – if suitable measuring equipment is not available, the screw drive should be turned through its entire length by hand before the drive unit is attached.

Variations in the amount of force required and/or marks on the external diameter of the spindle indicate alignment errors between the spindle axis and guide. In this case, the relevant mounting bolts should first be loosened and the screw drive should be turned through by hand. If the amount of force required is now constant throughout, the appropriate components should be aligned, otherwise the alignment error should be localised by loosening further mounting bolts.

### Cover

By virtue of their design, trapezoidal screw drives are less sensitive to dirt than ball screw drives, particularly at low speeds (manual operation). Nevertheless motion drives, especially with plastic nuts, require protection against dirt in the same way as ball screw drives.

## Lubrication

### Oil lubrication

Used only in special cases for trapezoidal screw drives.

### Grease lubrication

The usual lubrication method for trapezoidal screw drives. Lubrication intervals are governed by operating conditions; it is advisable to clean the spindle before greasing, especially by using high-performance lubricating machines.

Type of grease: ball bearing grease without solid lubricant. Parts ref. Neff Grease 2

### Operating temperature

This depends on the type of nut used, the lubrication conditions and the user's requirements. Please consult us in the case of temperatures above 100 °C (plastic nuts 70 °C).

### Wear

This can be checked manually: the nut should be replaced if the axial backlash with a single-start screw drive is more than 1/4 of the pitch.

## Ball screw drives KGT

### Installation

Ball screw drives are precision machine components; their installation requires specialist knowledge and suitable measuring equipment. Due to the low friction alignment errors can generally not be felt when the screw drive is turned by hand. Radial or eccentric forces must be taken up by external guides. Ball screw drives can absorb only axial forces. To avoid damage to the ball screw drive, limit switches and end stops must be installed in the machine.

### Cover

Dirt that occurs during installation should be removed with paraffin, oil or petroleum ether. Cold cleaners and paint solvents are not permitted. Ball screw drives must be protected against dust, swarf, etc. even if equipped with wipers. Possible protective measures include:

- Bellows (suitable only for vertical installation without additional guide).
- Spiral spring cover.
- Telescopic tubes or sleeves (these take up a lot of axial space).

## Lubrication

Proper lubrication is important for the achievement of the calculated service life of a ball screw drive, to prevent excessive warming and to ensure smooth, quiet running. The same lubricants are used for the KGT ball screw drives as for roller bearings.

### Oil-mist lubrication

In the case of central lubrication with oil mist, note that only ball screw nuts without wipers may be used.

### Oil lubrication

Die zugeführte Ölmenge sollte die Austragsverluste an den Abstreifern nicht überschreiten. (Sonst Öllumlaufschmierung).  
Ölarten: Viskosität 25 bis 100 mm<sup>2</sup>/s bei 100 °C.

### Grease lubrication

Add grease corresponding to the volume lost via the wipers (under normal operating conditions, it is sufficient to add grease every 200 to 300 hours). Experience shows that single lifetime lubrication is not sufficient because of the seepage of grease.

### Grease type:

Roller bearing grease with no solid lubricant content. The first fill takes place at the supplier's with roller bearing grease. We recommend Neff Gear Grease 2/3 in the case of high mechanical stresses.

### Operating temperature

The permissible operating temperature range for ball screw drives is between –30 °C and +80 °C, up to +110 °C for brief periods. A precondition for this is correct lubrication. The torque may increase by a factor of up to 10 at temperatures below –20 °C.

**The range includes a total of 11 worm gear screw jack models in two series: M 0 - M 5 with lifting capacities from 2.5 kN to 100 kN and J 1 - J 5 with static lifting capacities from 150 kN to 500 kN.**

### **Stroke speed**

#### **Transmission Ratio H (high speed)**

Worm gear screw jacks with trapezoidal-threaded spindle produce a stroke of 1 mm for each full revolution of the worm shaft. Accordingly the linear speed is 1500 mm per min at 1500 rpm. Worm gear screw jacks with a ball screw achieve 6000 mm/min, depending on size and pitch.

#### **Transmission Ratio L (low speed)**

Worm gear screw jacks with trapezoidal-threaded spindle produce a stroke of 0.25 mm for each full revolution of the worm shaft. Accordingly the linear speed is 375 mm per min at 1500 rpm.

Please note that higher speeds of travel can be achieved by using spindles with larger thread pitches or multi-start threads.

The worm gear screw jack's maximum drive speed of 3000 rpm must not be exceeded.

The higher efficiency of the ball screw drive also permits a longer duty cycle.

### **Tolerances and backlash**

- The gearbox housings are machined on the six mounting sides. The tolerances conform to DIN ISO 2768-mH
- The axial backlash of the jack screw under alternating load is as follows:
  - Trapezoidal-threaded spindles: up to 0.4 mm (to DIN 103)
  - Ball screws: 0.07 mm
- The lateral backlash between the outside diameter of the spindle and the guide diameter is 0.2 mm.
- The backlash in the worm gears is  $\pm 4^\circ$  for transmission ratio L and  $\pm 1^\circ$  for transmission ratio H based on the drive shaft.
- Trapezoidal-threaded spindles are manufactured to a straightness of 0.3 – 1.5 mm/m, ball screws to a straightness of 0.02 mm/m over a length of 1000 mm and to the following pitch accuracies:
  - M 0 – M 5: 0.05 mm/300 mm length
  - J 1 – J 5: 0.2 mm/300 mm length.

### **Lateral forces on the screw jack.**

Lateral forces can also be absorbed by our screw jacks. Please contact us.

## **Worm Gear Screw Jacks M/J**

### **Self-locking**

The self-locking function depends on a variety of parameters:

- High pitches
- Different worm gear transmission ratios
- Lubrication
- Friction parameters
- Environmental influences, such as high or low temperatures, vibrations, etc.
- The mounting position

Versions with ball screw and TGS/KGS with high pitches are therefore not self-locking. Suitable brakes or braking motors must therefore be used in such cases. Self-locking is only conditionally available for smaller pitches (single-start). Self-locking in individual cases on enquiry

### **Version N**

The lifting spindle is driven by a nut thread in the worm gear via the worm shaft. Protection against twisting is achieved by the on-site fastening of the spindle.

### **Version VK**

The lifting spindle is driven by a nut thread in the worm gear via the worm shaft. Protection against twisting is achieved by a square protective tube on the gear side.

### **Version VP**

The lifting spindle is driven by a nut thread in the worm gear via the worm shaft. Protection against twisting is achieved by a feather key in the bearing cover of the gearbox and a milled groove in the spindle.

### **Version R**

The lifting spindle is made to rotate by the worm shaft via the worm gear with a feather key connection to the spindle. The rotary motion of the spindle is converted into a linear motion by the on-site anti-twist securing of the travelling nut.

### **Anti-unscrewing device A**

The anti-unscrewing device prevents the spindle from screwing out of the gearbox. It is standard equipment in the ball screw versions N and V and is available as an option in worm gear screw jacks with trapezoidal-threaded spindles.

The anti-unscrewing device cannot be used as a fixed stop.

### **Special versions**

In addition to the extensive standard range, NEFF can also supply anticlockwise, multi-start and special material worm gear screw jacks on enquiry.

# General technical data

## Trapezoidal-thread spindle

		M 0	M 1	M 2	M 3	M 4	M 5	J 1	J 2	J 3	J 4	J 5
Maximum lifting force [kN] <sup>1)</sup>		2.5	5	10	25	50	100	150	200	250	350	500
Diameter and pitch [mm]		14 x 4	18 x 4	20 x 4	30 x 6	40 x 7	55 x 9	60 x 9	70 x 10	80 x 10	100 x 10	120 x 14
Stroke per revolution of the drive shaft [mm]	Transmission ratio. H <sup>2)</sup>	1	1	1	1	1	1	1	1	1	1	1
	Transmission ratio. L <sup>2)</sup>	0.25	0.25	0.25	0.25	0.25	0.25	0.25	0.25	0.25	0.25	0.25
Transmission ratio.	Transmission ratio. H <sup>2)</sup>	4:1	4:1	4:1	6:1	7:1	9:1	9:1	10:1	10:1	10:1	14:1
	Transmission ratio. L <sup>2)</sup>	16:1	16:1	16:1	24:1	28:1	36:1	36:1	40:1	40:1	40:1	56:1
Efficiency [%] <sup>3)</sup>	Transmission ratio. H <sup>2)</sup>	35	31	29	29	26	24	23	22	20	19	19
	Transmission ratio. L <sup>2)</sup>	27	25	23	23	21	19	18	17	15	15	15
Weight [kg] (without stroke)		0.6	1.2	2.1	6	17	32	41	57	57	85	160
Weight [kg per 100 mm stroke]		0.1	0.26	0.42	1.14	1.67	3.04	3.1	4.45	6.13	7.9	11.5
Idling torque [Nm]	H	0.02	0.04	0.11	0.15	0.35	0.84	0.88	1.28	1.32	1.62	1.98
	L	0.016	0.03	0.10	0.12	0.25	0.51	0.57	0.92	0.97	1.10	1.42
Housing material		G – AL up to M3					GGG – 40					

## Ball screw spindle

		M 0	M 1	M 2	M 3	M 4		M 5	J 3	
Maximum lifting force [kN] <sup>1)</sup>		2	5	10	12.5	22	42	65	78	
Diameter and pitch [mm]		1205	1605	2005	2505	4005	4010	5010	8010	
Stroke per revolution of the drive shaft [mm]	Transmission ratio. H <sup>2)</sup>	1.25	1.25	1.25	0.83	0.71	1.43	1.1	1	
	Transmission ratio. L <sup>2)</sup>	0.31	0.31	0.31	0.21	0.18	0.36	0.28	0.25	
Transmission ratio.	Transmission ratio. H <sup>2)</sup>	4:1	4:1	4:1	6:1	7:1		9:1	10:1	
	Transmission ratio. L <sup>2)</sup>	16:1	16:1	16:1	24:1	28:1		36:1	40:1	
Efficiency [%] <sup>3)</sup>	Transmission ratio. H <sup>2)</sup>	60	57	56	55	53	56	47	45	
	Transmission ratio. L <sup>2)</sup>	48	46	44	43	43	45	37	34	
Weight [kg] (without stroke)		0.6	1.3	2.3	7	19		35	63	
Weight [kg per 100 mm stroke]		0.09	0.26	0.42	1.14	1.67		3.04	6.13	
Idling torque [Nm]	H	0.02	0.04	0.11	0.15	0.35		0.84	1.32	
	L	0.016	0.03	0.10	0.12	0.25		0.51	0.97	
Housing material		G – AL up to M3					GGG – 40			

<sup>1)</sup> Dependent on stroke speed, duty cycle, etc.

<sup>2)</sup> H = high travel speed,

L = low travel speed

<sup>3)</sup> The specified efficiency values are average values



# Dimensions, version N

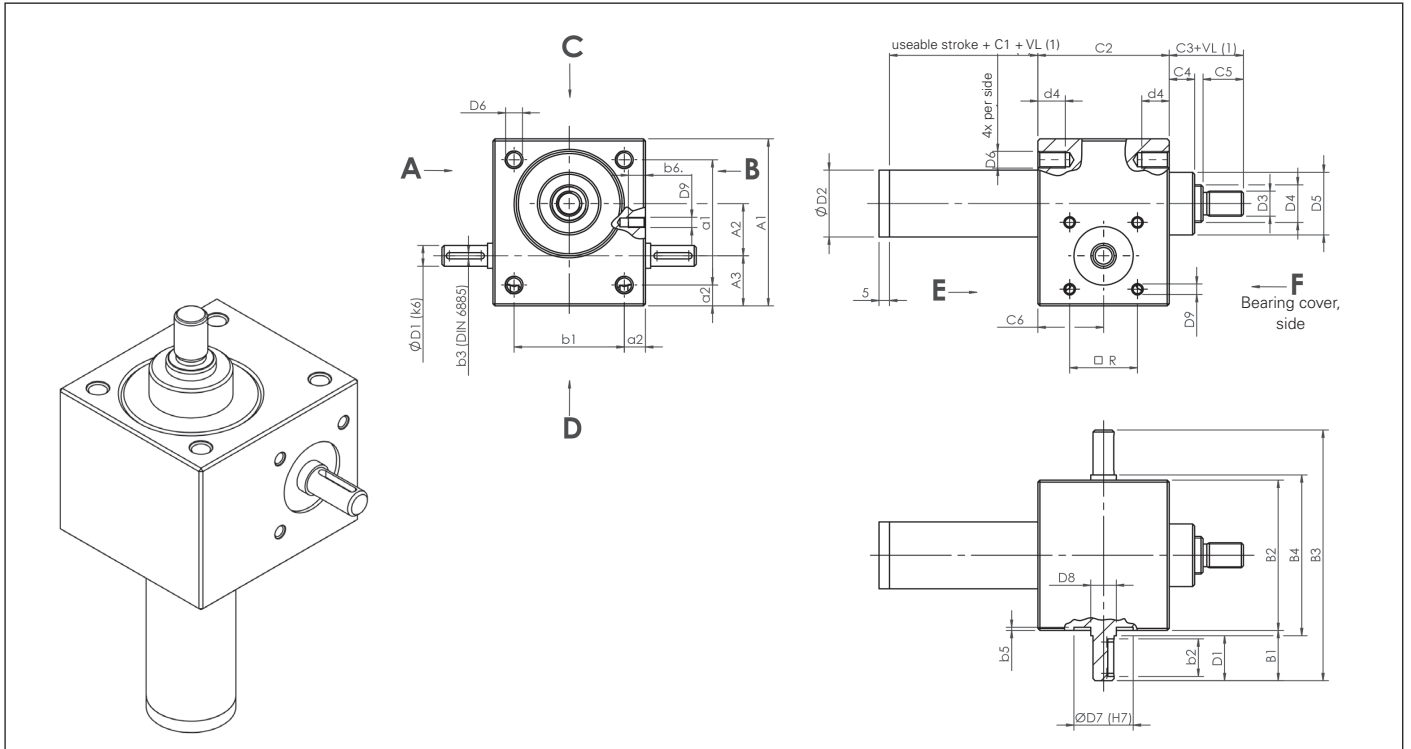

Size	Dimensions [mm]																
	A <sub>1</sub>	A <sub>2</sub>	A <sub>3</sub>	a <sub>1</sub>	a <sub>2</sub>	B <sub>1</sub>	B <sub>2</sub>	B <sub>3</sub>	B <sub>4</sub>	b <sub>1</sub>	b <sub>2</sub>	b <sub>3</sub>	b <sub>5</sub>	C <sub>1</sub> TR <sup>(2)</sup>	C <sub>1</sub> KGT/AS <sup>(3)</sup>	C <sub>2</sub>	C <sub>3</sub>
M 0	60	20	18	48	6	21	50	92	52	38	14	3	1.5	20	50	50	27
M 1	80	25	24	60	10	24	72	120	77	52	18	3	1.5	20	50	62	35
M 2	100	32	28	78	11	27.5	85	140	90	63	20	5	1.5	30	60	75	45
M 3	130	45	31	106	12	45	105	195	110	81	36	5	2	35	70	82	50
M 4	180	63	39	150	15	47.5	145	240	150	115	36	6	2	40	90	117	65
M 5	200	71	46	166	17	67.5	165	300	170	131	56	8	2.5	55	100	160	95
J 1	210	71	49	170	20	65	195	325	200	155	56	8	8	55	100	175	95
J 2	240	80	60	190	25	67.5	220	355	225	170	56	8	8	60	110	165	110
J 3 (M6)	240	80	60	190	25	67.5	220	355	225	170	56	8	8	60	110	165	110
J 4 (M7)	290	100	65	230	30	65	250	380	255	190	56	10	8	65	150	220	140
J 5 (M8)	360	135	75	290	35	100	300	500	305	230	90	14	8	100	145	266	200

Size	Dimensions [mm]														
	C <sub>4</sub>	C <sub>5</sub>	C <sub>6</sub>	D <sub>1k6</sub>	D <sub>2</sub>	D <sub>3</sub>	d <sub>4</sub>	D <sub>4</sub> Tr	D <sub>4</sub> KGT	D <sub>5</sub>	D <sub>6</sub>	D <sub>7</sub> <sup>H7</sup>	D <sub>8</sub>	D <sub>9</sub> x b <sub>6</sub>	TK □ R
M 0	12	12	25	9 x 20	28	M8	12	Tr14 x 4	1205	26	M6	22	10	(M5 x 6)*	24
M 1	12	19	31	10 x 21.5	32	M12	13	Tr18 x 4	1605	30	M8	32	12	M5 x 6	32
M 2	18	20	37.5	14 x 25	40	M14	15	Tr20 x 4	2005	38.7	M8	35	15	M6 x 10	35
M 3	23	22	41	16 x 42.5	50	M20	15	Tr30 x 6	2505	46	M10	40	17	M8 x 10	44
M 4	32	29	58.5	20 x 45	65	M30	16	Tr40 x 7	4005/4010	60	M12	52	25	M10 x 14	55
M 5	40	48	80	25 x 65	90	M36	30	Tr55 x 9	5010	85	M20	62	28	M12 x 16	70
J 1	40	48	87.5	25 x 62.5	95	M48 x 2	40	Tr60 x 9	–	90	M24	72	28	M12 x 16	70
J 2	40	58	82.5	30 x 65	110	M56 x 2	45	Tr70 x 10	–	105	M30	80	32	M12 x 18	(80)
J 3 (M6)	40	58	82.5	30 x 65	125	M64 x 3	45	Tr80 x 10	8010	120	M30	80	32	M12 x 18	(80)
J 4 (M7)	50	78	110	35 x 62.5	150	M72 x 3	54	Tr100 x 10	–	145	M36	85	40	M16 x 30	(80)
J 5 (M8)	60	118	133	48 x 97.5	180	M100 x 3	80	Tr120 x 14	–	170	M42	90	50	M16 x 40	(115)

\* Tapped bore for motor adaptor flange on attachment side A and B standard only centralised. Tapped bore on enquiry.  
Note: subject to technical changes.

(1) VL: Spindle extension

(2) Mass C1 for screw jacks with trapezoidal screw drive

(3) Mass C1 for screw jacks with ball screw drive or securing against hollowing

# Dimensions, version VK

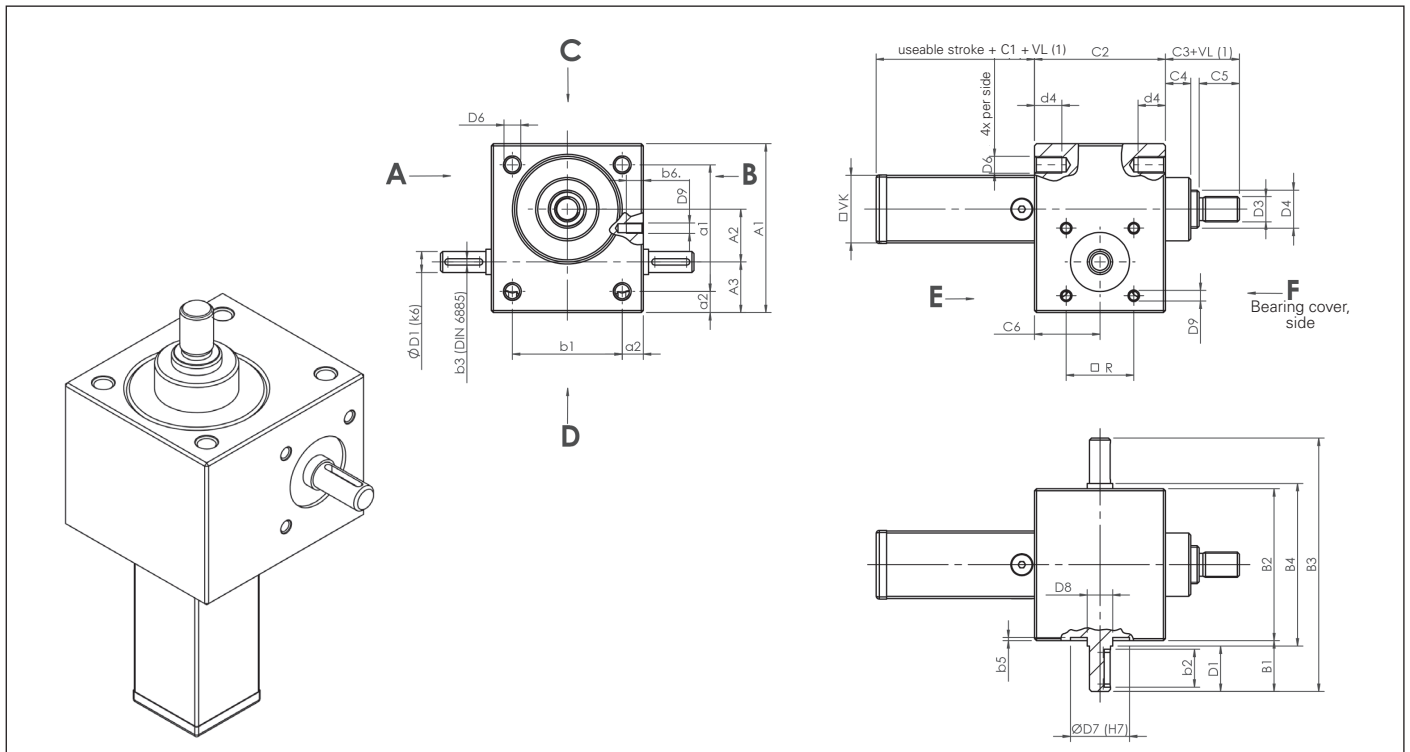

Size	Dimensions [mm]																
	A <sub>1</sub>	A <sub>2</sub>	A <sub>3</sub>	a <sub>1</sub>	a <sub>2</sub>	B <sub>1</sub>	B <sub>2</sub>	B <sub>3</sub>	B <sub>4</sub>	b <sub>1</sub>	b <sub>2</sub>	b <sub>3</sub>	b <sub>5</sub>	C <sub>1,TR</sub> <sup>(2)</sup>	C <sub>1,KGT/AS</sub> <sup>(3)</sup>	C <sub>2</sub>	C <sub>3</sub>
M 0	60	20	18	48	6	21	50	92	52	38	14	3	1.5	20	50	50	27
M 1	80	25	24	60	10	24	72	120	77	52	18	3	1.5	20	50	62	35
M 2	100	32	28	78	11	27.5	85	140	90	63	20	5	1.5	30	60	75	45
M 3	130	45	31	106	12	45	105	195	110	81	36	5	2	35	70	82	50
M 4	180	63	39	150	15	47.5	145	240	150	115	36	6	2	40	90	117	65
M 5	200	71	46	166	17	67.5	165	300	170	131	56	8	2.5	55	100	160	95
J 1	210	71	49	170	20	65	195	325	200	155	56	8	8	55	100	175	95
J 2	240	80	60	190	25	67.5	220	355	225	170	56	8	8	60	110	165	110
J 3 (M6)	240	80	60	190	25	67.5	220	355	225	170	56	8	8	60	110	165	110
J 4 (M7)	290	100	65	230	30	65	250	380	255	190	56	10	8	65	150	220	140
J 5 (M8)	360	135	75	290	35	100	300	500	305	230	90	14	8	100	145	266	200

Size	Dimensions [mm]														
	C <sub>4</sub>	C <sub>5</sub>	C <sub>6</sub>	D <sub>1k6</sub>	D <sub>3</sub>	d <sub>4</sub>	D <sub>4,Tr</sub>	D <sub>4,KGT</sub>	D <sub>5</sub>	D <sub>6</sub>	D <sub>7</sub> <sup>H7</sup>	D <sub>8</sub>	D <sub>9</sub> x b <sub>6</sub> *	TK □ R	V-KGT
M 0	12	12	25	9 x 20	M8	12	Tr14 x 4	1205	26	M6	22	10	(M5 x 6)*	24	30 x 30
M 1	12	19	31	10 x 21.5	M12	13	Tr18 x 4	1605	30	M8	32	12	M5 x 6	32	35 x 35
M 2	18	20	37.5	14 x 25	M14	15	Tr20 x 4	2005	38.7	M8	35	15	M6 x 10	35	40 x 40
M 3	23	22	41	16 x 42.5	M20	15	Tr30 x 6	2505	46	M10	40	17	M8 x 10	44	50 x 50
M 4	32	29	58.5	20 x 45	M30	16	Tr40 x 7	4005/4010	60	M12	52	25	M10 x 14	55	70 x 70
M 5	40	48	80	25 x 65	M36	30	Tr55 x 9	5010	85	M20	62	28	M12 x 16	70	90 x 90
J 1	40	48	87.5	25 x 62.5	M48 x 2	40	Tr60 x 9	-	90	M24	72	28	M12 x 16	70	90 x 90
J 2	40	58	82.5	30 x 65	M56 x 2	45	Tr70 x 10	-	105	M30	80	32	M12 x 18	(80)	110 x 110
J 3 (M6)	40	58	82.5	30 x 65	M64 x 3	45	Tr80 x 10	8010	120	M30	80	32	M12 x 18	(80)	125 x 125
J 4 (M7)	50	78	110	35 x 62.5	M72 x 3	54	Tr100 x 10	-	145	M36	85	40	M16 x 30	(80)	150 x 150
J 5 (M8)	60	118	133	48 x 97.5	M100 x 3	80	Tr120 x 14	-	170	M42	90	50	M16 x 40	(115)	180 x 180

\* Tapped bore for motor adaptor flange on attachment side A and B standard only centralised. Tapped bore on enquiry.  
Note: subject to technical changes.

(1) VL: Spindle extension  
(2) Mass C1 for screw jacks with trapezoidal screw drive  
(3) Mass C1 for screw jacks with ball screw drive or securing against hollowing

# Dimensions, version VP

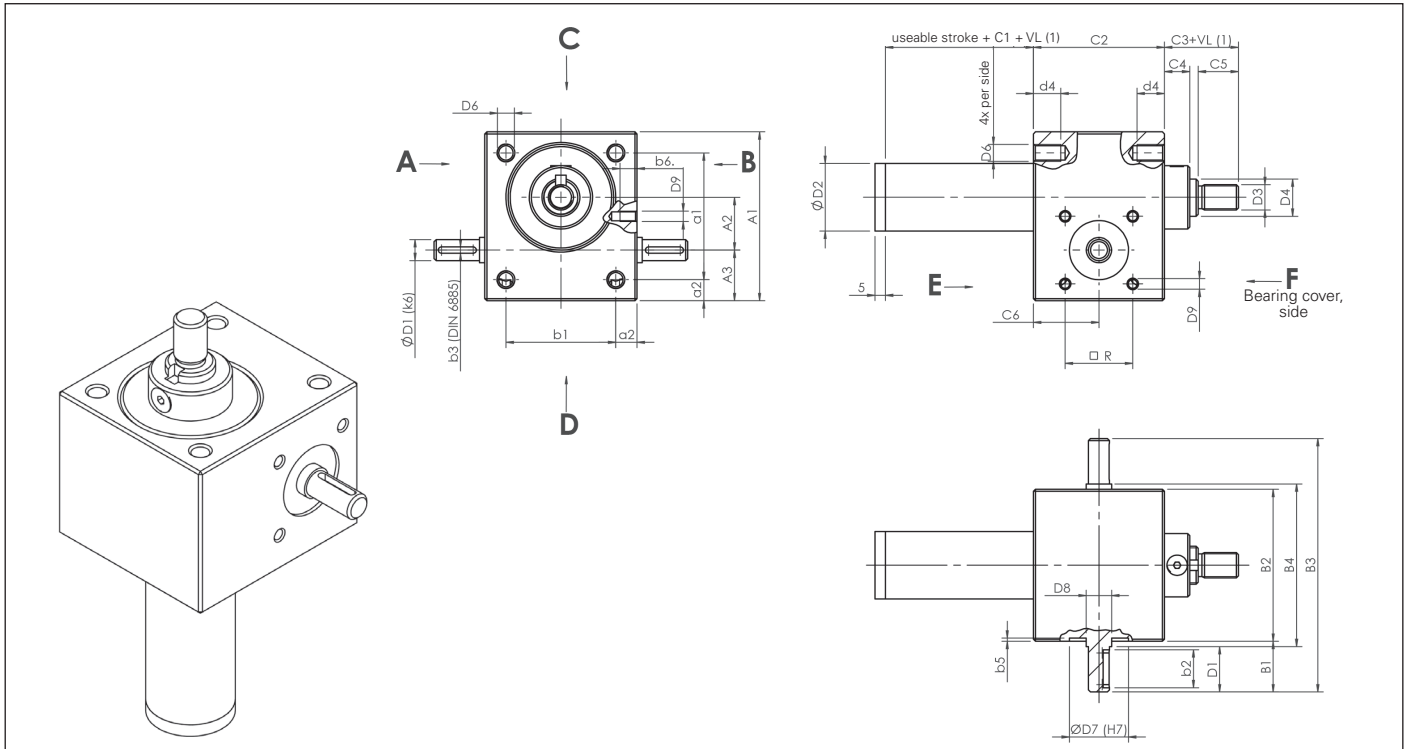

Size	Dimensions [mm]																
	A <sub>1</sub>	A <sub>2</sub>	A <sub>3</sub>	a <sub>1</sub>	a <sub>2</sub>	B <sub>1</sub>	B <sub>2</sub>	B <sub>3</sub>	B <sub>4</sub>	b <sub>1</sub>	b <sub>2</sub>	b <sub>3</sub>	b <sub>5</sub>	C <sub>1</sub> TR <sup>(2)</sup>	C <sub>1</sub> KGT/AS <sup>(3)</sup>	C <sub>2</sub>	C <sub>3</sub>
M 0	60	20	18	48	6	21	50	92	52	38	14	3	1.5	20	50	50	27
M 1	80	25	24	60	10	24	72	120	77	52	18	3	1.5	20	50	62	35
M 2	100	32	28	78	11	27.5	85	140	90	63	20	5	1.5	30	60	75	45
M 3	130	45	31	106	12	45	105	195	110	81	36	5	2	35	70	82	50
M 4	180	63	39	150	15	47.5	145	240	150	115	36	6	2	40	90	117	65
M 5	200	71	46	166	17	67.5	165	300	170	131	56	8	2.5	55	100	160	95
J 1	210	71	49	170	20	65	195	325	200	155	56	8	8	55	100	175	95
J 2	240	80	60	190	25	67.5	220	355	225	170	56	8	8	60	110	165	110
J 3	240	80	60	190	25	67.5	220	355	225	170	56	8	8	60	110	165	110
J 4	290	100	65	230	30	65	250	380	255	190	56	10	8	65	150	220	140
J 5	360	135	75	290	35	100	300	500	305	230	90	14	8	100	145	266	200

Size	Dimensions [mm]														
	C <sub>4</sub>	C <sub>5</sub>	C <sub>6</sub>	D <sub>1k6</sub>	D <sub>2</sub>	D <sub>3</sub>	d <sub>4</sub>	D <sub>4</sub> Tr	D <sub>4</sub> KGT	D <sub>5</sub>	D <sub>6</sub>	D <sub>7</sub> <sup>H7</sup>	D <sub>8</sub>	D <sub>9</sub> x b <sub>6</sub>	TK □ R
M 0	12	12	25	9 x 20	28	M8	12	Tr14 x 4	1205	26	M6	22	10	(M5 x 6)*	24
M 1	12	19	31	10 x 21.5	32	M12	13	Tr18 x 4	1605	30	M8	32	12	M5 x 6	32
M 2	18	20	37.5	14 x 25	40	M14	15	Tr20 x 4	2005	38.7	M8	35	15	M6 x 10	35
M 3	23	22	41	16 x 42.5	50	M20	15	Tr30 x 6	2505	46	M10	40	17	M8 x 10	44
M 4	32	29	58.5	20 x 45	65	M30	16	Tr40 x 7	4005/4010	60	M12	52	25	M10 x 14	55
M 5	40	48	80	25 x 65	90	M36	30	Tr55 x 9	5010	85	M20	62	28	M12 x 16	70
J 1	40	48	87.5	25 x 62.5	95	M48 x 2	40	Tr60 x 9	—	90	M24	72	28	M12 x 16	70
J 2	40	58	82.5	30 x 65	110	M56 x 2	45	Tr70 x 10	—	105	M30	80	32	M12 x 18	(80)
J 3 (M6)	40	58	82.5	30 x 65	125	M64 x 3	45	Tr80 x 10	8010	120	M30	80	32	M12 x 18	(80)
J 4 (M7)	50	78	110	35 x 62.5	150	M72 x 3	54	Tr100 x 10	—	145	M36	85	40	M16 x 30	(80)
J 5 (M8)	60	118	133	48 x 97.5	180	M100 x 3	80	Tr120 x 14	—	170	M42	90	50	M16 x 40	(115)

\* Tapped bore for motor adaptor flange on attachment side A and B standard only centralised. Tapped bore on enquiry.  
Note: subject to technical changes.

(1) VL: Spindle extension

(2) Mass C1 for screw jacks with trapezoidal screw drive

(3) Mass C1 for screw jacks with ball screw drive or securing against hollowing

# Dimensions, version R

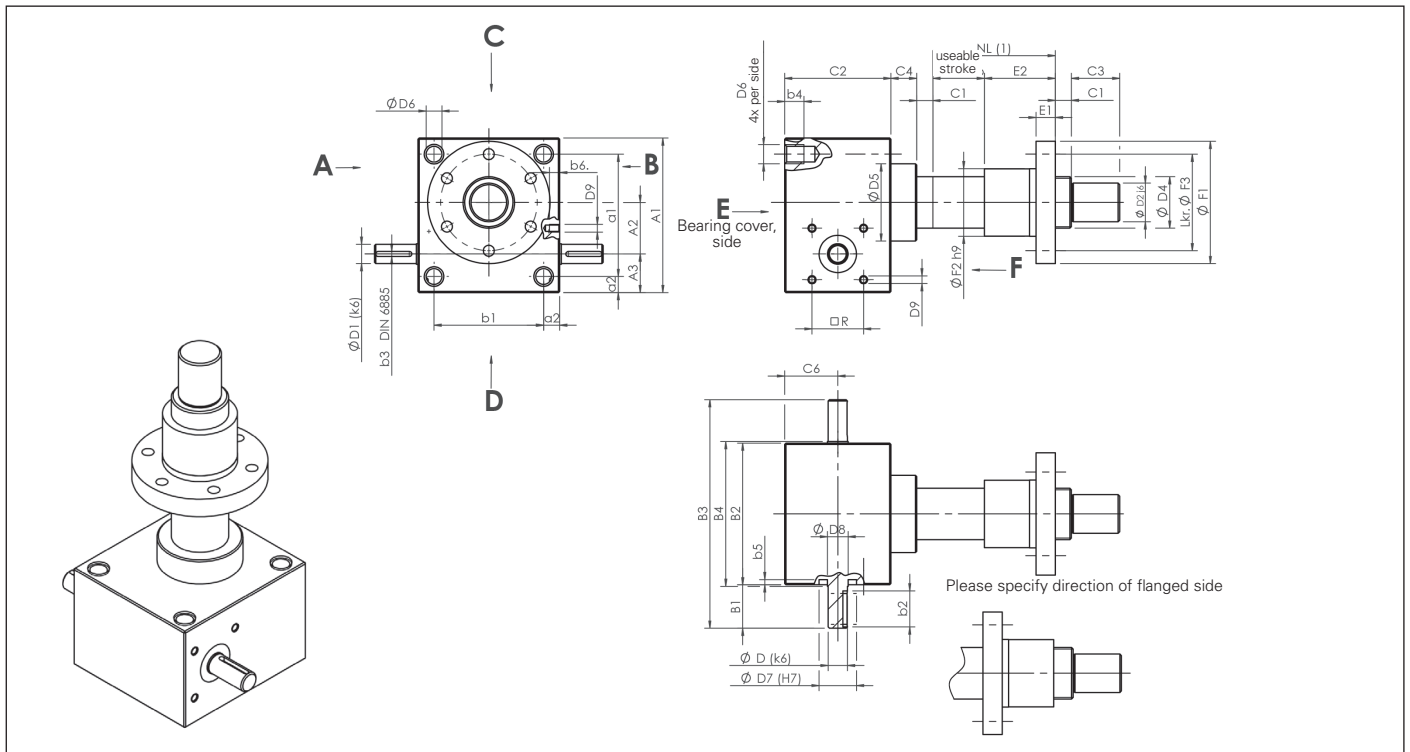

Size	Dimensions [mm]																		
	A <sub>1</sub>	A <sub>2</sub>	A <sub>3</sub>	a <sub>1</sub>	a <sub>2</sub>	B <sub>1</sub>	B <sub>2</sub>	B <sub>3</sub>	B <sub>4</sub>	b <sub>1</sub>	b <sub>2</sub>	b <sub>3</sub>	b <sub>4</sub>	b <sub>5</sub>	C <sub>1</sub>	C <sub>2</sub>	C <sub>3</sub>	C <sub>4</sub>	C <sub>6</sub>
M 0	60	20	18	48	6	21	50	92	52	38	14	3	12	1.5	10	50	12	12	25
M 1	80	25	24	60	10	24	72	120	77	52	18	3	13	1.5	12	62	15	12	31
M 2	100	32	28	78	11	27.5	85	140	90	63	20	5	15	1.5	15	75	20	18	37.5
M 3	130	45	31	106	12	45	105	195	110	81	36	5	15	2	20	82	25	23	41
M 4	180	63	39	150	15	47.5	145	240	150	115	36	6	16	2	25	117	30	32	58.5
M 5	200	71	46	166	17	67.5	165	300	170	131	56	8	30	2.5	25	160	45	40	80
J 1	210	71	49	170	20	65	195	325	200	155	56	8	40	8	25	175	55	40	87.5
J 2	240	80	60	190	25	67.5	220	355	225	170	56	8	45	8	25	165	70	40	82.5
J 3	240	80	60	190	25	67.5	220	355	225	170	56	8	45	8	25	165	75	40	82.5
J 4	290	100	65	230	30	65	250	380	255	190	56	10	54	8	25	220	100	50	110
J 5	360	135	75	290	35	100	300	500	305	230	90	14	80	8	30	266	120	60	133

Size	Dimensions [mm]																
	D <sub>1k6</sub>	D <sub>216</sub>	D <sub>4TR</sub>	D <sub>4KGT</sub>	D <sub>5</sub>	D <sub>6</sub>	D <sub>7H7</sub>	D <sub>8</sub>	D <sub>9 x b<sub>6</sub></sub>	□ R	E <sub>1</sub>	E <sub>2</sub>	F <sub>1</sub>	F <sub>2</sub>	F <sub>3</sub>	F <sub>4</sub>	
M 0	9 x 20	8	Tr14 x 4	1205	26	M6	22	10	M5 x 6*	24	12	35	48	28	38	6	
M 1	10 x 21.5	12	Tr18 x 4	1605	30	M8	32	12	(M5 x 6)*	32	12/12	44/44	48/48	28/28	38/38	6/6	
M 2	14 x 25	15	Tr20 x 4	2005	36.1	M8	32	15	M6 x 10	35	12/12	44/44	55/55	32/32	45/45	7/7	
M 3	16 x 42.5	20	Tr30 x 6	2505	46	M10	40	17	M8 x 10	44	14/14	46/46	62/62	38/38	50/50	7/7	
M 4	20 x 45	25	Tr40 x 7	4005/4010	60	M12	52	25	M10 x 14	55	16/16	73/59	95/80	63/53	78/68	9/7	
M 5	25 x 65	40	Tr55 x 9	5010	85	M20	62	28	M12 x 16	70	18/18	97/97	110/110	72/72	90/90	11/11	
J 1	25 x 62.5	45	Tr60 x 9	-	90	M24	72	28	M12 x 16	70	20	99	125	85	105	11	
J 2	30 x 65	55	Tr70 x 10	-	105.2	M30	80	32	M12 x 18	(80)	30	100	180	95	140	17	
J 3 (M 6)	30 x 65	60	Tr80 x 10	8010	120	M30	80	32	M12 x 18	(80)	30/22	110/101	190/145	105/105	150/125	17/14	
J 4 (M 7)	35 x 62.5	80	Tr100 x 10	-	145	M36	85	40	M16 x 30	(80)	35	130	240	130	185	25	
J 5 (M 8)	48 x 97.5	95	Tr120 x 14	-	170	M42	90	50	M16 x 40	(115)	40	160	300	160	230	28	

\* Tapped bore for motor adaptor flange on attachment side A and B standard only centralised. Tapped bore on enquiry.

Note: subject to technical changes.

(1) NL: usable stroke length

# Dimensions

Version N/VK/VP with limit switch attachment

## Limit switch with roller plunger:

Actuating cam 30° according to DIN 69639

- Minimum actuation stroke: 2.6 mm +/- 0.5mm
- Differential stroke: 0.85 mm +/- 0.25mm
- Minimum switch-on force: 1 N
- Start-up speed: 0.001 to 0.1 m/s
- Connection: 5-core (brown/blue: normally open; black/black: normally closed; green/yellow: earth conductor)
- Switching capacity: NFC 63146

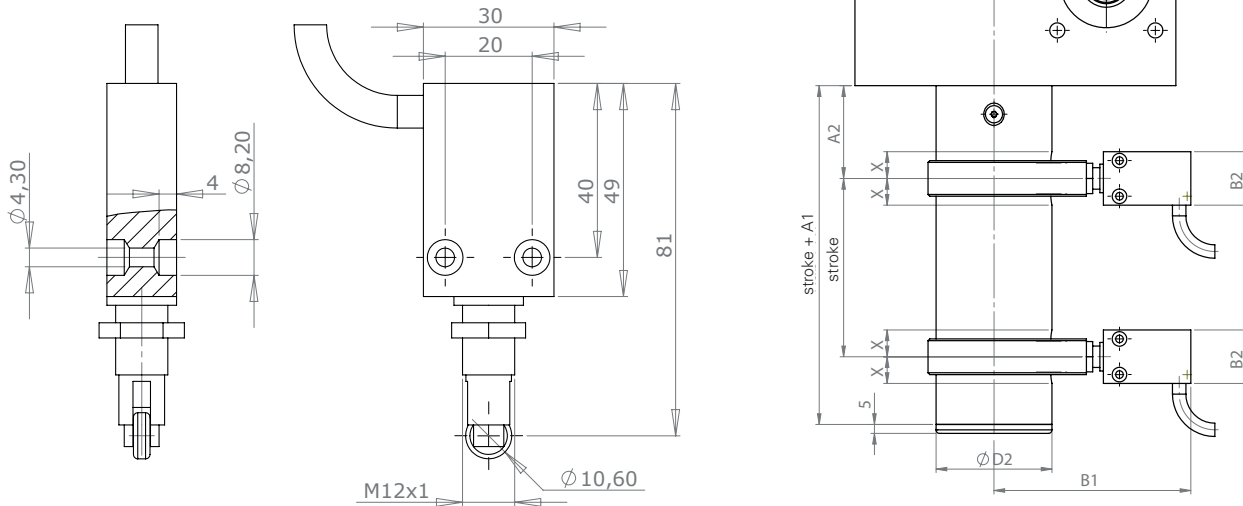

Size	Dimensions [mm]						
	A <sub>1</sub>	A <sub>2</sub>	B <sub>1</sub>	B <sub>2</sub>	M	X	Ø D2
M0	65	27	94	30	M12x1	±10	28
M1	65	27	96	30	M12x1	±10	32
M2	65	32	100	30	M12x1	±10	40
M3	75	41	105	30	M12x1	±10	50
M4	90	52	113	30	M12x1	±10	65
M5	100	60	125	30	M12x1	±10	90
J1	100	60	125	30	M12x1	±10	95
J2	on enquiry						
J3							
J4							
J5							









# Ordering code

## Worm gear screw jacks

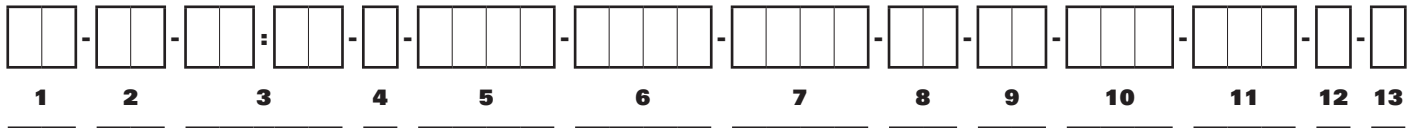

No.	Designation	Code	Description
1	Size	<b>M1, M2, ...</b>	
		<b>J1, J2, ...</b>	
2	Design	<b>N</b>	Lifting spindle
		<b>VP</b>	Lifting spindle, protected against twisting by feather key
		<b>VK</b>	Lifting spindle, protected against twisting by square tube
		<b>R</b>	Rotating spindle
3	Transmission ratio	<b>4:1 / 16:1</b>	For M0, M1, M2
		<b>6:1 / 24:1</b>	For M3
		<b>7:1 / 28:1</b>	For M4
		<b>9:1 / 36:1</b>	For M5 and J1
		<b>10:1 / 40:1</b>	For J2, J3, J4
4	Type of spindle	<b>T</b>	Trapezoidal screw drive
		<b>K</b>	Ball screw drive
5	Spindle dimension		e.g. 2005 = diameter 20 mm, pitch 5 mm
6	Stroke in [mm]		Specification of the stroke length
7	Attached part for version N/VK/VP		Spindle extension VL, Usable stroke length NL, e.g. due to block dimension bellows, mounting situation. See product drawings at page 57-60.
	Usable stroke length NL for version R		
8	Spindle end	<b>M</b>	Metric threaded stem
		<b>A</b>	End with chamfer
		<b>S</b>	Custom (according to specification, description or drawing)
		<b>Z</b>	Centric stem (standard for version R)
9	Attached part for version N/VK/VP	<b>O</b>	None
		<b>BP</b>	With fastening plate mounted
		<b>GA</b>	With spherical bearing mounted
		<b>GK</b>	With fork end mounted
	Nut type for version R	<b>HG</b>	With high-performance fork end mounted
		<b>F-D</b>	Flanged nut according to DIN 69051 (flange direction to housing)
		<b>F-N</b>	Flanged nut according to NEFF-Norm (flange direction to housing)
		<b>D-F</b>	Flanged nut according to DIN 69051 (flange direction to screw end)
10	Spindle cover	<b>N-F</b>	Flanged nut according to NEFF-Norm (flange direction to screw end)
		<b>O</b>	None
		<b>FB</b>	With bellows
		<b>SF</b>	With spiral spring cover
11	Anti-unscrewing device	<b>O</b>	None
		<b>AS</b>	With (installed as standard in KGT)
12	Shaft end	<b>O</b>	On both sides A+B (Standard)
		<b>A</b>	Shaft end on Side A
		<b>B</b>	Shaft end on side B
13	Special requirements	<b>O</b>	None
		<b>1</b>	According to specification, description or drawing

# High-speed screw jacks G1-G3

## High Speed Screw Jack G1-G3

NEFF high speed screw jacks supplement our offer of worm gear screw jacks. They are more efficient and may be used in a broader field of applications. They may be used in a medium load range (12.3 kN-117 kN), with a high lifting speed and longer operating time.

All high speed screw jacks are equipped with hardened, sharpened and spiral-toothed bevel gear transmissions. Therefore, they attain high lifting speeds and improved efficiency.

The models N, V and R are available in three sizes with 2:1 and 3:1 transmissions. With ball screws, high speed screw jacks become even

more dynamic. All high speed screw jacks work in all installation positions. Due to their cubic casing they can be mounted flexibly.

By using ball screws the high-speed screw jacks achieve even better performance values. All high-speed screw jacks are functional in every installation position and can be mounted flexibly thanks to the cubic form of the housing.

According to the customer's request they are delivered with up to four drive shafts. Lifting assemblies with several high speed screw jacks do not therefore require additional bevel gears.

Technical data - type N:							
Size <sup>7)</sup>	G1-N-TGS 24x5	G1-N-KGS 2505	G2-N-TGS 40x7	G2-N-KGS 3210	G2-N-KGS 4005	G3-N-TGS 60x9	G3-N-KGS 6310
Max. stroke and drag force in [kN]	20.6	12.3	44.5	33.4	23.8	117	76
Stroke per full turn of the screw shaft, ratio 2:1 in [mm]	2.5	2.5	3.5	5	2.5	4.5	5
Stroke per full turn of the screw shaft, ratio 3:1 in [mm]	1.6	1.6	2.3	3.33	1.6	3	3.33
Max. stroke speed in m/min ratio 2:1, 3000/min	<sup>1)</sup>	7.5	<sup>2)</sup>	15	7.5	<sup>3)</sup>	15
Max. stroke speed in m/min ratio 3:1, 3000/min	<sup>4)</sup>	5.01	<sup>5)</sup>	10	4.99	<sup>6)</sup>	9.99
Efficiency	0.45	0.75	0.4	0.75	0.75	0.35	0.75
Max. moment of a torque on the screw shaft in [Nm]	50	50	175	175	175	1600	1600

Technical data - type R:							
Size <sup>7)</sup>	G1-R-TGS 24x5	G1-R-KGS 2505	G2-R-TGS 40x7	G2-R-KGS 3210	G2-R-KGS 4005	G3-R-TGS 60x9	G3-R-KGS 6310
Max. stroke and drag force in [kN]	19.6	12.3	56.5	33.4	23.8	117	76
Stroke per full turn of the screw shaft, ratio 2:1 in [mm] <sup>8)</sup>	2.5	2.5	3.5	5	2.5	4.5	5
Stroke per full turn of the screw shaft, ratio 3:1 in [mm] <sup>8)</sup>	1.6	1.6	2.3	3.33	1.6	3	3.33
Max. stroke speed in m/min ratio 2:1, 3000/min	<sup>1)</sup>	7.5	<sup>2)</sup>	15	7.5	<sup>3)</sup>	15
Max. stroke speed in m/min ratio 3:1, 3000/min	<sup>4)</sup>	5.01	<sup>5)</sup>	10	4.99	<sup>6)</sup>	9.99
Efficiency	0.45	0.75	0.4	0.75	0.75	0.35	0.75
Max. moment of a torque on the screw shaft in [Nm]	50	50	175	175	175	1600	1600

1) max. permissible screw revolution speed (max. 4,55m/min at 1820/min)

2) max. permissible screw revolution speed (max. 1,82m/min at 520/min)

3) max. permissible screw revolution speed (max. 1,44m/min at 320/min)

4) max. permissible screw revolution speed (max. 4,55m/min at 2730/min)

5) max. permissible screw revolution speed (max. 1,82m/min at 780/min)

6) max. permissible screw revolution speed (max. 1,44m/min at 460/min)

7) **all screw sizes with other threads in stock**

8) ratio 1:1 on request

# High-speed screw jacks

Dimensions - type R

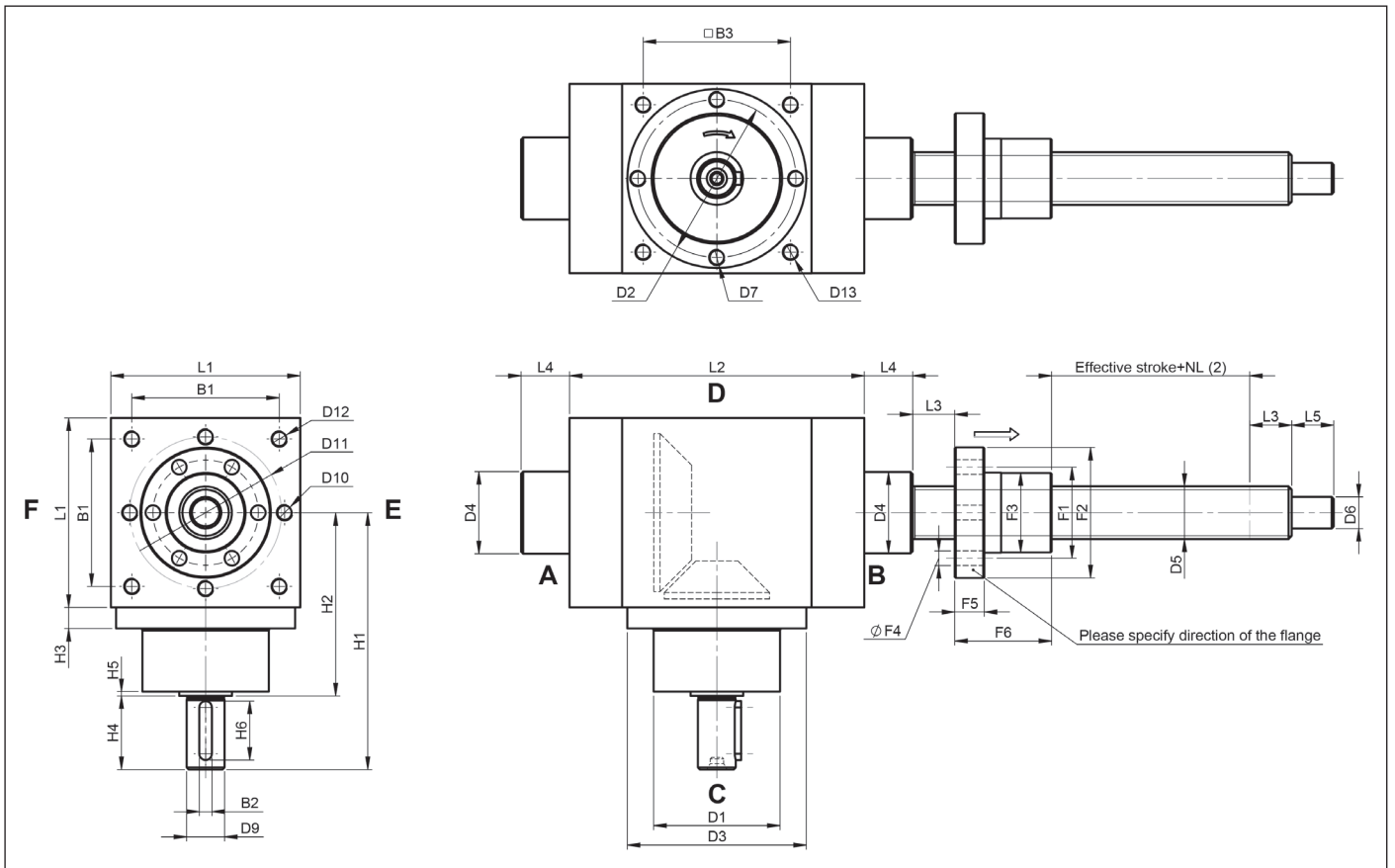

Size	L1	L2	L3	L4	L5	B1	B2	B3	H1	H2	H3	H4	H5	H6	D1	D2	D3 h7
G1	90	140	20	23	25	-	6	-	122	87	10	35	2	25	60	75	90
G2	140	190	25	32	30	113	10	110	180	130	13	50	2	45	95	-	135
G3	230	295	40	40	55	-	16/12 <sup>1</sup>	180	305/310 <sup>1</sup>	215/230 <sup>1</sup>	17	90/80 <sup>1</sup>	7.5	80/63 <sup>1</sup>	150/120 <sup>1</sup>	-	225

Size	D4	D5	D6 j6	D7	D9 j6	D10	D11	D12	D13	F1	F2	F3	F4	F5	F6
G1	39	T24x5/K2505	20	M8	18/12 <sup>1</sup>	M10	72	-	-	50	62	38	7	14	46
G2	60	T40x7/K4005	25	-	32	-	-	M12	M10	68	80	53	7	16	59
G3	90	T60x9/K6310	45	-	55/40 <sup>1</sup>	M20	180	-	M16	105	125	85	11	20	99

1) First dimension for ratio 2:1, second dimension for ratio 3:1

2) NL: usable stroke length

# High-speed screw jacks G1

## Dimensions - type N/V

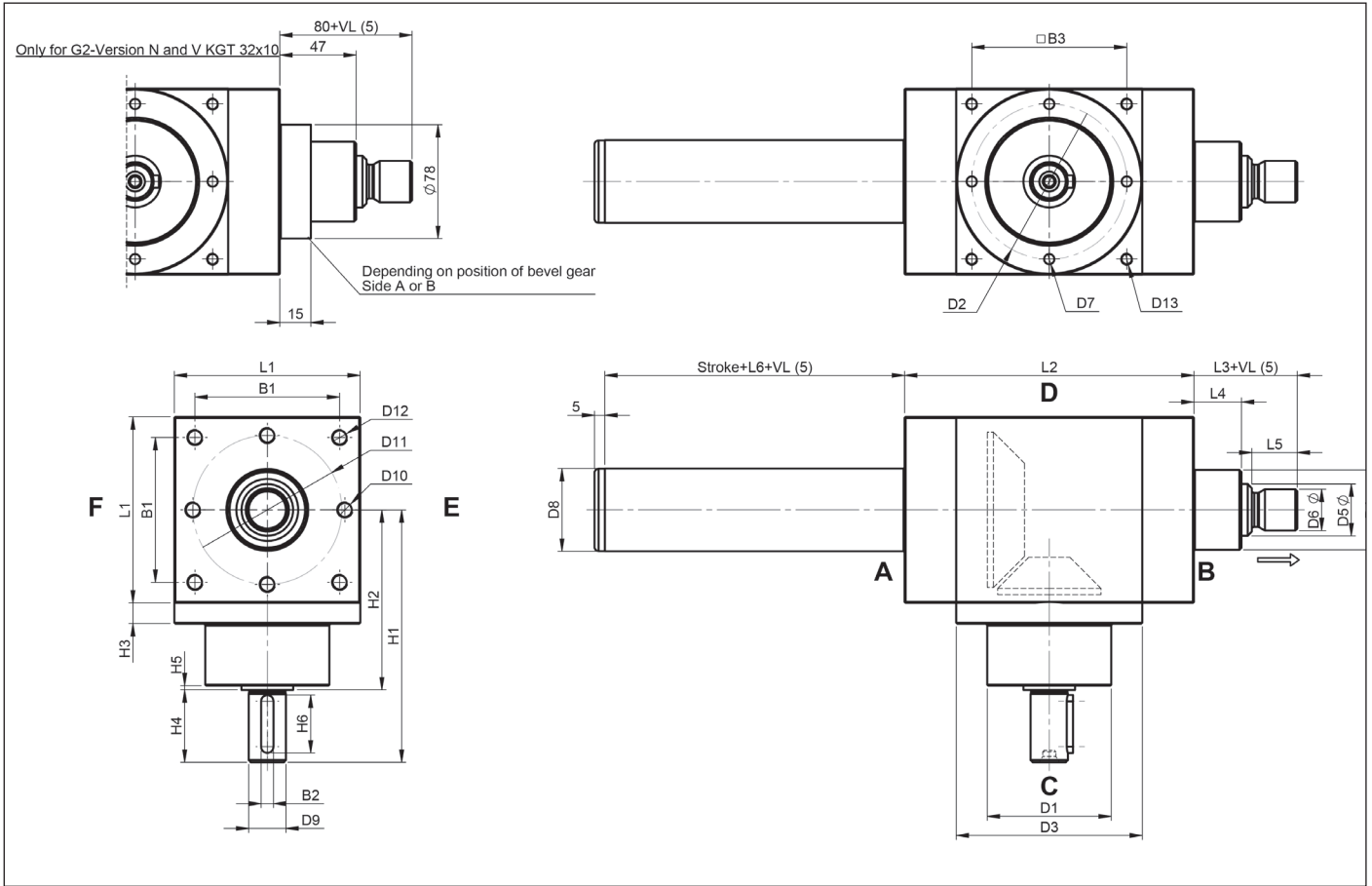

Size	L1	L2	L3	L4	L5	L6	B1	B2	B3	H1	H2	H3	H4	H5	H6	D1	D2	D3 h7
G1	90	140	50	23	22	35/70 <sup>4</sup>	-	6	-	122	87	10	35	2	25	60	75	90
G2	140	190	65	32	29	45/100 <sup>4</sup>	113	10	110	180	130	13	50	2	45	95	-	135
G3	230	295	95	40	48	60/110 <sup>4</sup>	-	16/12 <sup>1</sup>	180	305/310 <sup>1</sup>	215/230 <sup>1</sup>	17.5	90/80 <sup>1</sup>	2/3.5 <sup>1</sup>	80/63 <sup>1</sup>	150/120 <sup>1</sup>	-	225

Size	D4	D5	D6	D7	D8	D9 j6	D10	D11	D12	D13
G1	39	T24x5/K2505	M18/M20 <sup>3</sup>	M8	42/ 40 <sup>2</sup>	18/12 <sup>1</sup>	M10	72	-	-
G2	60	T40x7/K4005	M30/M20 <sup>3</sup>	-	65/ 65 <sup>2</sup>	32	-	-	M12	M10
G3	90	T60x9/K6310	M48x2 <sup>3</sup>	-	90/ 90 <sup>2</sup>	55/40 <sup>1</sup>	M20	180	-	M16

- 1) First dimension for ratio 2:1, second dimension for ratio 3:1
- 2) First dimension for Standard-Version N, second dimension for square-type tube Version V
- 3) First dimension for trapezoidal screw, second dimension for ball screw
- 4) Second dimension for stop collar or locking device
- 5) VL: spindle extension

- Service life over 500 hrs
- Service life 100-500 hrs
- only static permissible (service life less than 100 hrs)

## Performance table

### G1-N-KGS 2505

n [rpm]	Stroke speed [m/min]		F=15 [kN]				F=12.5 [kN]				F=10 [kN]				F=7.5 [kN]				F=5 [kN]				F=2.5 [kN]				F=1 [kN]			
			2:1		3:1		2:1		3:1		2:1		3:1		2:1		3:1		2:1		3:1		2:1		3:1		2:1		3:1	
	2:1	3:1	Nm	kW	Nm	kW	Nm	kW	Nm	kW	Nm	kW	Nm	kW	Nm	kW	Nm	kW	Nm	kW	Nm	kW	Nm	kW	Nm	kW	Nm	kW	Nm	kW
3000	7.50	5.00	9.758	3.1	6.8	2.1	8.431	2.6	5.9	1.9	7.1	2.2	5.1	1.6	5.7	1.8	4.3	1.4	4.5	1.4	3.4	1.1	3.1	1.0	2.5	0.8	2.3	0.7	2.0	0.6
2250	5.63	3.75	9.758	2.3	6.8	1.6	8.431	2.0	6.0	1.4	7.1	1.7	5.1	1.2	5.7	1.3	4.3	1.0	4.5	1.0	3.4	0.8	3.1	0.7	2.5	0.6	2.3	0.5	2.0	0.5
1500	3.75	2.50	9.758	1.5	6.8	1.1	8.431	1.3	6.0	0.9	7.1	1.1	5.1	0.8	5.7	0.9	4.3	0.7	4.5	0.7	3.4	0.5	3.1	0.5	2.5	0.4	2.3	0.4	2.0	0.3
1000	2.50	1.67	9.758	1.0	6.8	0.7	8.431	0.9	6.0	0.6	7.1	0.7	5.1	0.5	5.7	0.6	4.3	0.5	4.5	0.5	3.4	0.4	3.1	0.3	2.5	0.3	2.3	0.2	2.0	0.2
750	1.88	1.25	9.758	0.8	6.8	0.5	8.431	0.7	6.0	0.5	7.1	0.6	5.1	0.4	5.7	0.4	4.3	0.3	4.5	0.3	3.4	0.3	3.1	0.2	2.5	0.2	2.3	0.2	2.0	0.2
500	1.25	0.83	9.758	0.5	6.8	0.4	8.431	0.4	6.0	0.3	7.1	0.4	5.1	0.3	5.7	0.3	4.3	0.2	4.5	0.2	3.4	0.2	3.1	0.2	2.5	0.1	2.3	0.1	2.0	0.1
250	0.63	0.42	9.758	0.3	6.8	0.2	8.431	0.2	6.0	0.2	7.1	0.2	5.1	0.1	5.7	0.1	4.3	0.1	4.5	0.1	3.4	0.1	3.1	0.1	2.5	0.1	2.3	0.1	2.0	0.1

### G2-N-KGS 4005

n [rpm]	Stroke speed [m/min]		F=50 [kN]				F=30 [kN]				F=20 [kN]				F=15 [kN]				F=10 [kN]				F=5 [kN]				F=2.5 [kN]			
			2:1		3:1		2:1		3:1		2:1		3:1		2:1		3:1		2:1		3:1		2:1		3:1		2:1		3:1	
	2:1	3:1	Nm	kW	Nm	kW	Nm	kW	Nm	kW	Nm	kW	Nm	kW	Nm	kW	Nm	kW	Nm	kW	Nm	kW	Nm	kW	Nm	kW	Nm	kW	Nm	kW
3000	7.50	5.00	28.83	9.1	19	6.0	18.22	5.7	12	3.9	13	4.1	9	2.8	10	3.2	7.3	2.3	7.6	2.4	5.6	1.8	5	1.6	3.9	1.2	3.6	1.1	3	1.0
2250	5.63	3.75	28.83	6.8	19	4.5	18.22	4.3	12	2.9	13	3.0	9	2.1	10	2.4	7.3	1.7	7.6	1.8	5.6	1.3	5	1.2	3.9	0.9	3.6	0.9	3	0.7
1500	3.75	2.50	28.83	4.5	19	3.0	18.22	2.9	12	2.0	13	2.0	9	1.4	10	1.6	7.3	1.1	7.6	1.2	5.6	0.9	5	0.8	3.9	0.6	3.6	0.6	3	0.5
1000	2.50	1.67	28.83	3.0	19	2.0	18.22	1.9	12	1.3	13	1.4	9	0.9	10	1.1	7.3	0.8	7.6	0.8	5.6	0.6	5	0.5	3.9	0.4	3.6	0.4	3	0.3
750	1.88	1.25	28.83	2.3	19	1.5	18.22	1.4	12	1.0	13	1.0	9	0.7	10	0.8	7.3	0.6	7.6	0.6	5.6	0.4	5	0.4	3.9	0.3	3.6	0.3	3	0.2
500	1.25	0.83	28.83	1.5	19	1.0	18.22	1.0	12	0.7	13	0.7	9	0.5	10	0.5	7.3	0.4	7.6	0.4	5.6	0.3	5	0.3	3.9	0.2	3.6	0.2	3	0.1
250	0.63	0.42	28.83	0.8	19	0.5	18.22	0.5	12	0.3	13	0.3	9	0.2	10	0.3	7.3	0.2	7.6	0.2	5.6	0.1	5	0.1	3.9	0.1	3.6	0.1	3	0.1

### G3-N-KGS 6310

n [rpm]	Stroke speed [m/min]		F=90 [kN]				F=75 [kN]				F=50 [kN]				F=25 [kN]				F=10 [kN]				F=5 [kN]				F=2.5 [kN]			
			2:1		3:1		2:1		3:1		2:1		3:1		2:1		3:1		2:1		3:1		2:1		3:1		2:1		3:1	
	2:1	3:1	Nm	kW	Nm	kW	Nm	kW	Nm	kW	Nm	kW	Nm	kW	Nm	kW	Nm	kW	Nm	kW	Nm	kW	Nm	kW	Nm	kW	Nm	kW	Nm	kW
3000	15.00	10.00	99.89	31	68	21	83.98	26	57	18	57	18	40	12	31	9.7	22	6.9	15	4.7	11	3.6	9.7	3	7.8	2.5	7.1	2.2	6.1	1.9
2250	11.25	7.50	99.89	24	68	16	83.98	20	57	13	57	14	40	9.3	31	7.3	22	5.2	15	3.5	11	2.7	9.7	2.3	7.8	1.8	7.1	1.7	6.1	1.4
1500	7.50	5.00	99.89	16	68	11	83.98	13	57	9	57	9	40	6.2	31	4.9	22	3.5	15	2.4	11	1.8	9.7	1.5	7.8	1.2	7.1	1.1	6.1	1
1000	5.00	3.33	99.89	10	68	7.1	83.98	8.8	57	6	57	6	40	4.1	31	3.2	22	2.3	15	1.6	11	1.2	9.7	1	7.8	0.8	7.1	0.7	6.1	0.6
750	3.75	2.50	99.89	7.8	68	5.3	83.98	6.6	57	4.5	57	4.5	40	3.1	31	2.4	22	1.7	15	1.2	11	0.9	9.7	0.8	7.8	0.6	7.1	0.6	6.1	0.5
500	2.50	1.67	99.89	5.2	68	3.6	83.98	4.4	57	3	57	3	40	2.1	31	1.6	22	1.2	15	0.8	11	0.6	9.7	0.5	7.8	0.4	7.1	0.4	6.1	0.1
250	1.25	0.83	99.89	2.6	68	1.8	83.98	2.2	57	1.5	57	1.5	40	1	31	0.8	22	0.6	15	0.4	11	0.1	9.7	0.3	7.8	0.1	7.1	0.2	6.1	0.1

Note: values are valid at an ambient temperature of 20 °C  
 Tables for other spindle types on request.

# High-speed screw jacks G1

Operating time-Chart G1 at 1500/min  
and 20° ambient temperature

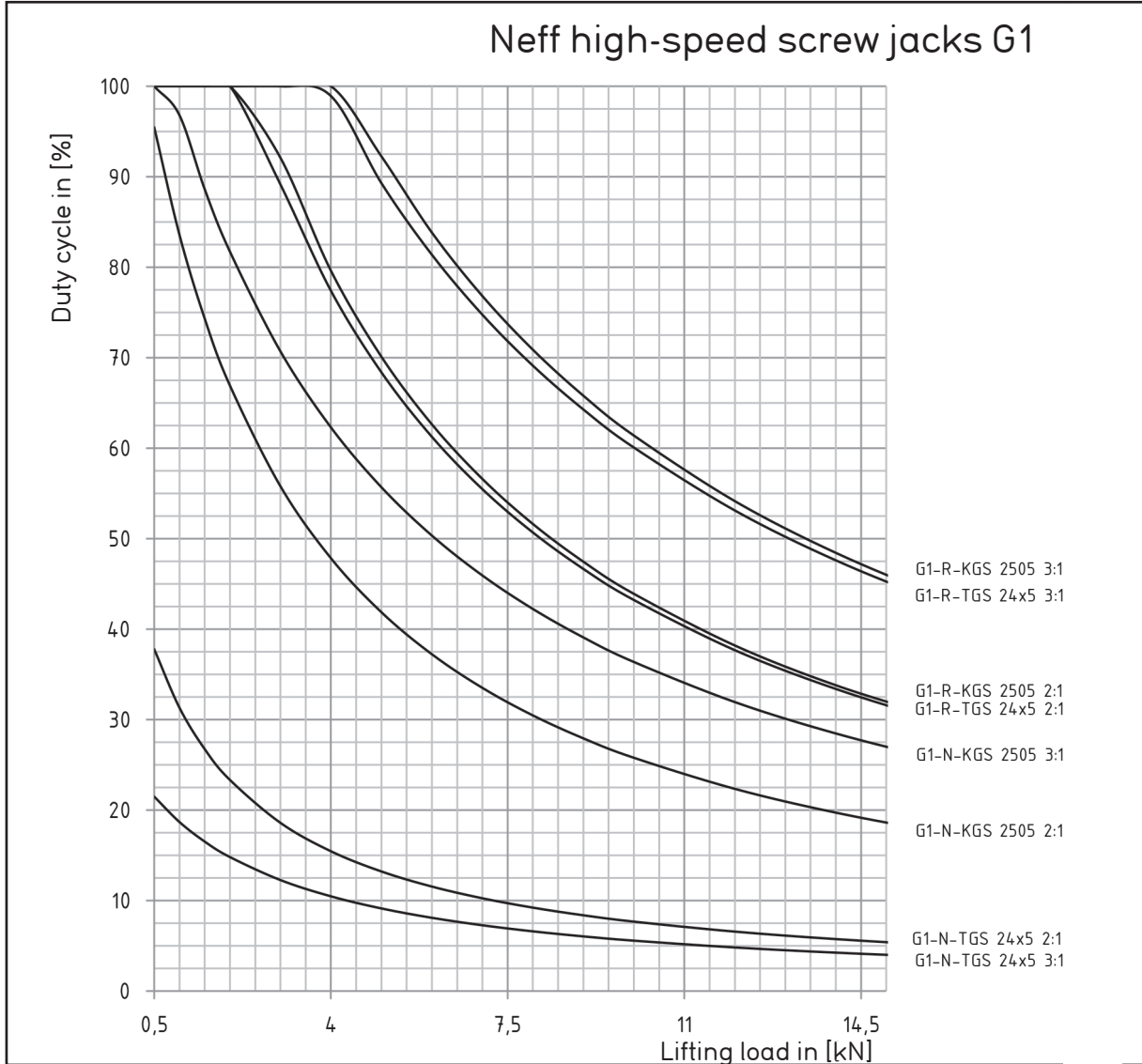

To calculate the Operating time  $ED_n/h$  for other speeds, multiply the Operating time in [%] with the speed-factor  $fn_{neff}$ :

$$ED_n/h \text{ in } [\%] = ED_h \times fn_{neff}$$

If different speeds determine the average of speed:

$$n_m = n_1 \times q_1 + n_2 \times q_2 + \dots + n_i \times q_i / 100$$

$n_1, n_2, \dots$  = Speed in [1/min] during the clearance

$q_1, q_2, \dots$  = Dues of load duration in [%]

$n_m$  = Average speed in [1/min]

speed	speed factor $fn_{neff}$
3000	0.5
2500	0.6
2000	0.75
1000	1.5
750	2
500	3
250	6

# High-speed screw jacks G2

**Operating time-Chart G2 at 1500/min  
and 20° ambient temperature**

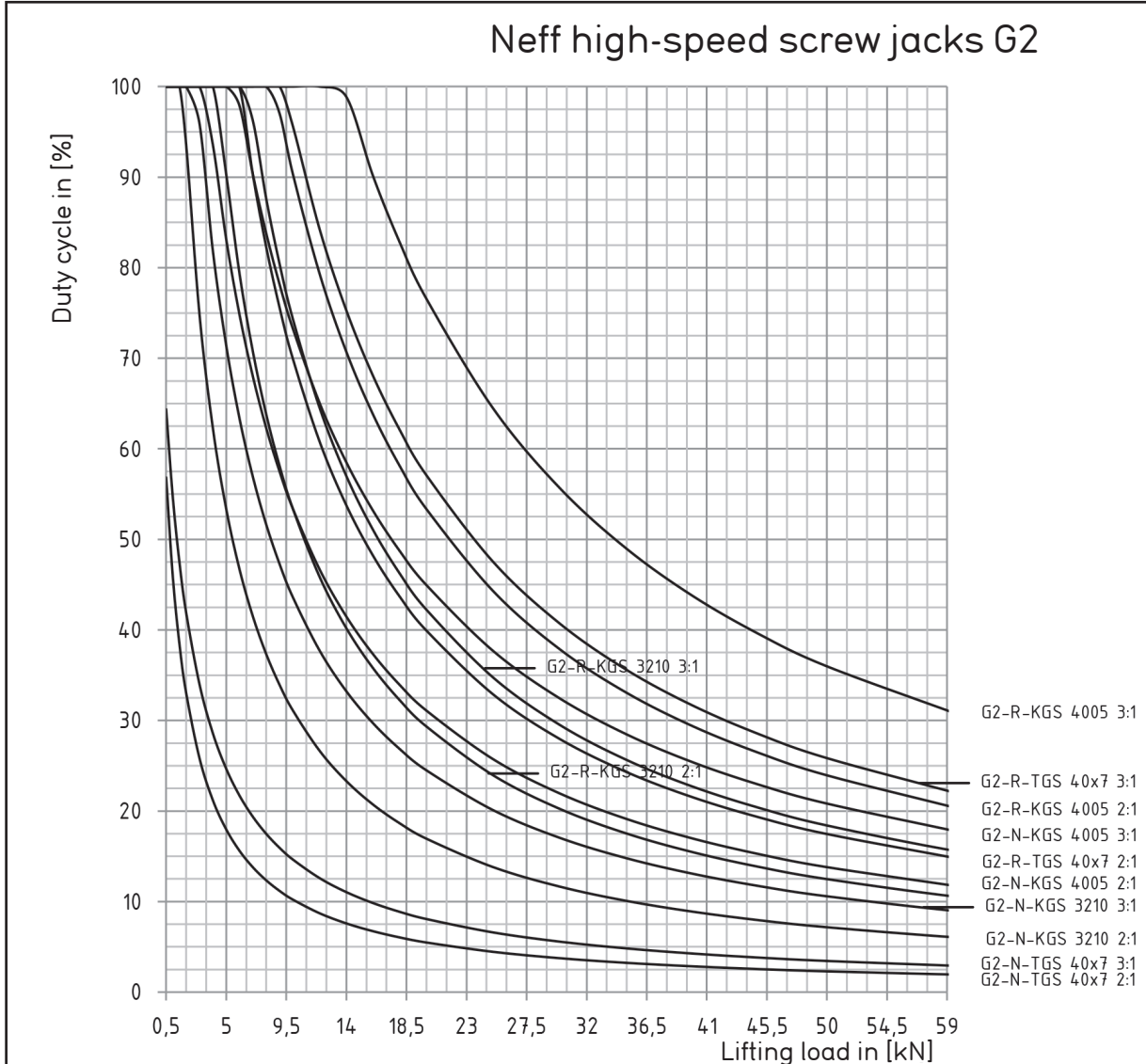

To calculate the Operating time  $ED_n/h$  for other speeds, multiply the Operating time in [%] with the speed-factor  $fn_{neff}$ :

$$ED_n/h \text{ in } [\%] = ED_d/h \times fn_{neff}$$

If different speeds determine the average of speed:

$$n_m = n_1 \times q_1 + n_2 \times q_2 + \dots + n_i \times q_i / 100$$

$n_1, n_2, \dots$  = Speed in [1/min] during the clearance

$q_1, q_2, \dots$  = Dues of load duration in [%]

$n_m$  = Average speed in [1/min]

speed	speed factor $fn_{neff}$
3000	0.5
2500	0.6
2000	0.75
1000	1.5
750	2
500	3
250	6

# High-speed screw jacks G3

Operating time-Chart G3 at 1500/min  
and 20° ambient temperature

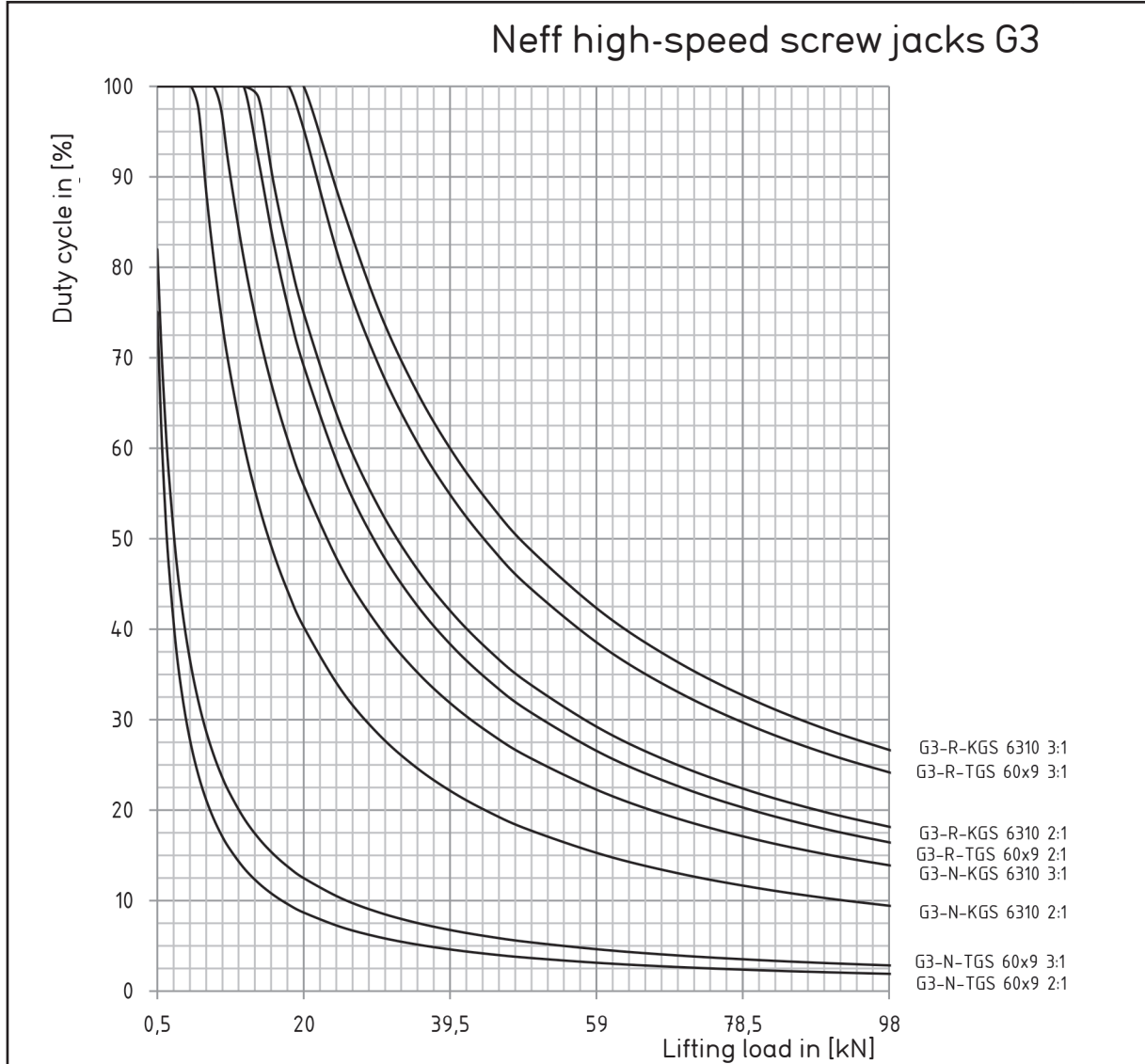

To calculate the Operating time  $ED_n/h$  for other speeds, multiply the Operating time in [%] with the speed-factor  $fn_{neff}$ :

$$ED_n/h \text{ in } [\%] = ED_q/h \times fn_{neff}$$

If different speeds determine the average of speed:

$$n_m = n_1 \times q_1 + n_2 \times q_2 + \dots + n_i \times q_i / 100$$

$n_1, n_2, \dots$  = Speed in [1/min] during the clearance

$q_1, q_2, \dots$  = Dues of load duration in [%]

$n_m$  = Average speed in [1/min]

speed	speed factor $fn_{neff}$
3000	0.5
2500	0.6
2000	0.75
1000	1.5
750	2
500	3
250	6



# Ordering code

## High Speed Screw Jacks

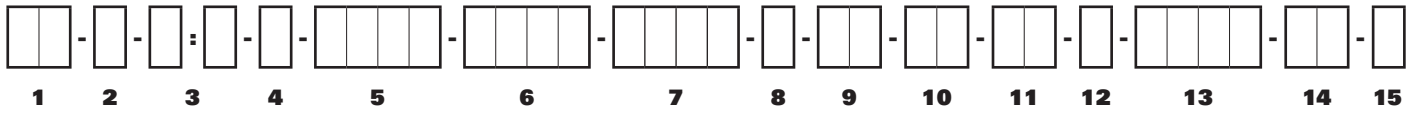

No.	Designation	Code	Description
<b>1</b>	Size	<b>G1, G2, G3</b>	
<b>2</b>	Design	<b>N</b>	Lifting spindle
		<b>V</b>	Lifting spindle, protected against twisting by square tube
		<b>R</b>	Rotating spindle
<b>3</b>	Transmission	<b>2:1</b>	Gearboxes available for all sizes
		<b>3:1</b>	
<b>4</b>	Type of spindle	<b>T</b>	Trapezoidal screw drive
		<b>K</b>	Ball screw drive
<b>5</b>	Spindle dimension		e.g. 2005 = diameter 20 mm, pitch 5 mm
<b>6</b>	Stroke in [mm]		Specification of the stroke length
<b>7</b>	Spindle extension VL for version N/V in [mm]		Spindle extension VL, Usable thread length NL eg due to block dimension bellows, mounting situation see product drawings S. 67-68.
	Usable stroke length for version R in [mm]		
<b>8</b>	Spindle end	<b>M</b>	Metric threaded stem
		<b>A</b>	End with chamfer
		<b>S</b>	Custom (according to specification, description or drawing)
		<b>Z</b>	Centric stem (standard for version R)
<b>9</b>	Attached part for version N/VK/VP	<b>O</b>	None
		<b>BP</b>	With fastening plate mounted
		<b>GA</b>	With spherical bearing mounted
		<b>GK</b>	With fork end mounted
		<b>HG</b>	With high-performance fork end mounted
	Nut type for version R	<b>F-D</b>	Flanged nut according to DIN 69051 (flange direction to housing)
		<b>F-N</b>	Flanged nut according to NEFF-Norm (flange direction to housing)
		<b>D-F</b>	Flanged nut according to DIN 69051 (flange direction to screw end)
<b>N-F</b>	Flanged nut according to NEFF-Norm (flange direction to screw end)		
<b>10</b>	Spindle cover	<b>O</b>	None
		<b>FB</b>	With bellows
		<b>SF</b>	With spiral spring cover
<b>11</b>	Anti-unscrewing device	<b>O</b>	None
		<b>AS</b>	With (installed as standard in KGT)
<b>12</b>	Installation position/attachment side	<b>A</b>	See dimensions G1-G3
		<b>B</b>	
		<b>C</b>	
		<b>D</b>	
		<b>E</b>	
		<b>F</b>	
<b>13</b>	Shaft arrangement	<b>1WD</b>	1 shaft end side D
		<b>1WE</b>	1 shaft end side E
		<b>1WF</b>	1 shaft end side F
		<b>2WDE</b>	2 shaft ends sides D and E
		<b>2WDF</b>	2 shaft ends sides D and F
		<b>2WFE</b>	2 shaft ends sides F and E
		<b>3W</b>	3 shaft ends
<b>14</b>	Gear wheel arrangement	<b>RO</b>	Gear wheel above (viewed on attachment side)
		<b>RU</b>	Gear wheel below (viewed on attachment side)
<b>15</b>	requirements	<b>O</b>	None
		<b>1</b>	According to specification, description or drawing

# Worm gear screw jacks

Examples for arrangements and direction of rotation

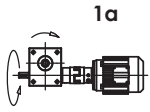

1a

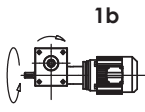

1b

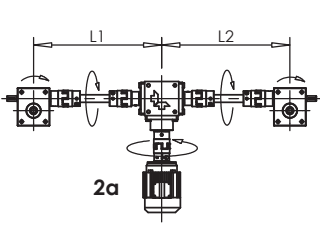

2a

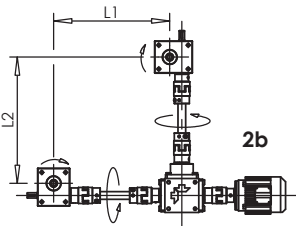

2b

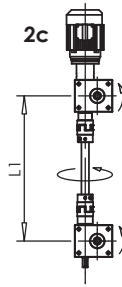

2c

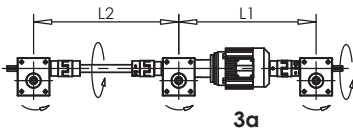

3a

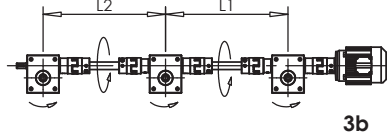

3b

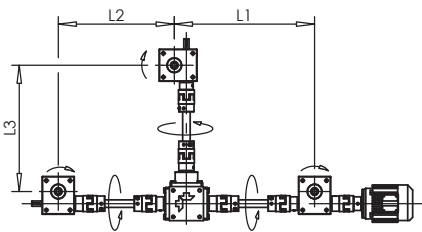

3c

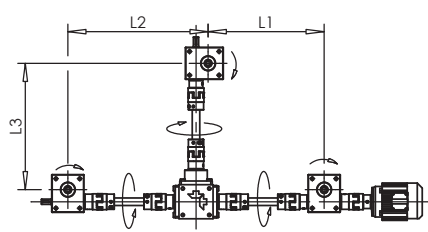

3d

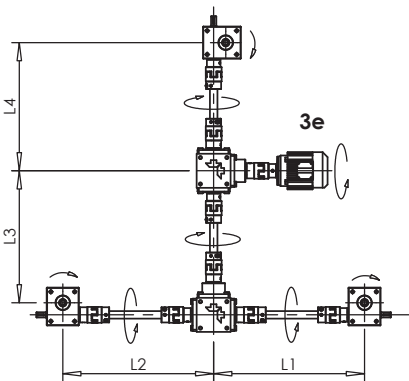

3e

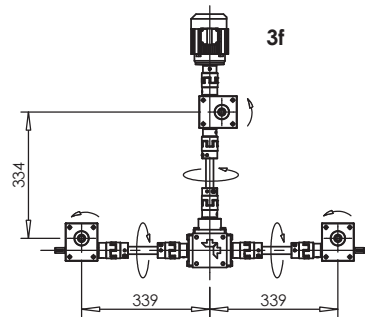

3f

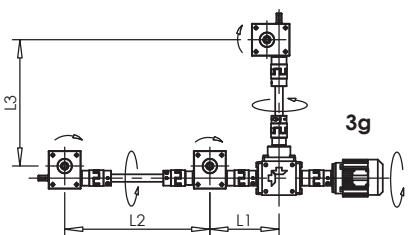

3g

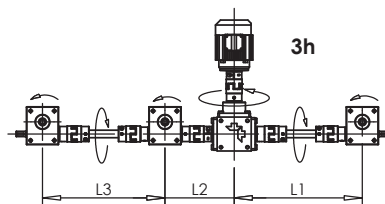

3h

# Worm gear screw jacks

Examples for arrangements and direction of rotation

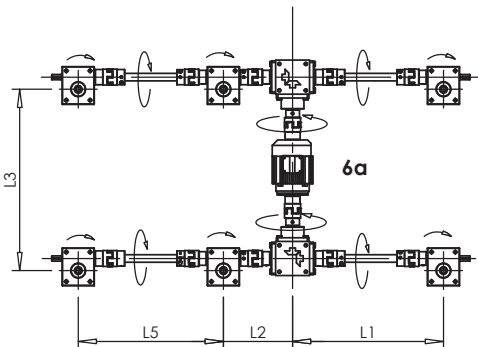
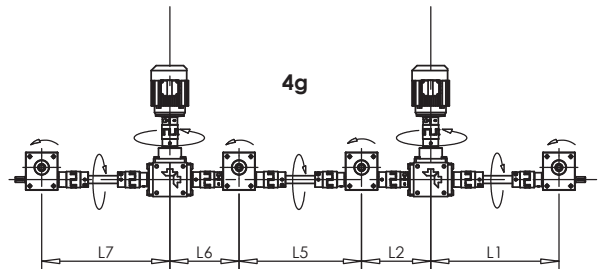
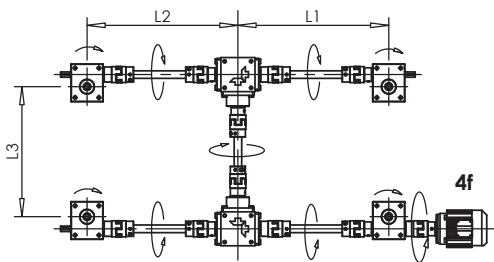
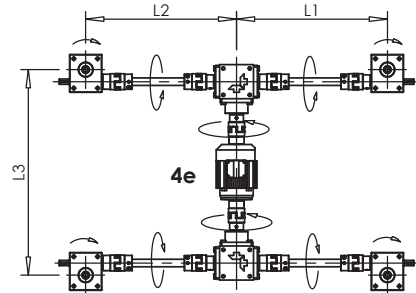
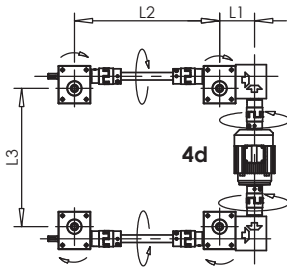
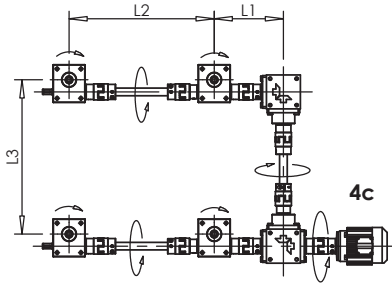
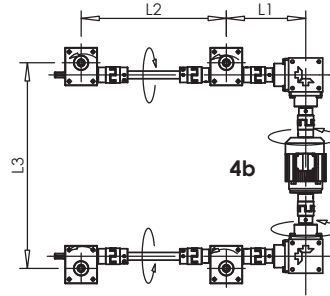
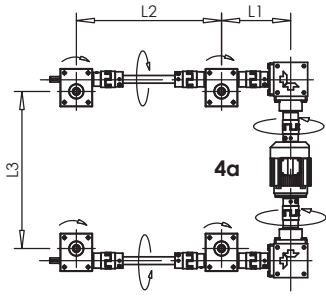

# Calculation

## Screw Jacks

### The general procedure for the design of worm gear screw jacks is as follows:

1. Definition of the speed, the required force and the possible installation position of the worm gear screw jack.
2. Selection of the drive elements (couplings, shafts, bevel gearbox, motors) for the synchronous drive of the individual worm gear screw jacks. The following criteria are decisive here:
  - Lowest possible load on the individual transmission elements. In particular, the introduction of the total drive torque via the toothing of a bevel gearbox is to be avoided
  - Lowest possible number of transmission elements and short connecting shafts.
  - Device for the protection of the unit by torque-limiting coupling.

Selection of a worm gear screw jack and the associated drive



## Calculation

### Screw Jacks

#### Forces and torques on the worm gear screw jack

Note: Forces and torques can only be estimated using simplifying assumptions; friction coefficients of sliding pairings and thus their temperature rise and service life are functions of load, speed, temperature and lubrication conditions; critical speeds and buckling lengths depend on the rigidity and mass of the clamping and the machine frame etc.

$F_{\text{eff}}$	=	Axial force on the lifting spindle
$F_S$	=	Resultant of all lateral forces acting on the lifting spindle
$M$	=	Torque of the lifting spindle or nut (omitted in version V)
$V_H$	=	Stroke speed
$F_{\text{ax}}$	=	Axial force on the drive shaft
$F_r$	=	Radial force on the drive shaft
$M_T$	=	Drive torque
$n_T$	=	Drive speed
$P$	=	Pitch of the spindle
$i$	=	Transmission ratio
$\eta$	=	Efficiency
$M_0$	=	Idling torque (p. 28 (Nm))

$$F_{\text{eff}} = \frac{M_T - M_0}{\frac{P}{i}} \cdot 2 \cdot \pi \cdot \eta$$

#### Drive power

$$P_a = \frac{M_d \cdot n}{9550}$$

$M_d$	Required drive torque [Nm]
$n$	Spindle speed [rpm]
$P_a$	Required drive power [KW]

# Calculation

## Screw Jacks

### Theoretically critical buckling force, worm gear screw jack M/J, high-speed screw jack G1-G3 with ball screw

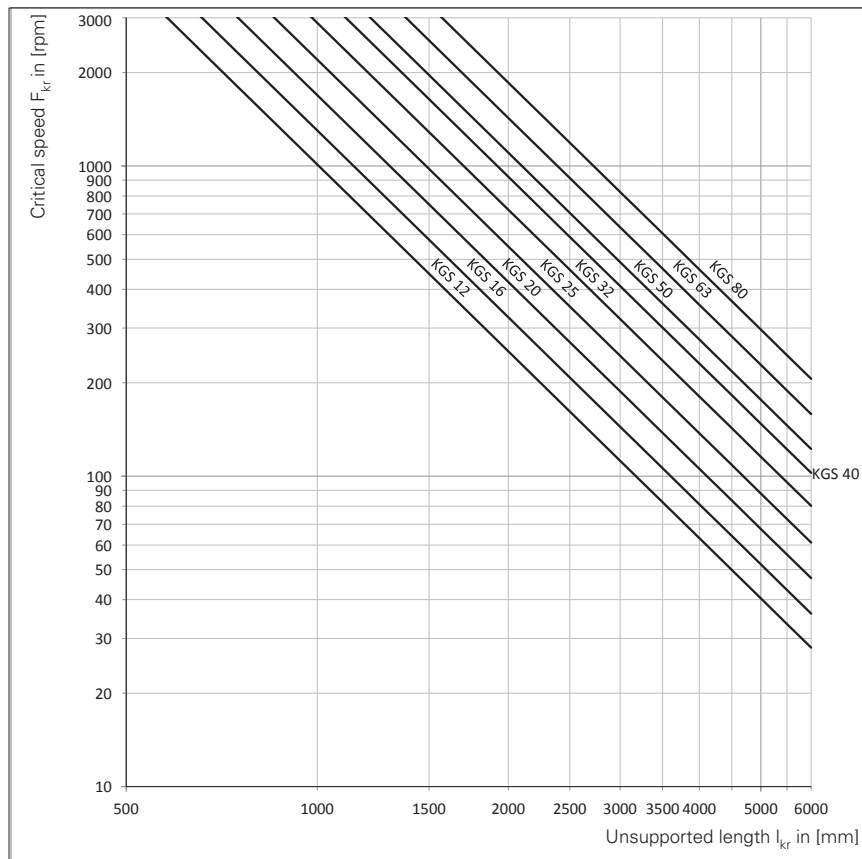
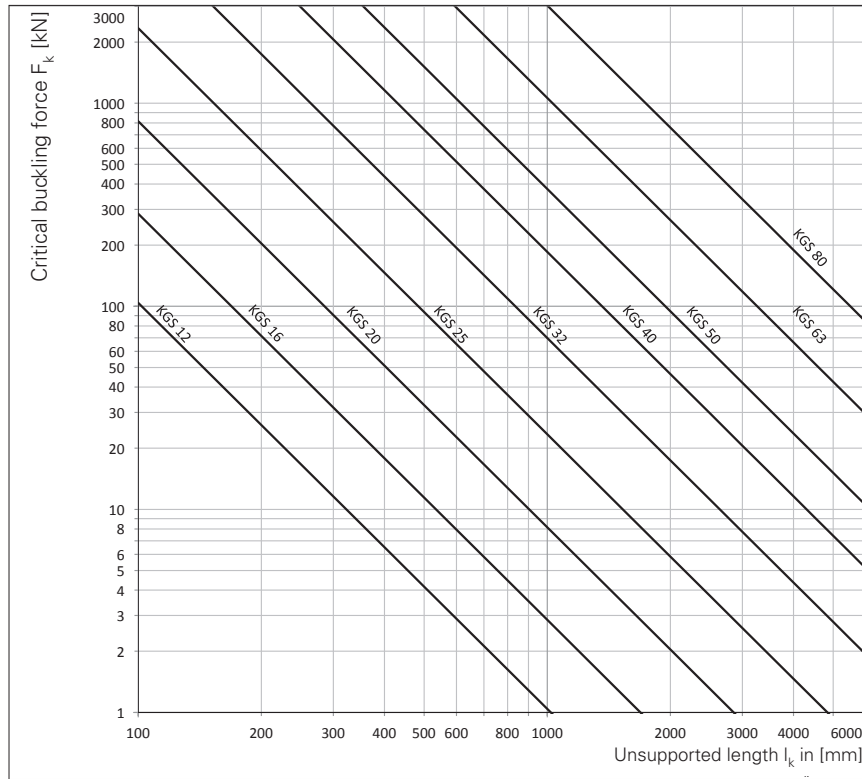

# Calculation

## Screw Jacks

Theoretically critical buckling force, worm gear screw jack M/J, high-speed screw jack G1-G3 with trapezoidal-threaded spindle

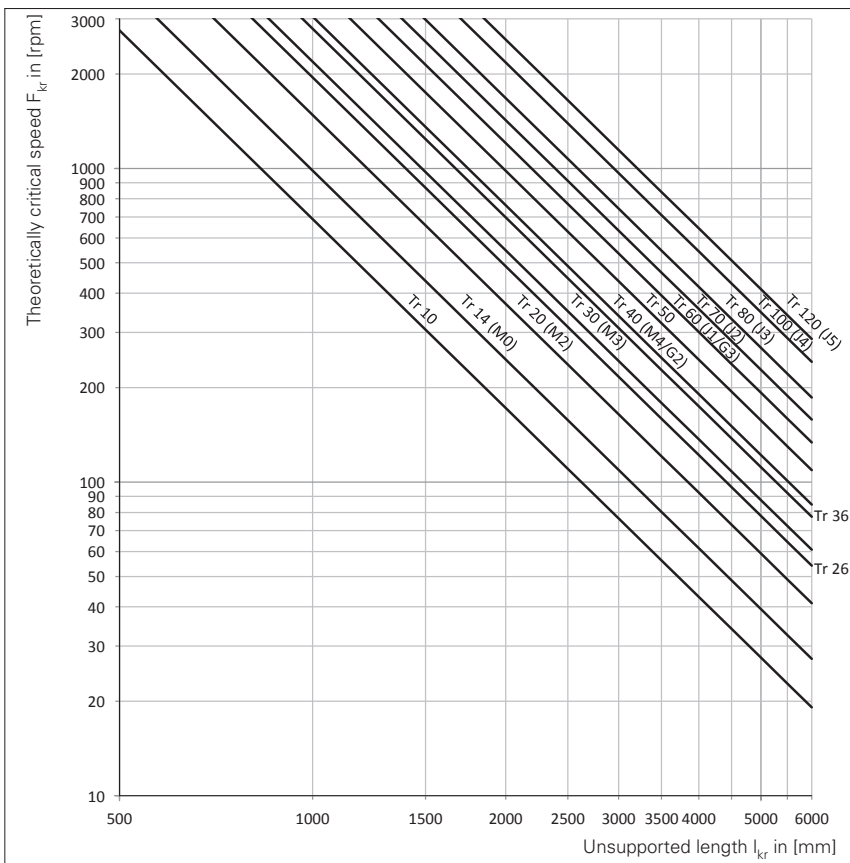
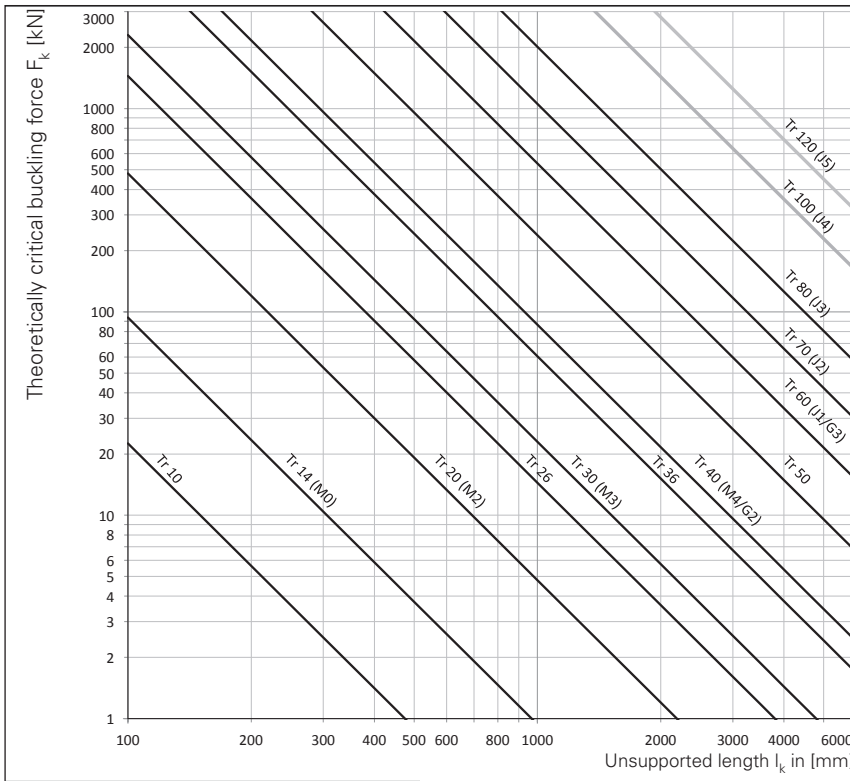

# Calculation

## Screw Jacks

### Critical buckling force

With slim lifting spindles there is a risk of lateral buckling under compressive loads.

The safety factors applying to the system must be considered before determining the permissible compressive force on the spindle.

### Types of bearing

Typical values for the correction factor  $f_k$  according to the classic installation cases for standard spindle bearings.

### Neff bearing case I

Fixed bearing-loose end, correction factor  $f_k=0.25 / f_{kr}=0.43$

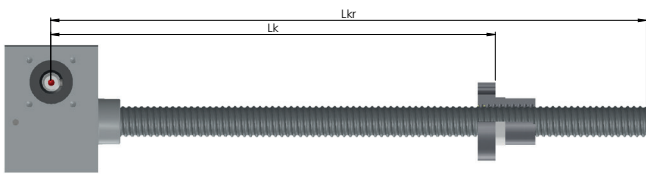

### Neff bearing case II

Movable bearing-movable bearing, correction factor  $f_k=1 / f_{kr}=1.21$

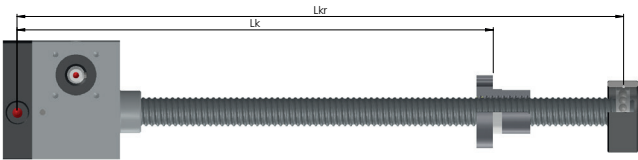

### Neff bearing case III

Fixed bearing-movable bearing, correction factor  $f_k=2.05 / f_{kr}=1.89$

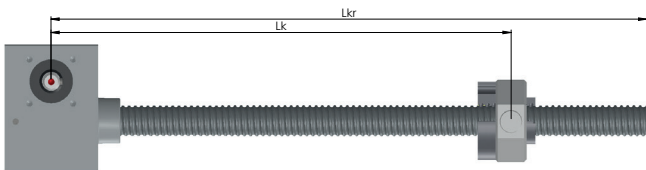

### Neff bearing case IV

Fixed bearing-fixed bearing, correction factor  $f_k=4 / f_{kr}=2.74$

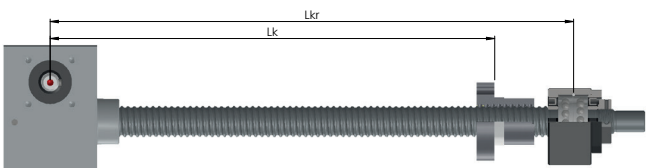

### Critical buckling force, worm gear screw jack M/J, high-speed screw jack G1-G3 with ball screw/trapezoidal-threaded spindle

#### Theoretical critical buckling force in [kN]:

$$F_k = \left( \frac{d_2}{L_k} \right)^2 \cdot 10^5 : 1000$$

#### Maximum permissible axial force in:

$$F_{zul} = F_k \cdot f_k \cdot \frac{1}{S_f}$$

$F_{zul}$	Maximum permissible axial force [kN]
$F_k$	Theoretical critical buckling force [kN]
$f_k$	Correction factor that takes into account the type of spindle bearing
$d_2$	Core diameter of the spindle [mm]
$L_k$	Unsupported length on which the force acts on the spindle [mm]
$S_f$	Safety factor (specified by the user)

#### Caution!

The operating force must not exceed 80% of the maximum permissible axial force!

### Critical buckling force, worm gear screw jack M/J, high-speed screw jack G1-G3 with ball screw

#### Theoretically critical speed in [1/min]

$$F_{kr} = \left( \frac{d_2}{L_{kr}} \right)^2 \cdot 10^8$$

$n_{zul}$	Maximum permissible spindle speed [rpm]
$n_{kr}$	Theoretically critical spindle speed [rpm] that leads to resonant vibrations
$f_{kr}$	Correction factor that takes into account the type of spindle bearing
$d_2$	Core diameter of the spindle [mm]
$L_{kr}$	unsupported spindle length [mm]

#### Caution!

The operating force must not exceed 80% of the maximum permissible axial force!

#### Maximum permissible speed in [rpm]

$$f_{kr} = F_{kr} \cdot f_k \cdot 0.8$$



# Drive sizing

## Required drive torque

### Required drive torque of a worm gear screw jack

The required drive torque of a worm gear screw jack is governed by the axial load acting on the jack screw, the transmission ratio and the efficiency. It should be noted that the breakaway torque may be considerably higher than the torque required for continuous running. This applies in particular to worm gear screw jacks with low efficiency after a long standstill period. The acceleration torque should be checked if necessary in cases with large spindle pitches and very short start-up times.

$$M_T = \frac{F_{\text{eff}}}{2 \cdot \pi \cdot \eta} \cdot \frac{p}{i} + M_0$$

#### Note:

The required drive torque does not represent a criterion for the selection of the motor. The user must decide here, what power he considers necessary!

- $M_T$  is the required drive torque of the worm gear screw drive at the worm shaft [Nm].
- $F_{\text{eff}}$  is the actual force acting on the jack screw [kN].
- $\eta$  is the efficiency of the worm gear screw jack in decimal notation on e.g. 0.32 instead of 32 %.  $\eta$  is an average value determined by measurement.
- $\frac{p}{i}$  is the transmission ratio of the worm gear screw drive in mm stroke length per revolution of the worm shaft.
- $M_0$  is the idle torque of the worm gear screw drive [Nm].  $M_0$  is determined by measurements undertaken after a brief running in period with liquid grease lubrication at room temperature. It represents an average value which may vary to a greater or lesser extent, depending on the running-in state, lubricant and temperature. For values, see table.

### Required drive torque for a worm gear screw jack system

The required drive torque for a worm gear screw jack system is governed by the drive torque values for the individual jacks with allowance for the static and dynamic frictional losses in transmission components (coupling, universal joint shafts, pillow blocks, angle gear boxes, etc.). It is useful to draw a diagram illustrating the flow of forces.

$$M_{\text{drive motor}} = M_{T \text{ SHG1}} \cdot \frac{1}{\eta_{V1}} + M_{T \text{ SHG2}} + M_{T \text{ SHG3}} \cdot \frac{1}{\eta_{V2}} \cdot \frac{1}{\eta_K}$$

- $M_{T \text{ SHG1}}$  is the required drive torque for the worm gear screw jack SHG 1. It should be noted that the start-up torque (breakaway torque and possibly acceleration torque) may be considerably higher than the torque required for continuous running. This applies in particular to worm gear screw jacks with low efficiency after a long standstill period.
- $\eta_{V1}$  (V1) includes the static and dynamic frictional losses in the pedestal bearings and couplings.
- $\eta_{V2}$  is the efficiency of connecting shaft V2.
- $\eta_V$  = 0.75...0.95 depending on the length of the shaft and number of pedestal bearings.
- $\eta_K$  is the efficiency of the bevel gearbox (only for the force flow via the toothing, i.e. between connecting shaft V2 and the drive motor).
- $\eta_K = 0.90$

### Maximum drive power in KW:

	M 0	M 1	M 2	M 3	M 4	M 5	J 1	J 2	J 3	J 4	J 5
Trans. H (trapezoidal)	0.18	0.3	0.55	1.18	2.3	4.7	6.5	8.4	10.9	14.7	19
Trans. L (trapezoidal)	0.12	0.19	0.35	0.75	1.4	3	4.2	5.4	7.3	9.3	12
Ball screw	0.18	0.3	0.56	0.95	1.7/3.2	5.9	–	–	13.9	–	–

These values do not represent a criterion for the choice of drive motor. This must be selected instead according to torque, speed and operating conditions.

# Drive sizing

## Required drive torque

### Maximum drive torque

If the worm gear screw jack jams as a result of the spindle coming into contact with an obstacle, the tothing can still absorb the following maximum torque values  $M_T$  at the drive shaft.

In the case of screw jacks connected in series, the screw jack closest to the drive can absorb this torque at its drive shaft.

Size	$M_{Tmax}$ [Nm]
M 0	1.5
M 1	3.4
M 2	7.1
M 3	18
M 4	38
M 5	93
J 1	148
J 2	178
J 3	240
J 4	340
J 5	570

### Acceleration values

Three-phase asynchronous motor, 4-pole:

- Approx. 0.5 m/s<sup>2</sup> (when switched on directly).

Servo motor:

- Max. 5 m/s<sup>2</sup> (limited by max. drive torque).  
When using screw jacks in conjunction with servo motors, note that:
- Greater masses are moved compared with linear axes.
- Predominantly constant speeds with different speeds of rotation are used.
- Use is often in the area of the adjustment/positioning of equipment.
- Positions are travelled to with relatively short duty cycles and high acceleration values are therefore less frequently called for.
- High acceleration values have only a negligible effect on the overall stroke time, because of the low stroke speeds.

### Forces and torque values acting on the drive shaft

If worm gear screw jacks are not driven free of lateral forces by means of a coupling connected to the motor shaft, but are instead driven by chains or belts, care must be taken to ensure that the radial force acting on the drive shaft does not exceed the limit values (see below).

In the worst case due to deflection caused by the radial force  $F_R$  the worm shaft will lift off of the worm gear wheel. This must be avoided, since it impairs the engagement between worm shaft and worm gear wheel and leads to higher wear.

Size	$F_{Rmax}$ [kN]
M 0	0.07
M 1	0.1
M 2	0.2
M 3	0.3
M 4	0.5
M 5	0.8
J 1	0.8
J 2	1.3
J 3	1.3
J 4	2.1
J 5	3.1

### Selection of drive motor

A suitable drive motor can be selected if the required drive torque and drive speed are known. After selecting a drive motor, check that it will not overload any of the worm gear screw jacks or transmission components. This risk may occur, in particular, in installations with several screw jacks if they are loaded unevenly. It will generally be necessary to install limit switches or torque-limiting couplings to protect the installation against impacting against end positions and obstacles.

### Forces and torque values on the motor shaft

Toothed-belt or chain drives may exert considerable radial forces on the motor shaft if a very small sprocket is used. Please consult the motor manufacturer in cases of doubt.

### Selection of a bevel gearbox

Selection of a bevel gearbox is governed by the following factors:

- Drive torque
- Drive speed (see dimensional tables)
- Duty cycle and drive power
- Forces and torques acting on the ends of the shaft (please consult us in cases of doubt).

### Required drive speed

The required drive speed is governed by the desired stroke speed, the transmission ratio of the screw jack and the transmission ratio of the other transmission components. A particular stroke speed can normally be achieved in several ways. Correct selection depends on the following criteria:

- Favourable efficiency.
- Minimum load on transmission components in order to achieve compact, low-cost design.
- Avoiding critical speeds for screw jacks and connecting shafts.

### Screw jack nut torques

The nut torque (M) of the screw jack is the torque that the screw jack exerts on the mounting plate (all N versions except V), or the torque that the screw applies to the travelling nut (R Version). It is not to be confused with the drive torque ( $M_T$ ) of the screw jack gears on the worm shaft.

$$M \text{ [Nm]} = F_{\text{eff}} \text{ [kN]} \cdot f_M \text{ (applicable in the areas of moderate and high loads)}$$

M is the screw jack nut torque [Nm] for the "Lift under Load" movement.

$F_{\text{eff}}$  is the actual supported axial force [kN].

$f_M$  is a conversion factor that accounts for spindle geometry and friction. The value is applicable under normal lubrication conditions. The higher value applies to dry friction and static friction. In the case of ball screw drives,  $f_M$  is practically constant.

Size	$f_M$ (Trapezoidal screw)	$f_M$ (Ball screw)
M 0	1.4	1.2
M 1	1.6	1.6
M 2	1.8	1.6
M 3	2.7	1.6
M 4	3.4	1.6/3.2
M 5	4.6	3.2
J 1	5.5	–
J 2	6.4	–
J 3	7.2	3.2
J 4	8.0	–
J 5	10.6	–

# Accessories Worm gear screw- jacks

## Mounting feet BL-L

Supplied loose with mounting bolts for jack. Burnished.  
M 1 + 2 with version N-KGT not on side F. Standard: side E.

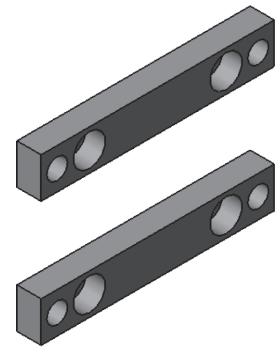
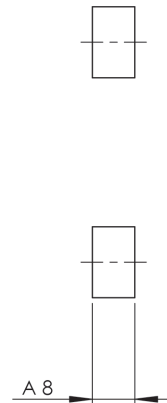
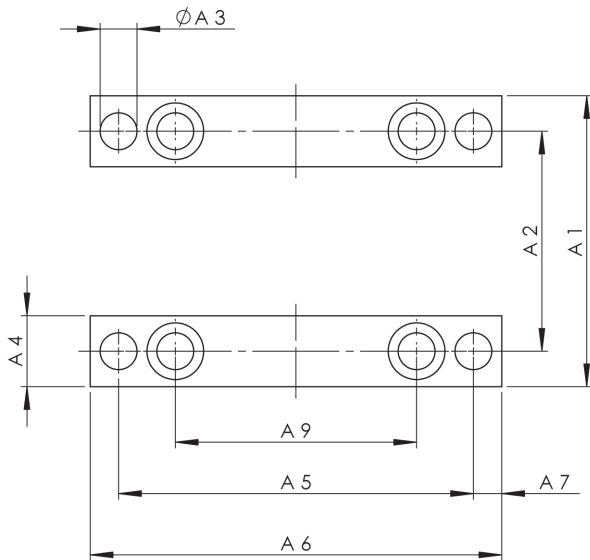

Size	Dimensions [mm]									Weight [kg]
	$A_1$	$A_2$	$A_3$	$A_4$	$A_5$	$A_6$	$A_7$	$A_8$	$A_9$	
BL - L M 0	50	38	6.5	12	75	90	7.5	10	48	0.1
BL - L M 1	72	52	8.5	20	100	120	10	10	60	0.3
BL - L M 2	83	63	8.5	20	120	140	10	10	78	0.4
BL - L M 3	105	81	11	24	150	170	10	12	106	0.8
BL - L M 4	145	115	13.5	30	204	230	13	16	150	1.7
BL - L M 5	171	131	22	40	236	270	17	25	166	3.9
BL - L J 1	205	155	26	50	250	290	20	30	170	5.8
BL - L J 2	235	170	32	65	290	340	25	40	190	10
BL - L J 3	235	170	32	65	290	340	25	40	190	10
BL - L J 4	270	190	39	80	350	410	30	50	230	20.8
BL - L J 5	330	230	45	100	430	500	35	60	290	34.4

# Universal joint adapter

## Universal joint adapter KA-ZL-CD

Supplied loose with mounting bolts for jack.

Burnished.

Standard: side E. Side F please specify.

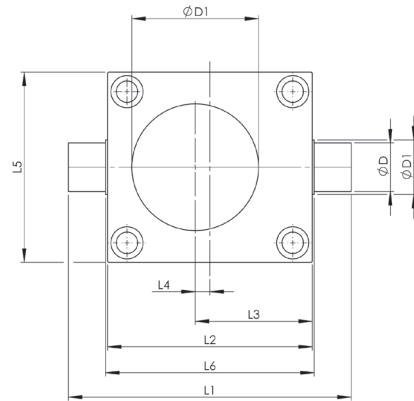
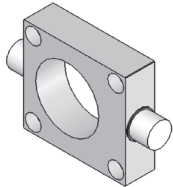

Lengthwise	$L_1$	$L_2$	$L_3$	$L_4$	$L_5$	$L_6$	$\varnothing D_{f8}$	$\varnothing D_1$	$\varnothing D_2$	B
M 0	80	60	38	8	50	64	10	30	13	15
M 1	110	80	49	9	72	84	15	35	18	20
M 2	140	100	60	10	85	104	20	45	23	25
M 3	170	130	76	11	105	134	25	55	28	30
M 4	240	180	102	12	145	184	35	70	38	40
M 5	270	200	117	17	165	204	45	95	48	50
J 1	290	210	120	15	195	214	50	100	56	60
J 2	330	240	140	20	220	244	70	115	76	80
J 3	330	240	140	20	220	244	70	130	76	80
J 4	410	290	165	20	250	294	80	155	88	90
J 5	520	360	210	30	300	364	90	185	96	100

## Universal joint adapter KA-ZQ-AB

Supplied loose with mounting bolts for jack.

Burnished.

Standard: side E. Side F please specify.

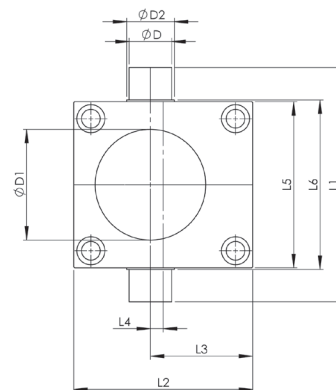
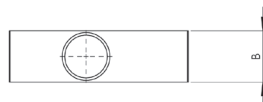
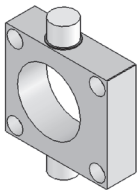

Quer	$L_1$	$L_2$	$L_3$	$L_4$	$L_5$	$L_6$	$\varnothing D_{f8}$	$\varnothing D_1$	$\varnothing D_2$	B
M 0	70	60	38	8	50	54	10	30	13	15
M 1	102	80	49	9	72	76	15	35	18	20
M 2	125	100	60	10	85	89	20	45	23	25
M 3	145	130	76	11	105	109	25	55	28	30
M 4	205	180	102	12	145	149	35	70	38	40
M 5	235	200	117	17	165	169	45	95	48	50
J 1	289	210	120	15	195	199	50	100	56	60
J 2	313	240	140	20	220	224	70	115	76	80
J 3	313	240	140	20	220	224	70	130	76	80
J 4	370	290	165	20	250	254	80	155	88	90
J 5	460	360	210	30	300	304	90	185	96	100

# Universal joint bearing

## Universal joint bearing flange

for mounting a universal joint adaptor or a universal joint bearing

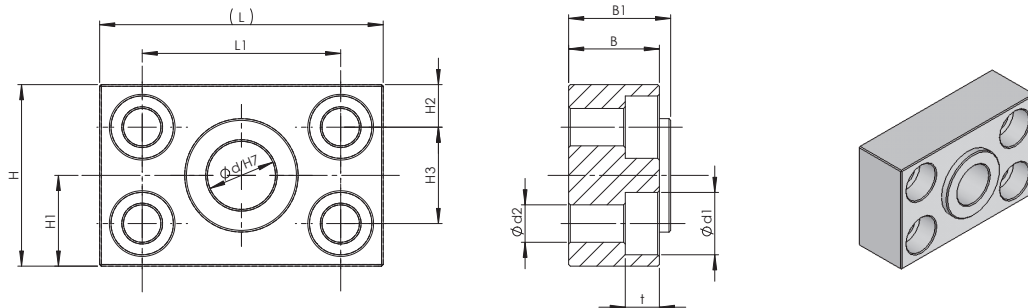

Size	$\phi d^{H7}$	$\phi d_1$	$\phi d_2$	t	B	$B_1$	H	$H_1$	$H_2$	$H_3$	L	$L_1$
KLF-0	10	11	6.6	6.8	16	18	32	16	7.5	17	50	35
KLF-1	15	15	9	9	20	22	36	18	9	18	65	45
KLF-2	20	15	9	9	20	23	40	20	10	20	70	50
KLF-3	25	18	11	11	20	22.5	54	27	12	30	80	58
KLF-4	35	20	13.5	13	30	35	70	35	15	40	100	70
KLF-5	45	33	22	21.5	40	43	80	40	20	40	140	100
KLF-200	70	48	33	32	50	58	125	62.5	30	65	220	160
KLF-300	80	57	39	38	62	70	144	72	34	76	245	180
KLF-400	80	57	39	38	62	70	144	72	34	76	245	180
KLF-500	90	66	45	44	80	90	160	80	40	80	28	200

## Universal joint bearing pedestal

for mounting a universal joint adaptor or a universal joint bearing.

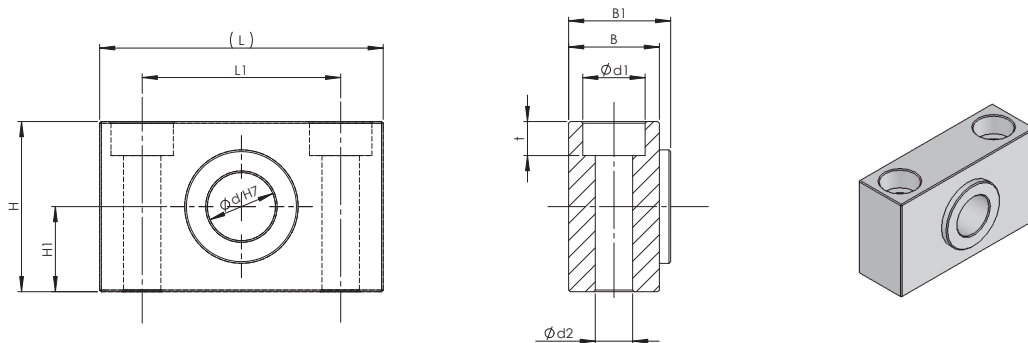

Size	$\phi d^{H7}$	$\phi d_1$	$\phi d_2$	t	B	$B_1$	H	$H_1$	L	$L_1$
KLB-0	10	11	6.6	6.8	16	18	30	15	50	35
KLB-1	15	15	9	9	20	22	34	17	65	45
KLB-2	20	15	9	9	20	23	38	19	70	50
KLB-3	25	18	11	11	20	22.5	54	27	80	58
KLB-4	35	20	13.5	13	30	35	70	35	100	70
KLB-5	45	33	22	21.5	40	43	80	40	140	100
KLB-200	70	48	33	32	63	71	124	62	220	160
KLB-300	70	57	39	38	63	71	144	72	245	180
KLB-400	80	57	39	38	63	71	144	72	245	180
KLB-500	90	66	45	44	80	90	160	80	280	200

# Attachments

## Top plate BP

Screwed onto the mounting thread of the screw jack and protected against rotation.

Standard: Bore pattern BP symmetrically to SHG housing.

Note: Please specify alignment in case of version V.

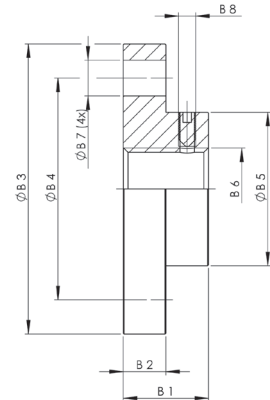
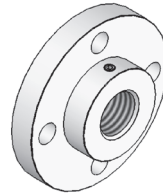

Size	Dimensions [mm]								Weight [kg]
	B <sub>1</sub>	B <sub>2</sub>	∅ B <sub>3</sub>	B <sub>4</sub>	B <sub>5</sub>	B <sub>6</sub>	B <sub>7x4</sub>	B <sub>8</sub>	
BP M 0	16	6	50	40	26	M8	7	M4	0.1
BP M 1	20	7	65	48	30	M12	9	M5	0.2
BP M 2	21	8	80	60	38.7	M14	11	M6	0.3
BP M 3	23	10	90	67	46	M20	11	M8	0.6
BP M 4	30	15	110	85	60	M30	13	M8	1.2
BP M 5	50	20	150	117	85	M36	17	M10	4.8
BP J 1	50	25	170	130	90	M48 x 2	21	M10	5
BP J 2	60	30	200	155	105	M56 x 2	25	M12	7.7
BP J 3	60	30	220	170	120	M64 x 3	25	M12	9.8
BP J 4	80	40	260	205	145	M72 x 3	32	M12	18.4
BP J 5	120	40	310	240	170	M100 x 3	38	M12	29.6

## Fork end GK

Screwed onto the mounting thread of the screw jack and protected against rotation. Supplied with split pins and collar pins.

Standard: Collar pin mounted parallel to the drive shaft.

Note: Please specify alignment in case of version V.

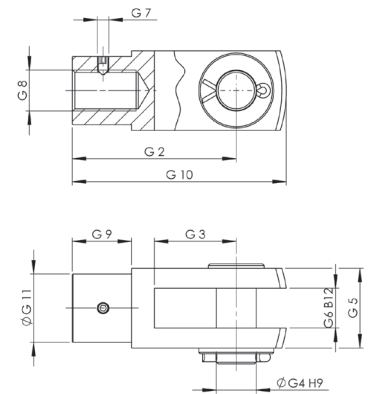
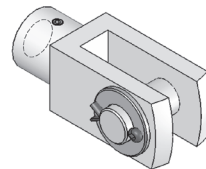

Size	Dimensions [mm]										Weight [kg]
	G <sub>2</sub>	G <sub>3</sub>	G <sub>4 H9</sub>	G <sub>5 k</sub>	G <sub>6 B12</sub>	G <sub>7</sub>	G <sub>8</sub>	G <sub>9</sub>	G <sub>10</sub>	G <sub>11</sub>	
GK M 0	32	16	8	16	8	M4	M8	12	42	14	0.04
GK M 1	48	24	12	24	12	M5	M12	18	62	20	0.15
GK M 2	56	28	14	28	14	M6	M14	22	72	24.5	0.2
GK M 3	80	40	20	40	20	M8	M20	30	105	34	0.8
GK M 4	120	60	30	60	30	M8	M30	43	160	52	2.5
GK M 5	144	72	35	70	35	M10	M36	54	188	60	3.8

# Attachments

## Spherical bearing GA

Screwed onto the mounting thread of the screw jack and protected against rotation.

Standard: Position of the transverse bore parallel to drive shaft.

Note: Please specify alignment in case of version V.

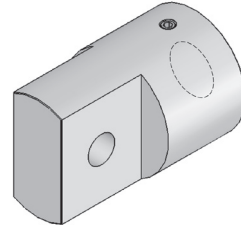
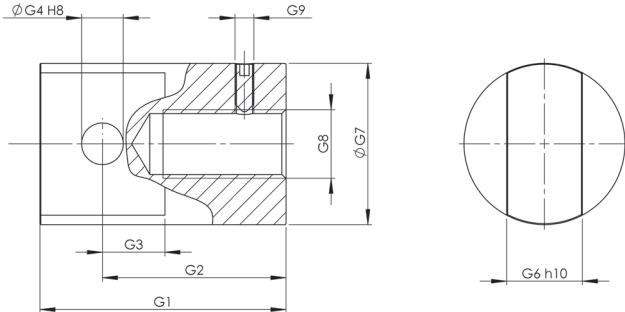

Size	Dimensions [mm]								Weight [kg]
	G <sub>1</sub>	G <sub>2</sub>	G <sub>3</sub>	G <sub>4</sub> H8	G <sub>6</sub> H10	G <sub>7</sub>	G <sub>8</sub>	G <sub>9</sub>	
GA M 0	40	30	10	8	12	25	M8	M4	0.1
GA M 1	55	40	15	10	15	30	M12	M5	0.2
GA M 2	63	45	18	12	20	39	M14	M6	0.3
GA M 3	78	53	20	16	30	45	M20	M8	0.6
GA M 4	100	70	30	20	35	60	M30	M8	1.2
GA M 5	130	97	33	22	40	85	M36	M10	2.5
GA J 1	120	75	45	40	60	90	M48 x 2	M10	4.8
GA J 2	130	90	50	50	70	105	M56 x 2	M12	4.8
GA J 3	155	105	60	60	80	120	M64 x 3	M12	8.0
GA J 4	220	135	85	80	110	145	M72 x 3	M12	22.5
GA J 5	300	200	100	90	120	170	M100 x 3	M12	31.5

## High-performance joint head HG

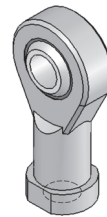
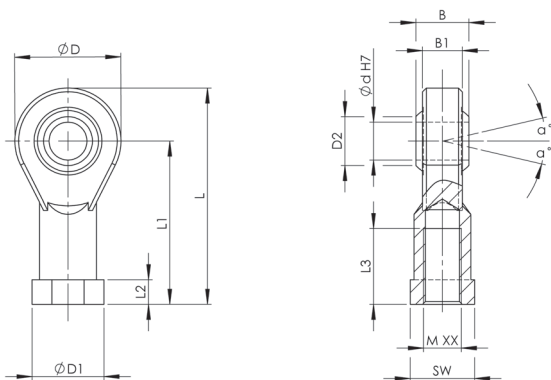

Dimension	Ød <sup>H7</sup>	M	B	B1	D	D1	D2	L	L1	L2	L3	SW	Co / (KN)	Angle (°)	Weight
HG-0	10	M 10	14	10.5	28	19	12.9	57	43	6.5	20	17	17.65	13	0.076
HG-1	12	M 12	16	12	32	22	15.4	66	50	6.5	22	19	20.6	13	0.115
HG-2	14	M 14	19	13.5	36	25	16.8	75	57	8	25	22	29.4	15	0.17
HG-3	20	M 20x1.5	25	18	50	34	24.3	102	77	10	33	32	49.1	15	0.415
HG-4	30	M 30x2	37	25	70	50	34.8	145	110	15	51	41	99.1	15	1.13
HG-5	35	M 36x2	43	28	80	58	37.7	165	125	17	65	50	125	15	1.6
HG-6	70	M 56x4	49	42	160	98	92	280	200	20	80	85	630	6	8.4

# Bellows FB

Bellows cover for the protection of the spindle against external influences. Available in diameters from 20 mm to 120 mm in 1 mm steps. Horizontal and vertical installation possible.

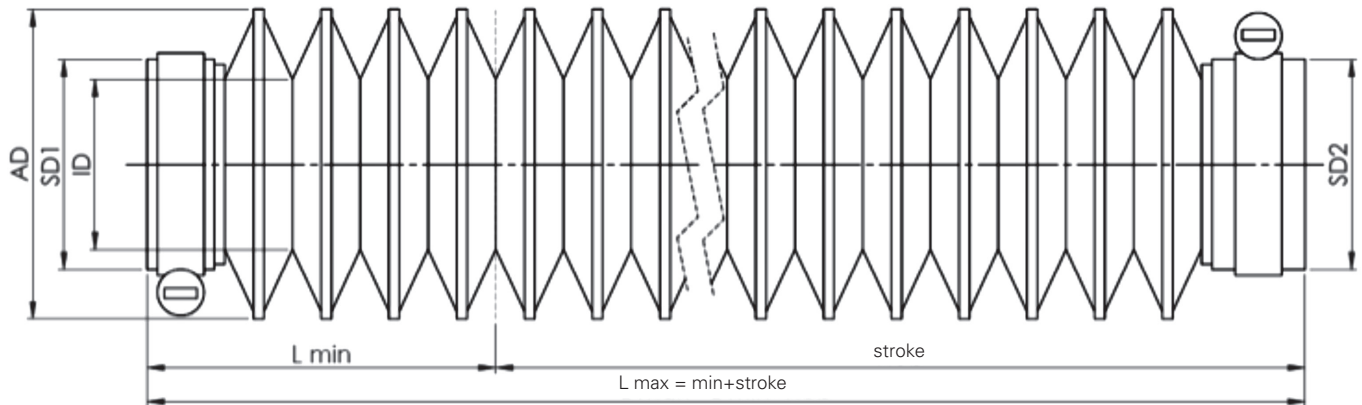

## Calculation of bellows FB

For the dimensioning of the spindle length of screw jacks or screw drives with bellows protection, the spindle must be extended by Lmin.

### TO version (thermoplastic sprayed)

$$L_{min} = F_z \cdot L_{minF}$$

$$F_z = \frac{L_{max}}{F_t} : 1,8$$

$$F_t = \frac{AD - ID}{2}$$

$$L_{minF} = 6 \text{ mm}$$

If space is limited, LminF can be shortened after consultation to the factor 0.835.

### SB version (disk bellows)

$$L_{min} = F_z \cdot L_{minF}$$

$$F_z = \frac{L_{max}}{F_t} \cdot 1,1$$

$$F_z = \frac{L_{max}}{F_t} : 1,1$$

$$F_t = \frac{AD - ID}{2}$$

$$L_{minF} = 2,5 \text{ mm}$$

Lmin	compressed length [mm]
Lmax	extended length [mm]
Ft	fold depth [mm]
Fz	no. of folds
LminF	compressed length per fold [mm]

If space is limited, LminF can be shortened after consultation to the factor 0.64.

A support ring must be installed every 400 mm in case of horizontal installation or every 1000 mm in case of vertical installation. The dimension Lmin is extended here by 1.1 mm per support ring.



# Bellows FB

## Ordering code for bellows FB

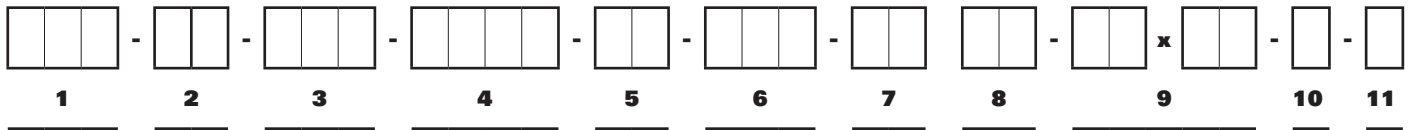

No.	Designation	Code	Description
<b>1</b>	Product abbreviation	<b>KGT</b>	Ball screw
<b>2</b>	Design	<b>TO</b>	Thermoplastic (sprayed)
		<b>SB</b>	Disk bellows
		<b>GR</b>	Round fabric, coated
		<b>GV</b>	Polygonal fabric, coated
<b>3</b>	Lmin in [mm]		Retraction length / compressed length of bellows
<b>4</b>	Stroke/Lmax in [mm]		Stroke/maximum extension length
<b>5</b>	Inside diameter ID in [mm]		> same as diameter of spindle
<b>6</b>	Outside diameter OD in [mm]		
<b>7</b>	Cuff diameter SD1 in [mm]		Inside diameter of the bellows end 1
<b>8</b>	Cuff diameter SD2 in [mm]		Inside diameter of the bellows end 2
<b>9</b>	Spindle dimension		e.g. 20x4 (diameter 20 mm, pitch 4 mm)
<b>10</b>	Installation position	<b>H</b>	Horizontal
		<b>V</b>	Vertical
<b>11</b>	Special requirements for nut	<b>0</b>	none
		<b>1</b>	According to specification, description or drawing

# Spiral spring cover SF

Spiral springs are used as reliable spindle protective covers against external influences.

The material used is hardened spring band steel. If the spiral springs are exposed to cooling lubricants with a high water content, it is recommended to use stainless spiral springs. For dimensions see Accessories pages 49 to 51

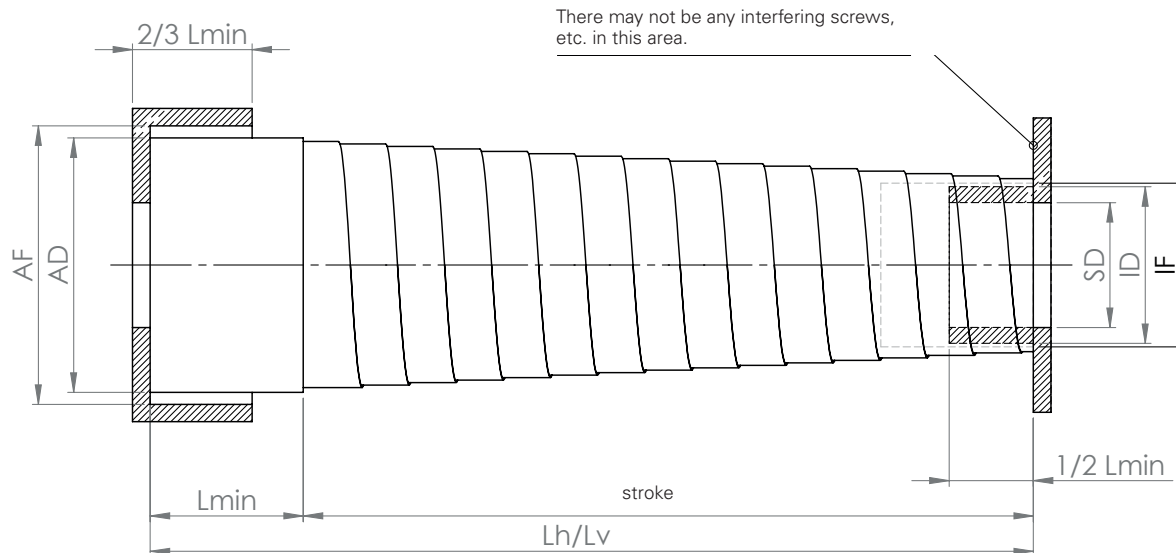

SD = Maximum outside diameter / spindle diameter

ID = Inside diameter of the spiral spring ±1 mm

AD = Diameter of the spiral spring

L<sub>h</sub> = Maximum extension length in case of horizontal installation

L<sub>v</sub> = Maximum extension length in case of vertical installation

BB = Width of band, corresponds to L<sub>min</sub>

AF = Inside diameter of the centring flange AD +4 mm

IF = Outside diameter of the centring flange ID -2 mm

## Ordering code spiral spring cover

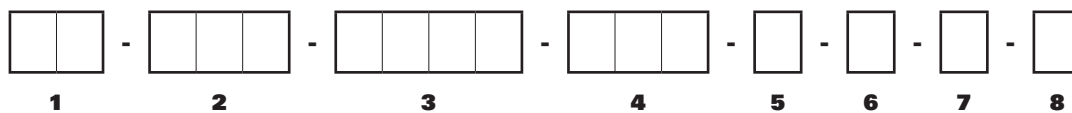

No.	Designation	Code	Description
1	Product abbreviation	<b>SF</b>	
2	ID in [mm]		Inside diameter of the spiral spring +1 mm
3	Largest length L <sub>h</sub> /L <sub>v</sub> in [mm]		Maximum extension length
4	BB / L <sub>min</sub> in [mm]		Width of band, corresponds to L <sub>min</sub>
5	Installation position	<b>H</b>	Horizontal
		<b>V</b>	Vertical
6	Material	<b>B</b>	Standard spring in blue spring steel
		<b>S</b>	Version in rustproof stainless steel
7	Accessories (If using mounting flanges the possible spindle diameter SD is reduced by 6 mm)	<b>0</b>	Without mounting flange
		<b>1</b>	With mounting flange outside (inside diameter +4 mm of outer diameter OD of spiral spring)
		<b>2</b>	With mounting flange inside (inside diameter -2 mm of inner diameter ID of spiral spring)
		<b>3</b>	With mounting flange inside/outside
8	Special requirements for mounting flange	<b>0</b>	None
		<b>1</b>	According to specification, description or drawing

## Lubricants

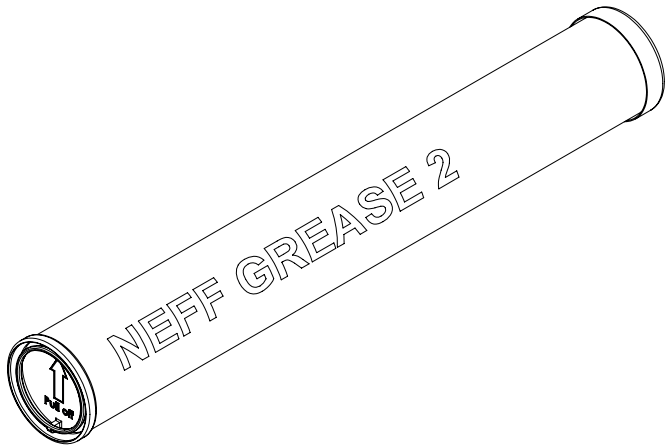

### **NEFF-Grease 2**

Neff Grease 2 was specially developed for use in highly-stressed trapezoidal screw drives, sliding screw drives and worm gear drives.

The heavy-duty grease was specially developed for high surface pressure and has outstanding temperature stability

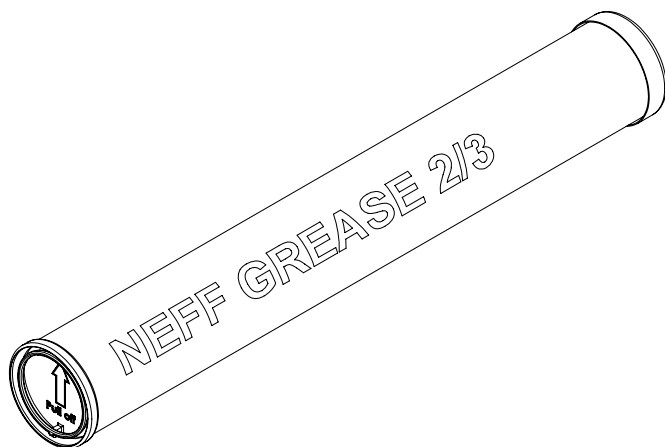

### **NEFF-Grease 2/3**

Neff Grease 2/3 was specially developed for use with highly-stressed ball screw drives.

The strongly adhering synthetic grease containing Teflon has very good temperature stability and can withstand high loads and vibrations.

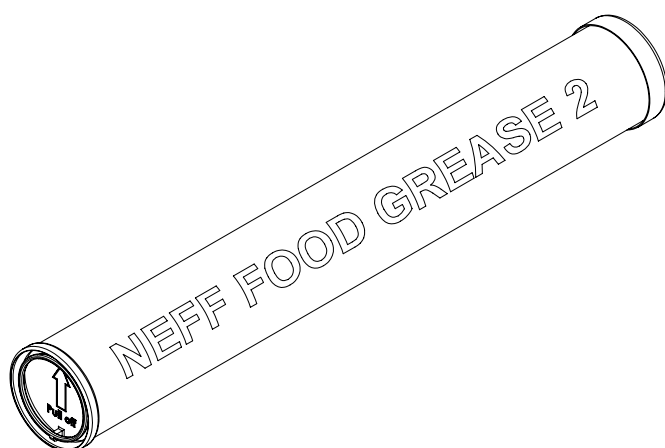

### **NEFF-Food Grease 2**

NEFF Food Grease 2 was specially developed for the requirements of the food industry. The grease meets the requirements of DIN V 10517. Suitable for use in applications with occasional food contact (class NSF-H1).

# NEFF Lubricant dispenser

The NEFF Lube 1 automatic lubricant dispenser is screwed directly onto the lubrication point. It operates independently and is activated when setting the running time. The lubricant level is always visible in the transparent window.

Readjustment during operation is possible.

The shelf life of the lubricant dispenser expires after 2 years.

The NEFF Lube 1 lubricant dispenser is available in 4 sizes:

Size	Contents	Length L	Connection	Grease types	Grease delivery per day	Dispensing period
NEFF LUB 1-30	30ml	43mm	R ¼ inch	All standard NEFF Grease types	0.08–8.3 ml	1-12 month
NEFF LUB 1-60	60ml	62mm				
NEFF LUB 1-125	125ml	100mm				
NEFF LUB 1-250	250ml	192mm				

When ordering in conjunction with a ball screw or trapezoidal screw drive, please indicate special requirements of the nut in the ordering code.

Caution: when the lubricant dispenser is mounted the overall height of the NEFF LUB 1 is increased by about 25 mm due to the connecting/adaptor piece

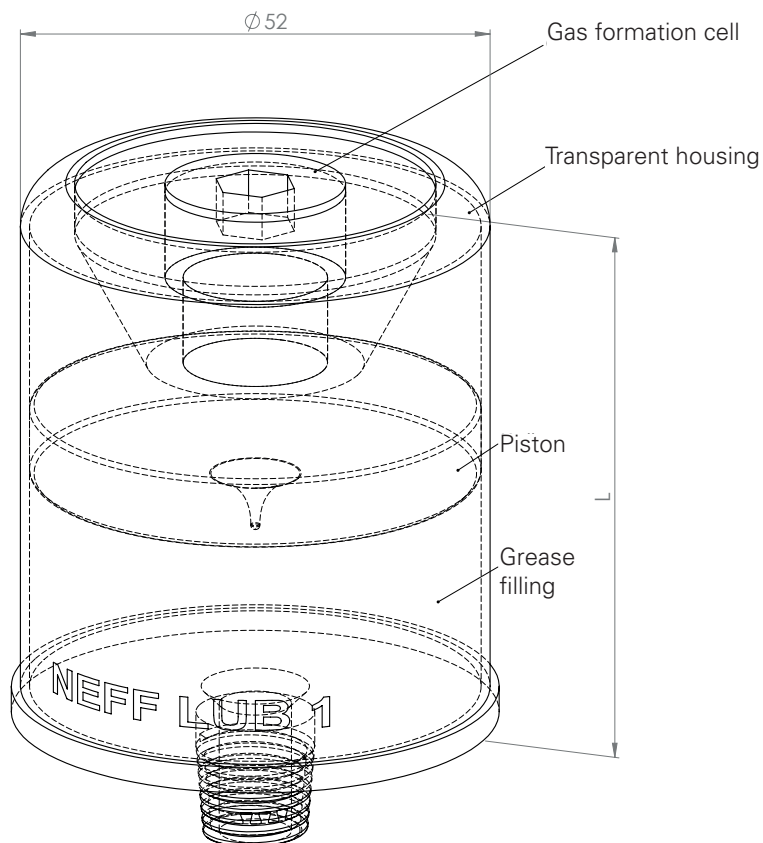

# 3-phase motors M

3-phase 4-pole motors (1500 rpm) in totally enclosed fan-cooled designs in accordance with VDE 0530 Part 1.

Standard protection class: IP55. Temperature class F. Other SEW motors on enquiry.

Notes: If the free shaft end of the motor is used as shaft for a slip-on emergency hand wheel, a device will be required that interrupts the power supply before the crank engages. Motors with different speeds and brake motors on enquiry.

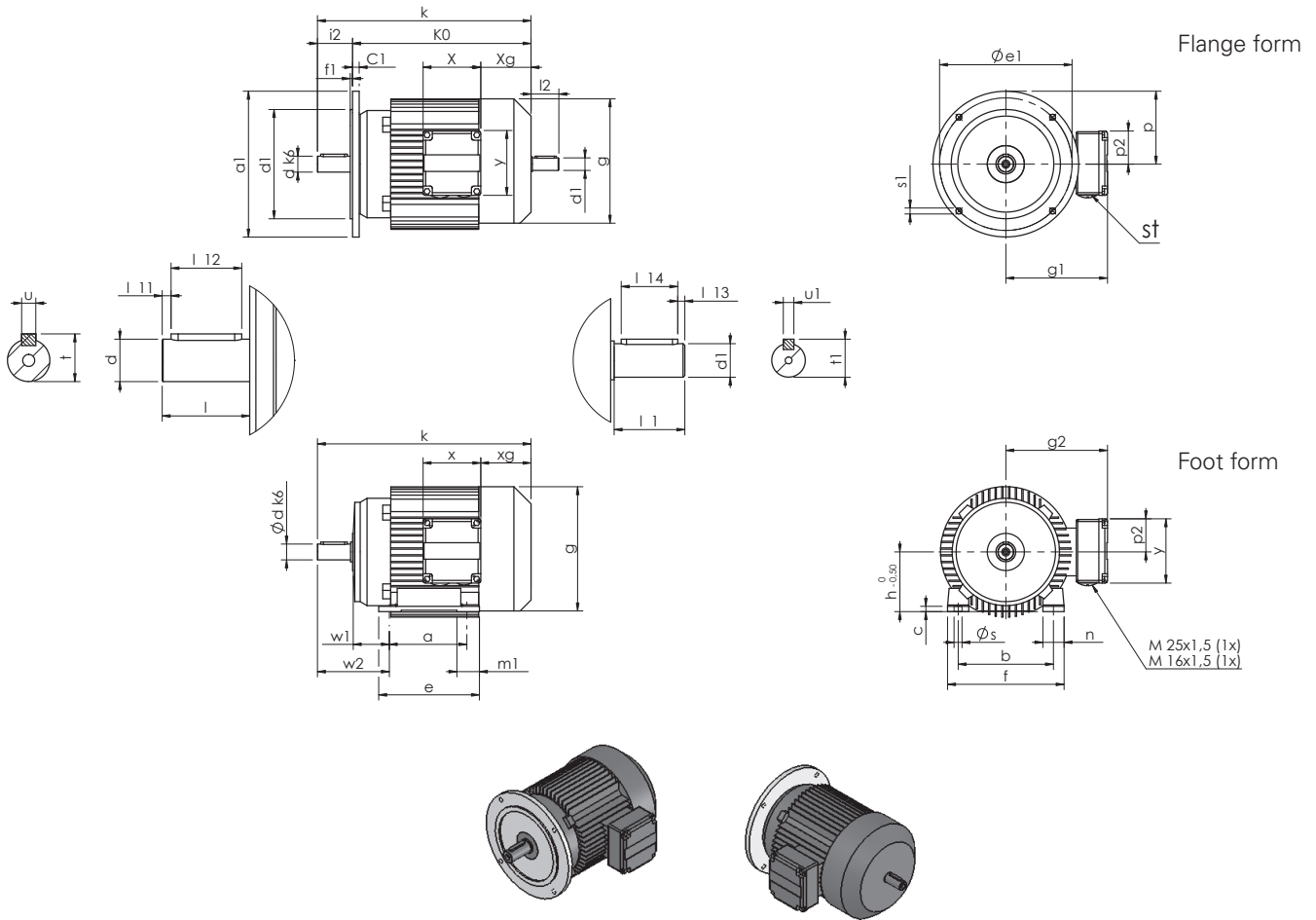

## Performance data

Size	Nominal power [kW]	Nominal speed [rpm]	Power factor $\cos \varphi$	Nominal current at 400 V [A]	Rel. starting current $I_A/I_N$	Nominal torque [Nm]	Rel. starting torque $M_A/M_N$	Rel. run-up torque $M_H/M_N$	Moment of inertia $J_{Mot}$ [ $10^{-4} \text{kgm}^2$ ]	Moment of inertia $J_{Bremsmot}$ [ $10^{-4} \text{kgm}^2$ ]	Braking torque [Nm]
DT71K4	0.15	1380	0.67	0.61	2.9	1.0	1.8	1.7	4.6	5.5	5.0
DT71C4	0.25	1380	0.70	0.80	2.8	1.7	1.8	1.7	4.6	5.5	5.0
DT71D4	0.37	1380	0.76	1.15	3.0	2.6	1.8	1.7	4.6	5.5	5.0
DT80K4	0.55	1360	0.72	1.75	3.4	3.9	2.1	1.8	7.5	7.5	10
DT80N4	0.75	1380	0.73	2.1	3.8	5.2	2.2	2.0	8.7	9.6	10
DT90S4	1.1	1400	0.77	2.8	4.3	7.5	2.0	1.9	25	31	20
DT90L4	1.5	1410	0.78	3.55	5.3	10.2	2.6	2.3	34	40	20
DV100M4	2.2	1410	0.83	4.7	5.9	15.0	2.7	2.3	53	59	40
DV100L4	3.0	1400	0.83	6.3	5.6	20.5	2.7	2.2	65	71	40
DV112M4	4.0	1420	0.84	8.7	5.4	26.9	2.4	2.1	98	110	55

# 3-phase motors M

## Dimensions

The values in brackets refer to motors with brake.

## Flange shape

Size	Dimensions [mm]													
	a <sub>1</sub>	b <sub>1</sub>	c <sub>1</sub>	d	d <sub>1</sub>	e <sub>1</sub>	f <sub>1</sub>	g	g <sub>1</sub>	i <sub>2</sub>	k	k <sub>0</sub>	l	l <sub>11</sub>
DFT71K4	120	80	8	14	11	100	3	145	122(127)	24	232 (296)	208 (296)	30	4
DFT71C4	120	80	8	14	11	100	3	145	122(127)	24	232 (296)	208 (272)	30	4
DFT71D4	120	80	8	14	11	100	3	145	122(127)	24	232 (296)	208 (272)	30	4
DFT80K4	120	80	8	19	14	100	3	145	122(127)	34	292 (356)	258 (322)	40	4
DFT80N4	120	80	8	19	14	100	3	145	122(127)	34	292 (356)	258 (322)	40	4
DFT90S4	160	110	10	24	19	130	3.5	197	154(161)	53.5	323 (408)	273 (358)	50	5
DFT90L4	160	110	10	24	19	130	3.5	197	154(161)	53.5	323 (408)	273 (358)	50	5
DFV100M4	200	130	10	28	19	165	3.5	197	166	60	371 (456)	311 (396)	60	5
DFV100L4	200	130	10	28	19	165	3.5	197	166	60	401 (486)	341 (426)	60	5
DFV112M4	200	130	11	28	24	165	3.5	221	179(182)	64	409 (489)	345 (425)	60	5

Size	Dimensions [mm]													
	l <sub>12</sub>	l <sub>1</sub>	l <sub>2</sub>	l <sub>13</sub>	l <sub>14</sub>	s <sub>1</sub>	t	u	t <sub>1</sub>	u <sub>1</sub>	x	x <sub>g</sub>	y	p <sub>2</sub>
DFT71K4	22	23	24	1	20	6.6	16	5	12.5	4	87 (127)	61 (86)	97	50
DFT71C4	22	23	24	1	20	6.6	16	5	12.5	4	87 (127)	61 (86)	97	50
DFT71D4	22	23	24	1	20	6.6	16	5	12.5	4	87 (127)	61 (86)	97	50
DFT80K4	32	30	31	4	22	6.6	21.5	6	16	5	87 (127)	61 (86)	97	50
DFT80N4	32	30	31	4	22	6.6	21.5	6	16	5	87 (127)	61 (86)	97	50
DFT90S4	40	40	42	4	32	9	27	8	21.5	6	87 (127)	76 (121)	97	50
DFT90L4	40	40	42	4	32	9	27	8	21.5	6	87 (127)	76 (121)	97	50
DFV100M4	50	40	42	4	32	11	31	8	21.5	6	106 (139)	74 (125)	109	56
DFV100L4	50	40	42	4	32	11	31	8	21.5	6	106 (139)	74 (125)	109	56
DFV112M4	50	50	55	5	40	11	31	8	27	8	106 (139)	91 (131)	109	56

## Foot shape

Size	Dimensions [mm]											
	a	b	c	e	f	h	m <sub>1</sub>	n	s	w <sub>1</sub>	w <sub>2</sub>	
DT71K4	90	112	5	115	144	71	32	31	7	45	75	
DT71C4	90	112	5	115	144	71	32	31	7	45	75	
DT71D4	90	112	5	115	144	71	32	31	7	45	75	
DT80K4	100	125	10	125	149	80	28	33	9	50	90	
DT80N4	100	125	10	125	149	80	28	33	9	50	90	
DT90S4	125	140	8	152	176	90	32	32	9	56	106	
DT90L4	125	140	8	152	176	90	32	32	9	56	106	
DV100M4	140	160	12	170	188	100	35	38	12	63	123	
DV100L4	140	160	12	170	188	100	35	38	12	63	123	
DV112M4	140	190	14	170	220	112	35	44	12	70	130	

# Handwheels HR

Handwheel HR for the emergency adjustment and manual adjustment of worm gear screw jacks or systems.

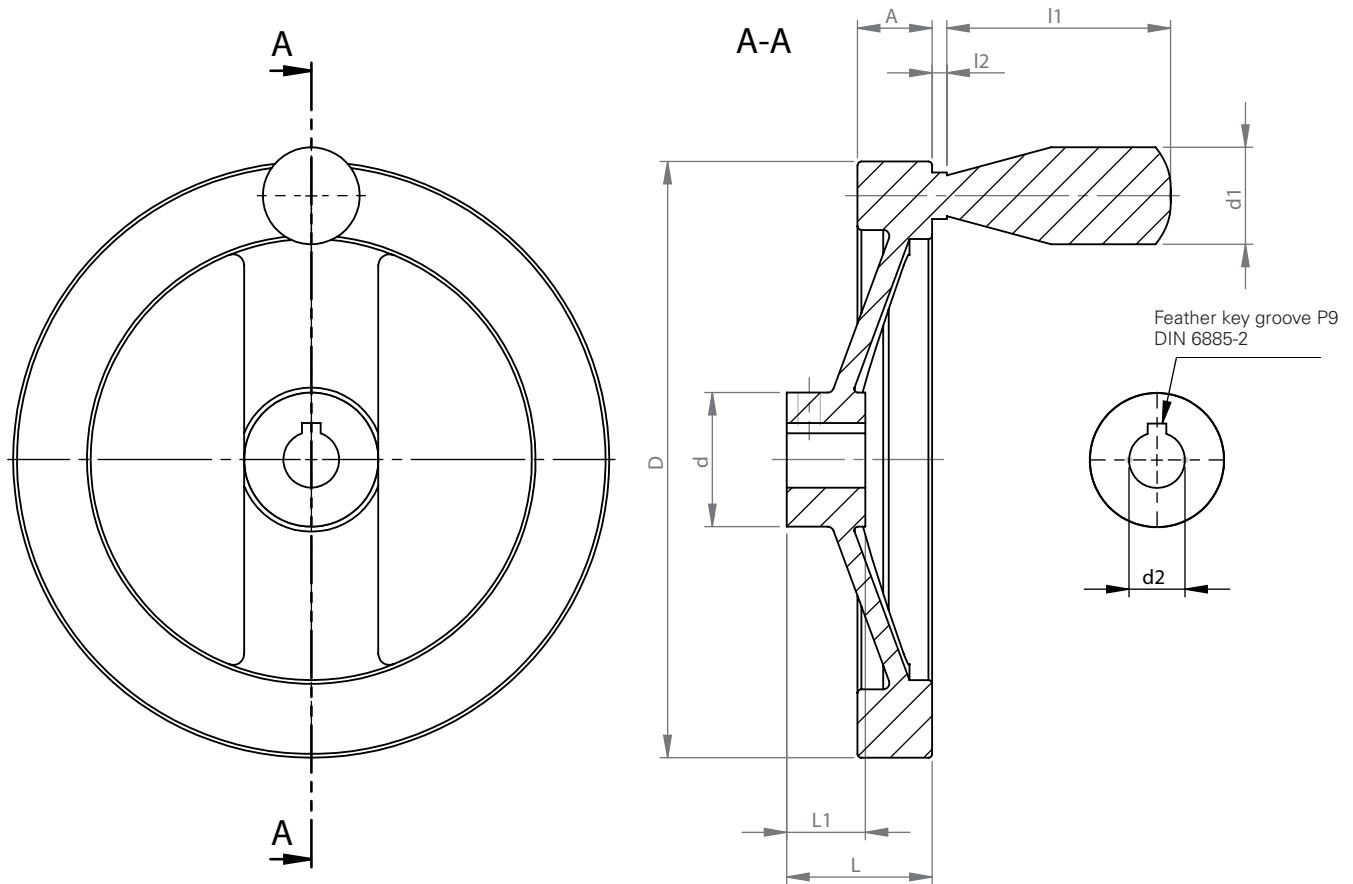

Size	Dimensions in [mm]								Bore d2 H7
	A	D	d	d1	L1	L	l1	l2	
HR 80	10	80	31	21	16	29	50	2.5	Ø 10
HR 80	10	80	31	21	16	29	50	2.5	Ø 14
HR 100	10	100	33	21	17	33	50	2.5	Ø 10
HR 100	10	100	33	21	17	33	50	2.5	Ø 14
HR 125	13	125	35	22	18	36	56	2.5	Ø 10
HR 125	13	125	35	22	18	36	56	2.5	Ø 14
HR 140	13	140	37	22	19	39	56	2.5	Ø 14
HR 140	13	140	37	22	19	39	56	2.5	Ø 16
HR 160	16	160	40	23	20	40	65	2.5	Ø 14
HR 160	16	160	40	23	20	40	65	2.5	Ø 16
HR 200	16	200	45	26	24	45	80	2.5	Ø 16
HR 200	16	200	45	26	24	45	80	2.5	Ø 20
HR 250	19	250	52	31	28	50	102	2.5	Ø 20
HR 250	19	250	52	31	28	50	102	2.5	Ø 25

# Safety handwheels SHR

Safety handwheel SHR for the emergency adjustment and manual adjustment of worm gear screw jacks or systems. Safety handwheels decouple themselves to prevent turning with the spindle. Standstill of the handwheel is guaranteed only up to medium speeds.

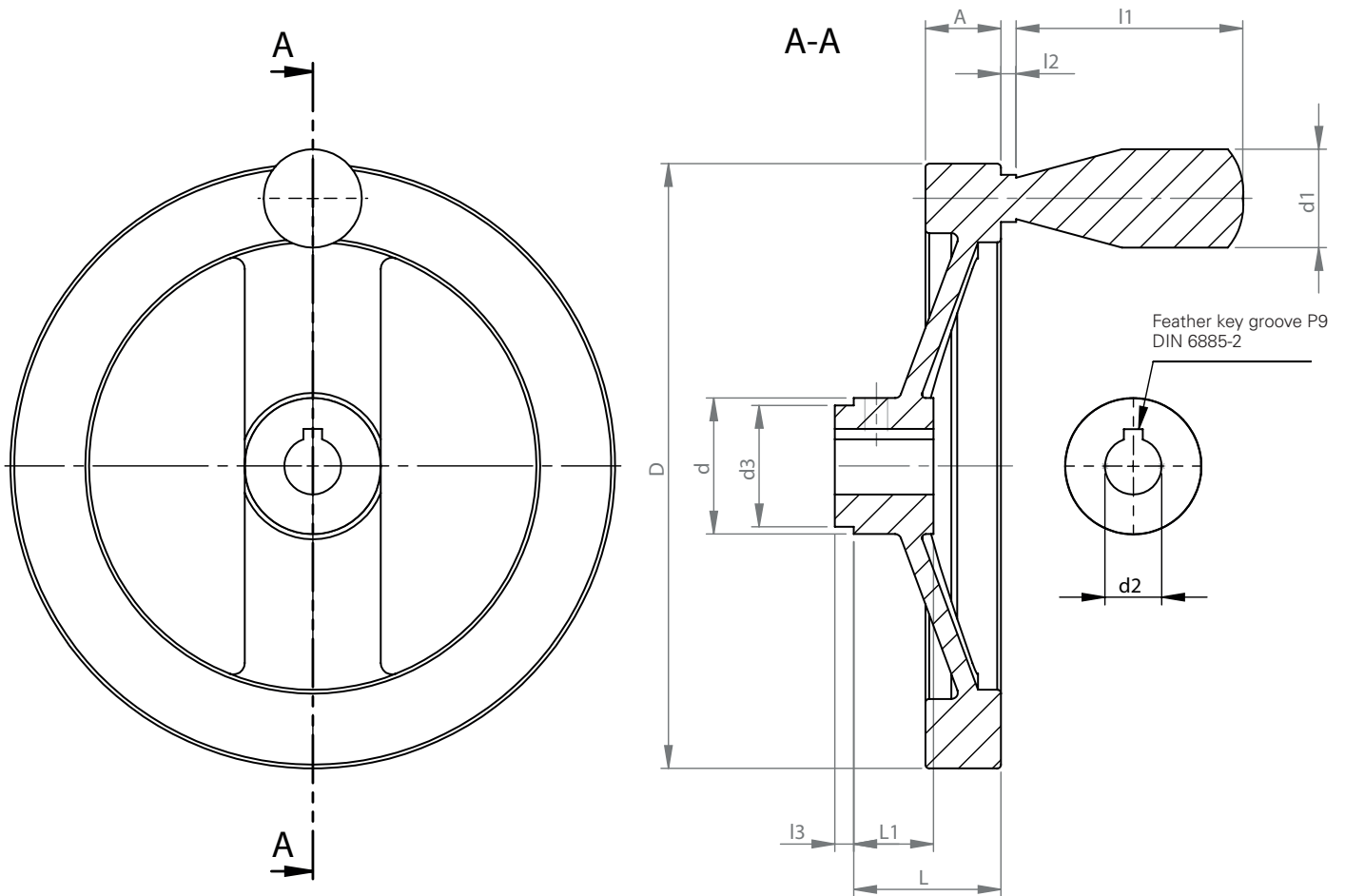

Size	Dimensions in [mm]										Bore d2 H7
	A	D	d	d1	d3	L	L1	l1	l2	l3	
HR 125	13	125	35	22	28	36	18	56	2.5	5	Ø 14
HR 140	13	140	37	22	28	39	19	56	2.5	5	Ø 14
HR 140	13	140	37	22	28	39	19	56	2.5	5	Ø 16
HR 160	16	160	40	23	32	40	20	65	2.5	6	Ø 14
HR 160	16	160	40	23	32	40	20	65	2.5	6	Ø 16
HR 200	16	200	45	26	38	45	24	80	2.5	6	Ø 18
HR 200	16	200	45	26	38	45	24	80	2.5	6	Ø 20
HR 250	19	250	52	31	45	50	28	102	2.5	12	Ø 22



# Motor adaptor flanges MG

Motor adaptor flanges are used to mount motors to worm gear screw jacks and house the coupling for connecting the motor to the drive shaft.

When ordering, please specify the side at which the motor adaptor flange is to be attached (A or B).

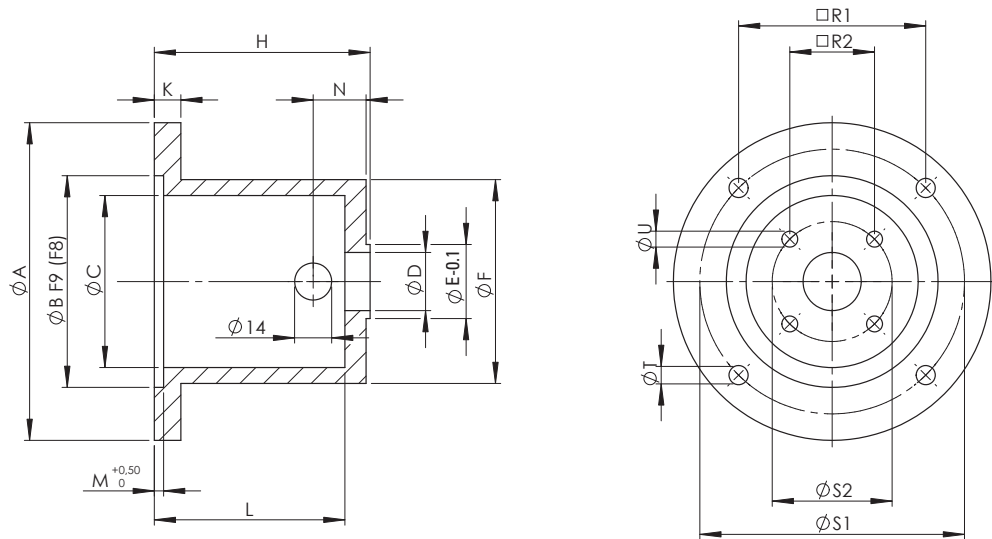

Size	Motor	Version MG/ZF <sup>1)</sup>	Dimensions [mm]									
			A	B	C	D	E	Ø F	□ F	H	I	K
MG M 0	DFT63	MG	90	60	44	19	22	50		62	61	10
MG M 1	DFT71	MG	120	80	65	22	32	77		81.5	80	10
MG M 1	DFT80	MG	120	80	56	22	32	62		91.5	90	10
MG M 2	DFT71	MG	120	80	65	26	35	77		81.5	80	10
MG M 2	DFT80	MG	120	80	78	26	35	88		92.5	91	10
MG M 2	DFT90	MG	160	110	90	31	35	110		109.5	108	15
MG M 3	DFT71	MG	120	80	77	28	40	87		91.5	90	10
MG M 3	DFT80	MG	120	80	78	28	40	88		103	101	10
MG M 3	DFT90	MG	160	110	95	28	40	104		125	123	12
MG M 3	DFV100/112	MG + ZF	200	130	100	24	35	145		133	131	29
MG M 4	DFT80	MG	120	80	75	42	52	–	88	105	103	12
MG M 4	DFT90	MG	160	110	98	42	52	114		118	116	15
MG M 4	DFV100/112	MG + ZF	200	130	120	30	52	145		134	131	29
MG M 5	DFT90	MG	160	110	105	45	62	120		138.5	136	15
MG M 5	DFV100/112	MG	200	130	125	35	62	145		154	152	16

<sup>1)</sup> MG = Motor adaptor flange  
ZF = Intermediate flange

# Motor adaptor flanges MG

Motor adaptor flanges are used to mount motors to worm gear screw jacks and house the coupling for connecting the motor to the drive shaft.

When ordering, please specify the side at which the motor adaptor flange is to be attached (A or B).

Dimensions [mm]									Coupling Size	Coupling half <sup>1)</sup> M	Coupling half <sup>1)</sup> Motor
L	M	N	□ R <sub>1</sub>	□ R <sub>2</sub>	S <sub>1</sub>	S <sub>2</sub>	T	U			
53	3	20	53	24	75	33.9	6	5.5	RA14	RA14 Ø9	RA14 Ø11
72	3.5	20	70.7	32	100	45.3	6.6	5.5	RA19	RA19 Ø10	RA19 Ø14
85	3.5	20	70.7	32	100	45.3	6.6	5.5	RA19	RA19 Ø10	RA19 Ø19
73	3.5	22	70.7	35	100	49.5	6.6	6.6	RA19	RA19 Ø14	RA19 Ø14
84	3.5	22	70.7	35	100	49.5	6.6	6.6	RA19	RA19 Ø14	RA19 Ø19
100	4	27	92	35	130	49.5	9	6.6	RA24	RA24 Ø14	RA24 Ø24
83	3.5	27	70.7	44	100	62.2	6.6	9	RA19	RA19 Ø16	RA19 Ø14
93	3.5	32	70.7	44	100	62.2	6.6	9	RA19	RA19 Ø16	RA19 Ø19
114	4	30	92	44	130	62.2	9	9	RA24	RA24 Ø16	RA24 Ø24
119	4.5	40	116.7	44	165	62.2	M10	9	RA28	RA28 Ø16	RA28 Ø28
94	3.5	35	70.7	55	100	78	6.6	11	RA24	RA24 Ø20	RA24 Ø19
106	4	30	92	55	130	78	M8	11	RA24	RA24 Ø20	RA24 Ø24
119	4.5	38	116.7	55	165	78	M10	11	RA28	RA28 Ø20	RA28 Ø28
122	4	48	92	70	130	99	M8	13.5	RA28	RA28 Ø25	RA28 Ø24
138	7	50	116.7	70	165	99	M10	13.5	RA28	RA28 Ø25	RA28 Ø28

<sup>1)</sup>When ordering, the bore diameter of the coupling half on the motor side must be explicitly stated.

## Ordering code for motor adaptor flange MG

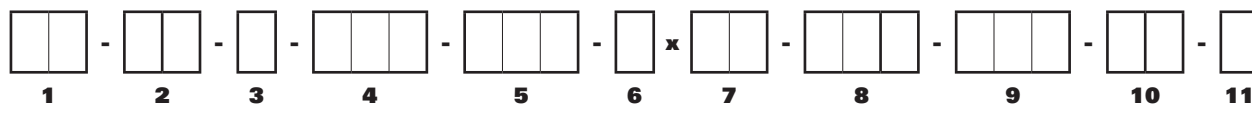

No.	Designation	Code	Description
1	Product abbreviation	<b>MG</b>	
2	Gear designation	<b>M1, M2,...</b>	Sequential sizes – worm gear screw jacks
		<b>J1, J2, ...</b>	Sequential sizes – worm gear screw jacks
		<b>G1, G2, ...</b>	Sequential sizes – high-speed screw jacks
3	Version	<b>R</b>	Round
		<b>V</b>	Square
4	Centring diameter of motor flange in [mm]		
5	Outside diameter of motor flange in [mm]		
6	Number of pitch circle bores		Number of bores on the motor flange
7	Size/thread size of the pitch circle bores		e.g. 6.5 for 6.5 mm diameter (flange form B14) e.g. M6 for a M6 thread (flange form B5)
8	Pitch circle diameter of motor flange in [mm]		
9	Length without bearing centring attachment in [mm]		Determined by length of the shaft extension and dimension B of the coupling
10	Material	<b>AL</b>	Aluminium alloy
		<b>ZI</b>	Zinc-phosphated steel
		<b>A2</b>	Rust-resistant
		<b>A4</b>	Rust, acid and seawater-resistant
11	Special requirements	<b>0</b>	None
		<b>1</b>	According to specification, description or drawing

# Couplings

## Shaft couplings GS

The GS shaft coupling is a special anti backlash shaft coupling.

The toothed ring is installed under pre-tension, resulting in a low surface pressure and hence increased rigidity of the system.

This shaft coupling has proved itself due to its flawless function and durability at high speeds and under strong acceleration.

We recommend this shaft coupling with clamping hub or clamping ring hub.

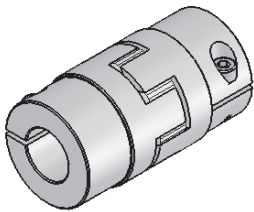
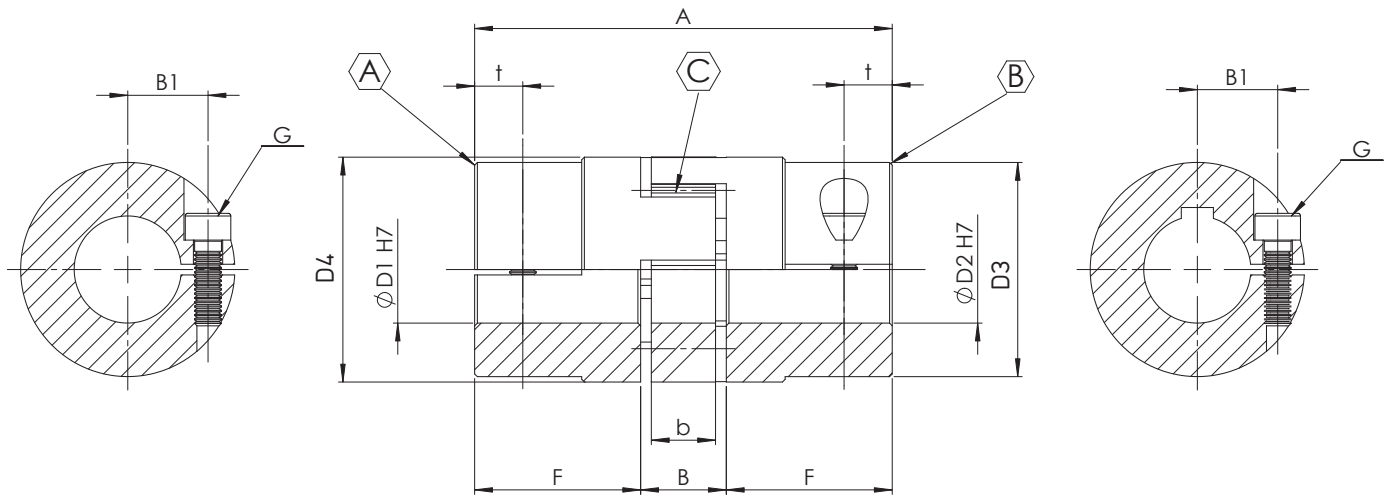

Size	$D_1 H7$	$D_2 H7$	$D_3$	$D_4$	A	F	t	b	B	$B_1$	G
WK-GS-9	6-9	6-9	20	23.5	30	10	5	8	10	7.5	M2
WK-GS-14	6-14	6-14	30	32.5	35	11	5	10	13	11.5	M3
WK-GS-19	10-20	10-20	40	46	66	25	12	12	16	14.5	M6
WK-GS-24	10-28	10-28	55	57	78	30	14	14	18	14.5	M6
WK-GS-28	19-38	19-39	65	72.6	90	35	15	15	20	20	M8

# Couplings

Version 1

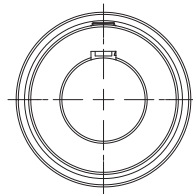
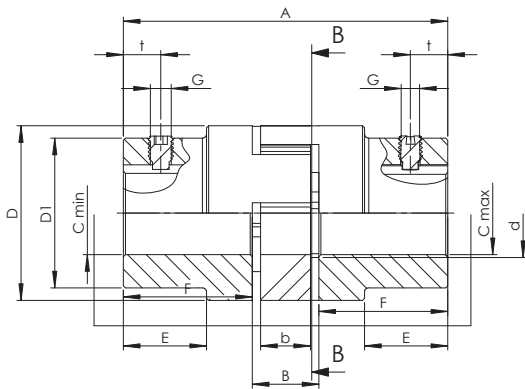

## Shaft couplings RA, RG

The RA or RG shaft couplings are particularly torsionally flexible. They compensate smaller angular, radial and axial shaft displacements.

They protect worm gear screw jacks, bevel gearboxes and motors thanks to their shock and vibration damping effect.

Version 1a

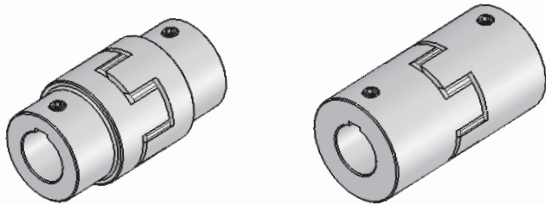
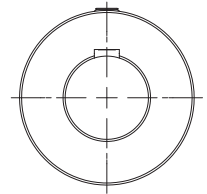
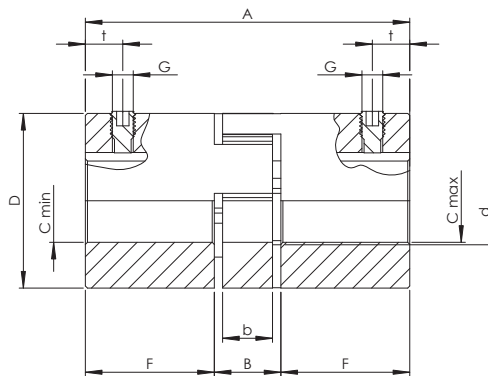

Size	Version	Max. $M_d$ [Nm]	Dimensions [mm]										Offsets				Locking screw		Weight [kg]
			$A_1$	E	F	B	b	$D_1$	D	d	$C_{min}^{1)}$	$C_{max}^{1)}$	max. axial displacement $\Delta K_a$ [mm]	max. radial non-alignment $n=1500$ 1/min. $\Delta K_r$ [mm]	max. angular displacement bei $n=1500$ 1/min. $\Delta K_w$ [Grad]   $\Delta K_w$ [mm]		Dim.	Dim.	
RA 14	1a	7,5	35	–	11	13	10	–	30	10	6	15	1,0	0,17	1,2	0,67	M4	5	0,05
RA 19	1	10	66	20	25	16	12	32	40	18	10	19	1,2	0,20	1,2	0,82	M5	10	0,15
RA 19	1a	10	66	–	25	16	12	–	41	18	19	24	1,2	0,20	1,2	0,82	M5	10	0,15
RA 24	1	35	78	24	30	18	14	40	55	27	14	24	1,4	0,22	0,9	0,85	M5	10	0,25
RA 24	1a	35	78	–	30	18	14	–	56	27	22	28	1,4	0,22	0,9	0,85	M5	10	0,35
RA 28	1	95	90	28	35	20	15	48	65	30	14	28	1,5	0,25	0,9	1,05	M6	15	0,40
RA 28	1a	95	90	–	35	20	15	–	67	30	28	38	1,5	0,25	0,9	1,05	M6	15	0,55
RG 38	1	190	114	37	45	24	18	66	80	38	16	38	1,8	0,28	1,0	1,35	M8	15	0,85
RG 42	1	265	126	40	50	26	20	75	95	46	28	42	2,0	0,32	1,0	1,70	M8	20	1,2
RG 48	1	310	140	45	56	28	21	85	105	51	28	48	2,1	0,36	1,1	2,00	M8	20	1,7
RG 55	1	410	160	52	65	30	22	98	120	60	30	55	2,2	0,38	1,1	2,30	M10	20	7,3
RG 65	1	625	185	61	75	35	26	115	135	68	40	65	2,6	0,42	1,2	2,70	M10	20	11,0
RG 75	1	975	210	69	85	40	30	135	160	80	40	75	3,0	0,48	1,2	3,30	M10	25	17,9
RG 90	1	2400	245	81	100	45	34	160	200	100	50	90	3,4	0,50	1,2	4,30	M12	30	28,5

<sup>1)</sup> This catalogue does not list all intermediate sizes.  
Further sizes on enquiry.

The threaded bore G for the locking screw is located opposite the feather key groove.

# Universal joint shaft ZR

The ZR universal joint shaft is particularly torsionally flexible and serves to bridge large shaft distances at rotary speeds of up to 1500 rpm. Thanks to the double arrangement of the toothed rings, large radial displacements are possible with good damping characteristics. The ZR universal joint shaft can be mounted radially without shifting the gearbox or the motor.

Selection B-B

Selection A-A

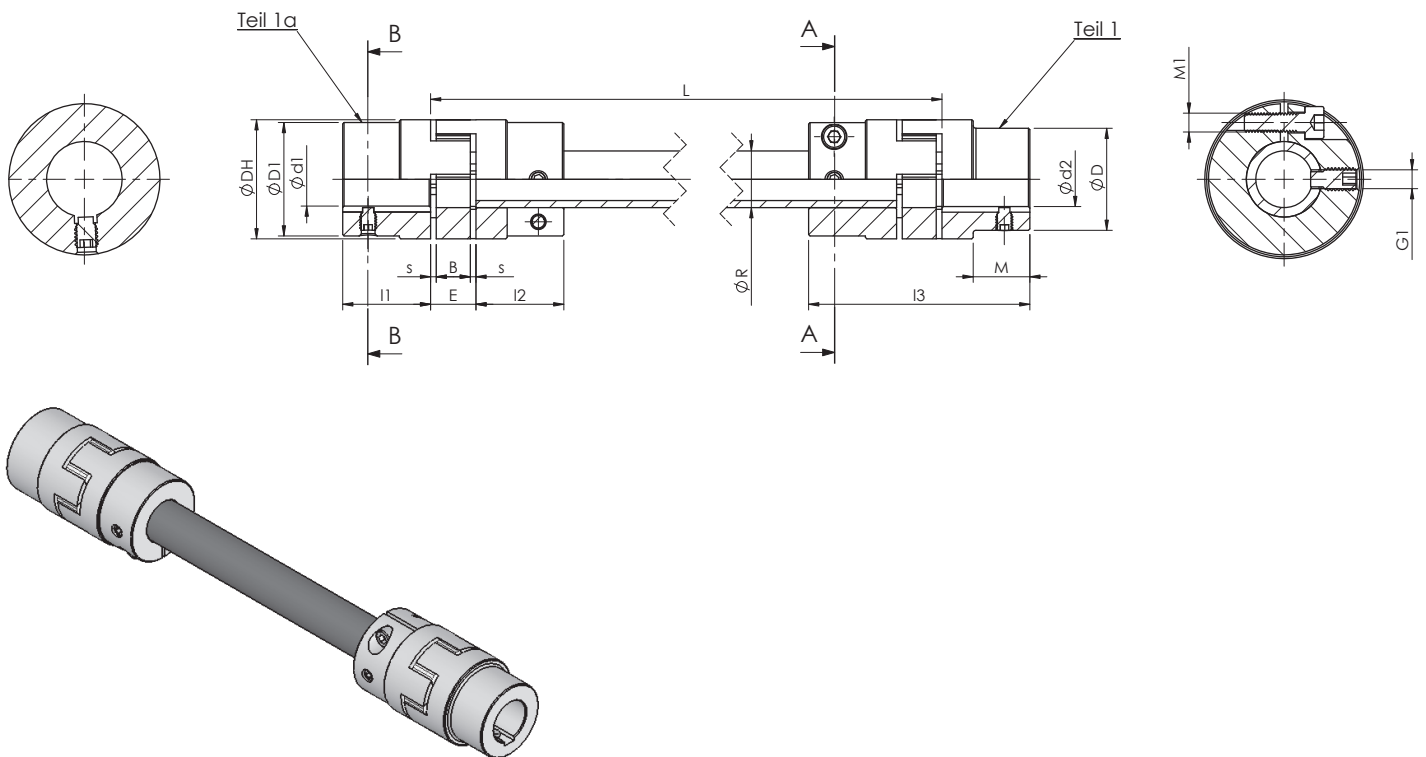

Size	Manufacturing bore $\varnothing dH7^{2)}$		$\varnothing DH$	$\varnothing D$	$\varnothing D1$	$\varnothing dH$	$I1$	$I2$	$M$	$s$	$b$	$E$	$I3$	$\varnothing R$	$G1$	$dp$	
	Part 1 min $\varnothing d2$	Part 1a max $\varnothing d1$															
ZR 14	-	-	4	14	30	-	30	10.5	11	-	1.5	10	13	35	14x2	M4	2.5
ZR 19	6	19	19	24	40	32	41	18	25	20	2	12	16	66	20x3	M6	4
ZR 24	8	24	24	28	55	40	55	27	30	24	2	14	18	78	30x4	M8	5.5
ZR 28	10	28	28	38	65	48	65	30	35	28	2.5	15	20	90	35x4	M10	7
ZR 38	12	38	38	45	80	66	77	38	45	37	3	18	24	114	40x4	M12	8.5
ZR 42	28	42	42	55	95	75	94	46	50	40	3	20	26	126	45x4	M12	8.5
ZR 48	28	48	48	60	105	85	102	51	56	45	3.5	21	28	140	50x4	M16	12

# Universal joint shaft GX

Torsionally rigid universal joint shafts are used to connect several worm gear screw jacks. The shafts attenuate noise, vibrations and impacts and compensate for axial, radial and angular errors. They offer exceptional torsional rigidity, high temperature and oil resistance and are particularly suitable where long lengths and/or high speeds are required. Elastic universal joint shafts are maintenance-free; the central section can be removed radially (to the side) without axial displacement of the connected units.

They are supplied as a length of tube (dimension L to be specified by customer) fitted with coupling assemblies at both ends. Pedestal bearings are generally not required, except for very long connections. For optimum alignment of the screw jacks, we recommend the use of universal joint shafts with clamping sets

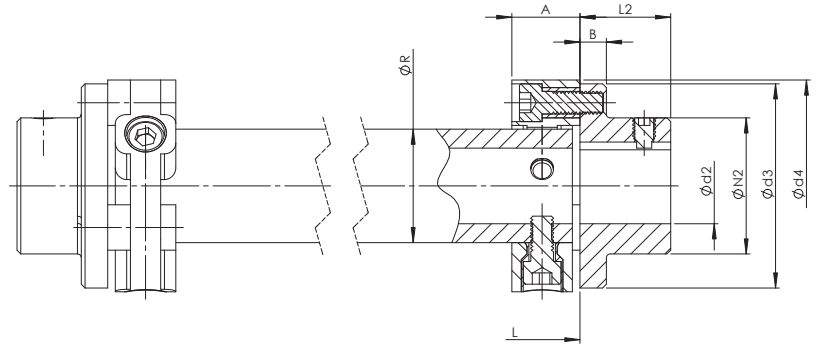
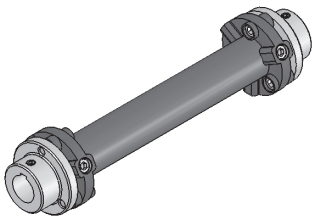

Size	A	B	C	$\varnothing d_3$	Pilot hole d	Manufacturing bore $\varnothing dH7 2$ D max <sup>(2)</sup>	E	F	L <sub>2</sub>	$\varnothing N_2$	$\varnothing R$	T	T <sub>k</sub> / M
GX - 1	24	7	5	56	8	25	22	2	24	36	30	1.5	Ø44/2xM6
GX - 2	24	8	5	85	12	38	20	4	28	55	40	1.5	Ø68/2xM8
GX - 4	28	8	5	100	15	45	24	4	30	65	45	1.5	Ø80/3xM8
GX - 8	32	10	5	120	18	55	28	4	42	80	60	1.5	Ø100/3xM10
GX - 16	42	12	5	150	20	70	36	6	50	100	70	1.5	Ø125/3xM12
GX - 25	46	14	5	170	20	85	40	6	55	115	85	1.5	Ø140/3xM14
GX - 30	58	16	5	200	25	100	50	8	66	140	100	1.5	Ø165/3xM16
GX - 50	58	16	5	200	25	100	50	8	66	140	100	1.5	Ø165/3xM16
GX - 90	70	19	5	260	30	110	62	8	80	160	125	2	Ø215/3xM20

## Universal joint shaft diagram

as a function of length and speed

permissible speed = speed of rotation \* 0,8

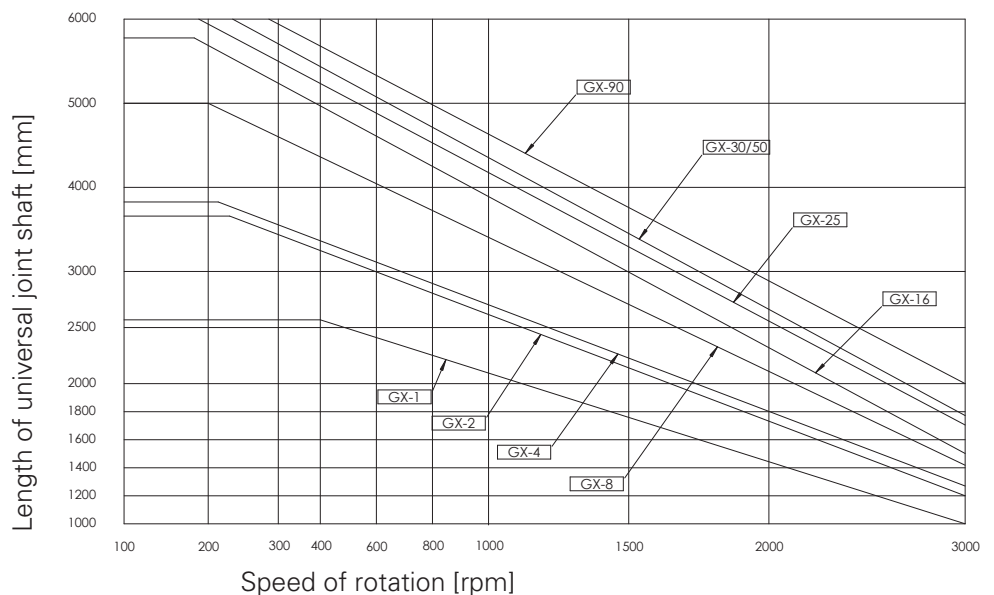

**Universal joint shaft GX**  
 Length of the universal joint shaft for  
 screw jacks M with feather key groove

**M 0**

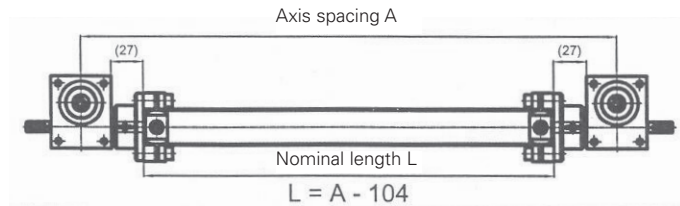

**M 1**

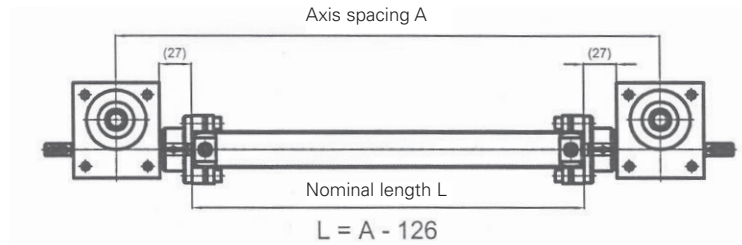

**M 2**

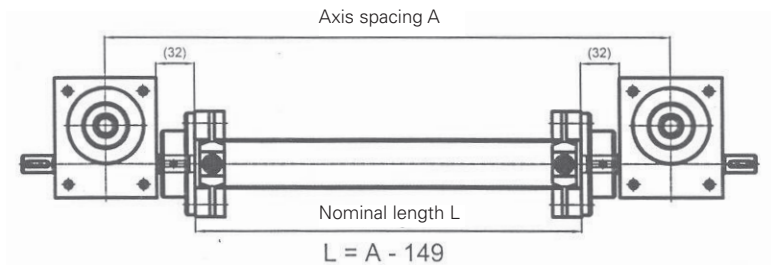

**M 3**

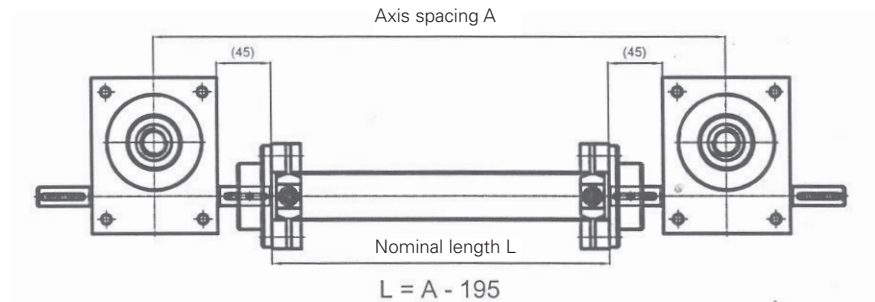

**M 4**

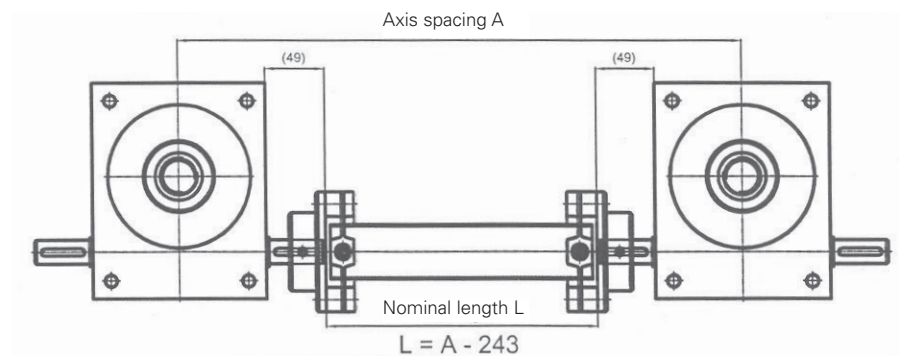

**M 5**

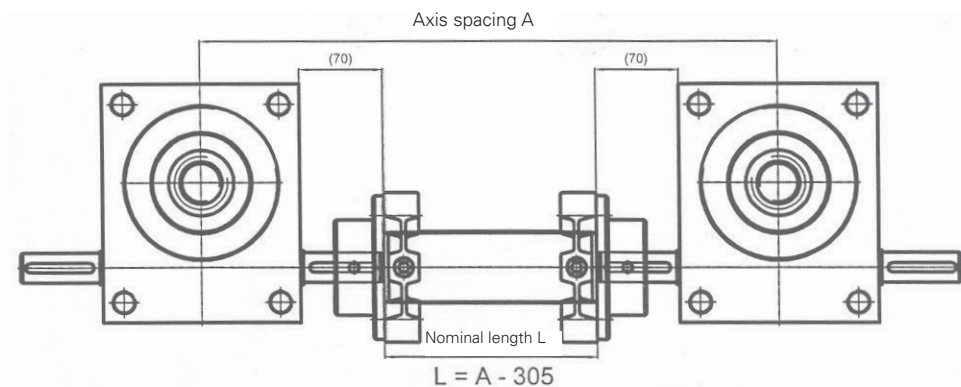

# Pedestal bearings SN

The pedestal bearings conforming to DIN 736 come complete with roller bearing, retaining bush and case with felt seals on both sides. These pedestal bearings are very well suited to the intermediate support of our GX and ZR universal joint shafts when these are very long. The retaining bush can be fixed to the outer diameter of the tube. The pedestal bearing is supplied as a movable bearing if nothing in particular is specified.

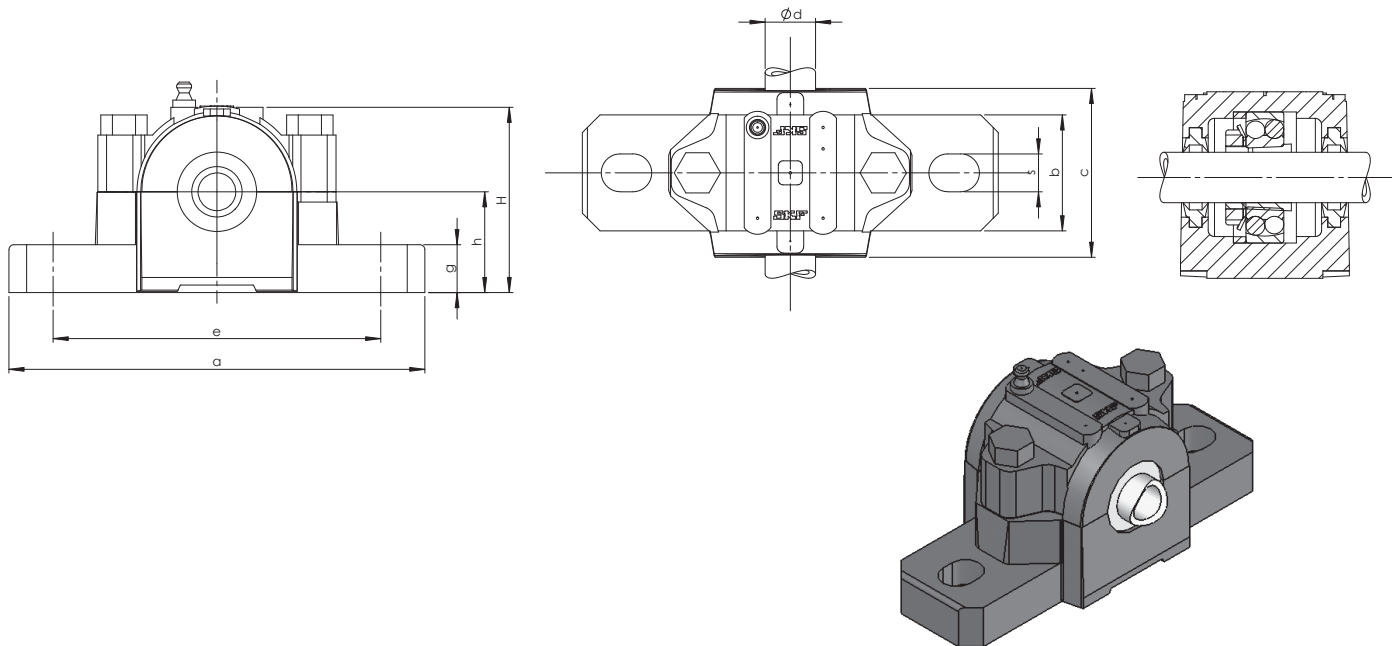

Size	Ø d	H	h	e	S	C	a	b	g (max)	Weight kg
SN 505-20	20	75	40	130	15	67	165	46	19	1.4
SN 506-25	25	90	50	150	15	77	185	52	22	1.98
SN 507-30	30	110	50	150	15	82	185	52	22	2.1
SN 508-35	35	110	60	170	15	85	205	60	25	3.1
SN 509-40	40	115	60	170	15	85	205	60	25	2.9
SN 510-50	50	130	60	170	15	90	205	60	25	3.3
SN 511-55	55	135	70	210	18	95	255	70	28	4.6
SN 512-60	60	150	70	210	18	105	255	70	30	5.4
SN 513-65	65	155	80	230	18	110	275	80	30	6.7
SN 515-70	70	175	80	230	18	115	280	80	30	7.3
SN 516-75	75	185	95	260	22	120	315	90	32	9.3
SN 517-80	80	195	95	260	22	125	320	90	32	9.8
SN 518-90	90	215	100	290	22	145	345	100	35	12.5
SN 520-100	100	240	112	320	26	160	380	110	40	15.5
SN 522-110	110	270	125	350	26	175	410	120	45	19.8



# Bevel gearboxes Selection criteria

NEFF bevel gearboxes have strong grey cast iron housings, hardened bevel gears lapped in pairs with spiral toothing and adequately dimensioned roller bearings. Spiral bevel gears offer the decisive advantage of very favourable engagement ratios (high degree of overlap).

Consequently they are predestined for use under high stresses, coupled with optimum smooth running characteristics and high transmission accuracy.

The arc-shaped teeth are more resistant to bending than straight or diagonal teeth. A further advantage is the relative insensitivity to elastic deformation of gear wheels, shafts and bearings.

The gears can therefore also transmit extreme shock loads.

Three standard designs are available. 22 further variations are possible as auxiliary drives. The gearboxes can be used in all installation positions and provided with various mounting holes. Cover and flanges are generally provided with mounting holes.

## Transmission ratios

The following standard transmission ratios are available: 1:1, 1.5:1, 2:1, 3:1, 4:1, 5:1 and 6:1.

All transmission ratios are mathematically precise. The gearboxes can be used as step-up and step-down gearboxes.

Custom transmission ratios are available. Please enquire.

## Efficiency

The efficiency of the NEFF bevel gearboxes is 94 – 98 %, depending on speed, installation position, sealing and type of lubricant. The efficiencies refer to the rated performances of the gearboxes.

In certain installation positions the bevel gears are fully immersed into the lubricant. In case of larger gearboxes and high peripheral speeds of the gear wheels, the churning losses cannot be neglected and NEFF must be consulted.

Note that the start-up efficiency is always smaller than the operational efficiency. The resultant increased breakaway torque must be considered in the design of the drive performance.

## Low-backlash version

As standard the bevel gearboxes have a circumferential backlash of 10 to 30 angular minutes, depending on the size of the transmission and the transmission ratio.

However, all NEFF bevel gearboxes can be supplied in a low-backlash version.

The circumferential backlash at the slow-running shaft is measured with the drive shaft blocked on a lever arm of 100 mm with a measuring force of 3% of the nominal torque and given as the torsion angle.

The following values are adjustable with normal gear wheel sets:

Version S1:  $i = 1:1$  to  $2:1 < 6$  angular minutes

Version S2:  $i = 3:1$  to  $6:1 < 10$  angular minutes

Tighter values require select, HPGS-toothed or polished gear wheel sets - please enquire.

## Preferable direction of rotation

In principle NEFF bevel gearboxes can be driven in both directions of rotation. Together with the direction of rotation, the spiral direction of a gear wheel set determines the internal load ratios of the gearbox.

If one selects the direction of rotation of the small gear contrary to its spiral direction (viewed from the shaft end face to the centre of the gearbox), then the axial force acts outwards. As a result the gear wheel set is pressed apart and causes a lowering of the noise level by 1 - 2 dBA.

NEFF manufactures the pinion as a left-hand spiral; the preferable direction of rotation is thus clockwise.

## Lubrication

NEFF bevel gearboxes are delivered with an oil filling and are maintenance-free under normal operating conditions. In case of extreme requirements or increased service life requirements, we recommend an oil change approx. every 15.000 hours of operation.

NEFF strives to select the best lubricant for each application and in this way to optimise the service life of the gearboxes.

Decisive for the choice of lubricants are the peripheral speed of the bevel gears, the power to be transmitted and the operating conditions.

An approximate guiding value for the type of lubrication used can be taken from the two selection diagrams and the lubricant table.

The correct type of lubrication can be selected on the basis of two selection diagrams and a lubricant table. The selection diagrams take into account the catalogue nominal torque and the mode of operation of the gearbox with 100% duty cycle or 30% / hr intermittent operation.

After the selection of the mode of operation and taking into consideration the operating conditions, the type of lubricant is defined with the speed of the slow-running transmission shaft. The type of lubrication, the necessity of gearbox ventilation and the gearbox oil can be taken from the lubricant table shown below.

The actual type of lubrication is defined by us for the specific application and may deviate from the table values!

There is a choice of modern synthetic high-performance lubricants. Proven lubricants with NSF-H1 approval (USDA-H1) can be selected for the use of gearboxes in the pharmaceutical or food industries.

NEFF gearboxes are provided with lifetime lubrication. Lubricant quantities are defined internally within the company for the installation position. Of course, biologically degradable oils or lubricants for extreme operating conditions can also be supplied. Please consult NEFF.

Due to the small convection surface the temperature of the gearbox can exceed 50 °C even under normal operating conditions.

If the gearbox exceeds this temperature in use, the ventilation filter provided must be installed in order to avoid overpressure in the gearbox and thus a leak in the gearbox.

The supply of fresh air must be ensured. Please consult us in cases of extreme environmental conditions (dust, moisture, etc.).

The ventilation bore can be dispensed with in case of intermittent operation or other operating conditions where the gearbox temperature is not expected to exceed 50 °C.

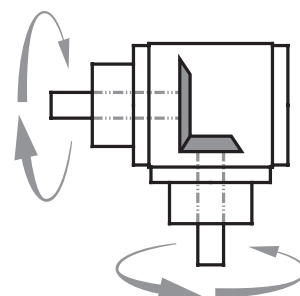

# Bevel gearboxes Lubrication

**Transmission ratios  $i=1:1-6:1$**   
**Ambient temperature  $-10^{\circ}\text{C}-+30^{\circ}\text{C}$**

## Duty cycle 100%/hr

Select n2 taking into account the maximum permissible values from the performance tables!

n2 [rpm]	Gearbox size		
	065	090	120
200	A	A	A
300	A	A	A
400	A	A	A
500	A	A	A
600	A	A	A
700	A	A	B 0
800	A	B 0	B 0
900	A	B 0	B 0
1000	A	B 0	B 0
1100	A	B 0	B 0
1200	B 0	B 0	B 1
1500	B 0	B 0	B 1
1600	B 0	B 1	B 1
1700	B 0	B 1	B 1
1800	B 0	B 1	B 1
2200	B 0	B 1	B 1
3000	B 1	B 1	B 2
3400	B 1	B 2	B 2

## Duty cycle 30%/hr

Select n2 taking into account the maximum permissible values from the performance tables!

n2 [rpm]	Gearbox size		
	065	090	120
400	A	A	A
500	A	A	A
700	A	A	A
800	A	A	A
900	A	A	A
1000	A	A	B 0
1100	A	A	B 0
1200	A	A	B 0
1300	A	A	B 0
1400	A	B 0	B 0
1500	A	B 0	B 0
1700	A	B 0	B 0
1900	A	B 0	B 1
2000	B 0	B 0	B 1
2200	B 0	B 0	B 1
2300	B 0	B 1	B 1
2800	B 0	B 1	B 1
3000	B 0	B 1	B 2
3300	B 0	B 1	B 2

	Code	Lubrication	Ventilation	Viscosity
Standard	A	Splash lubrication	Without	460
	B 0	Splash lubrication	Without	220
	B 1	Splash lubrication	with	220
	B 2	Splash lubrication	with	68

## Position of the ventilation filter

With the lubrication types B1 and B2 the gearbox is supplied with a ventilation filter. Please refer to the table below for the possible positions of the filter. The side of the gearbox on which the filter will be mounted is to be specified in the ordering designation.

e.g.: E4 = ventilation on side 4. If nothing is specified in the order, the position of the ventilation filter is determined by NEFF.

## Installation position - type V design, model A0-D0

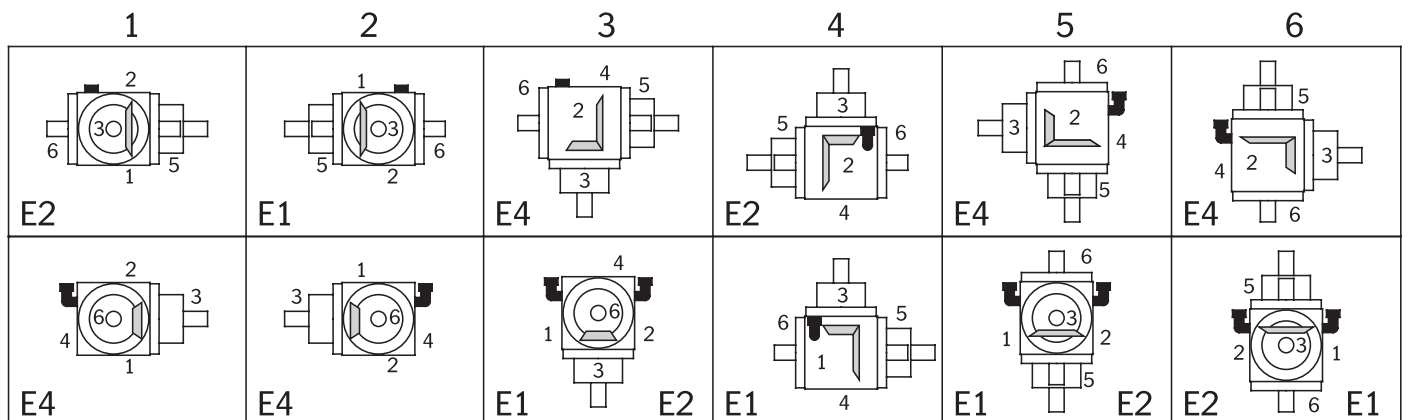



# Bevel gearbox Typ V 065

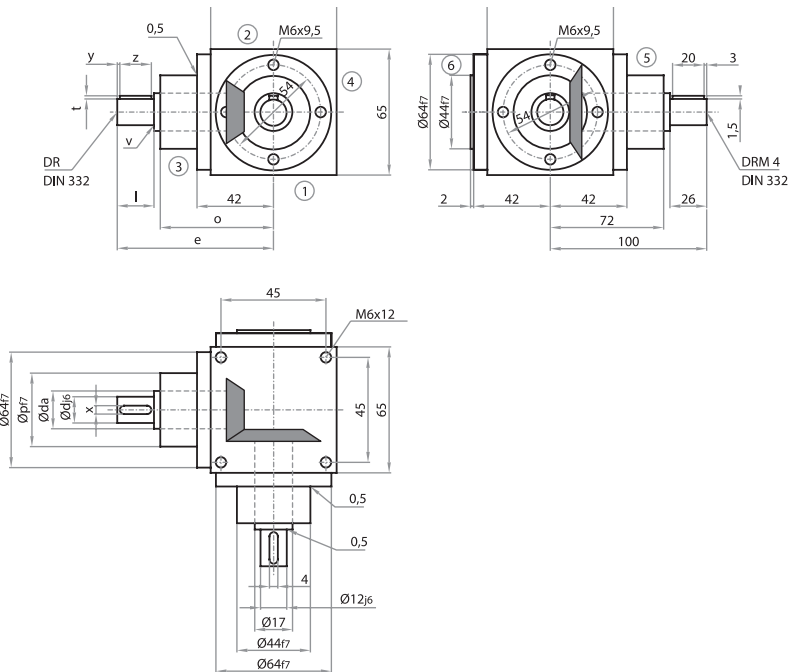

Caution: Caution: standard mounting threads in the housing only on sides 1, 2 & 4.  
Alternatively also possible on sides 3, 5 & 6 in the gird size 54 x 54.

## Design

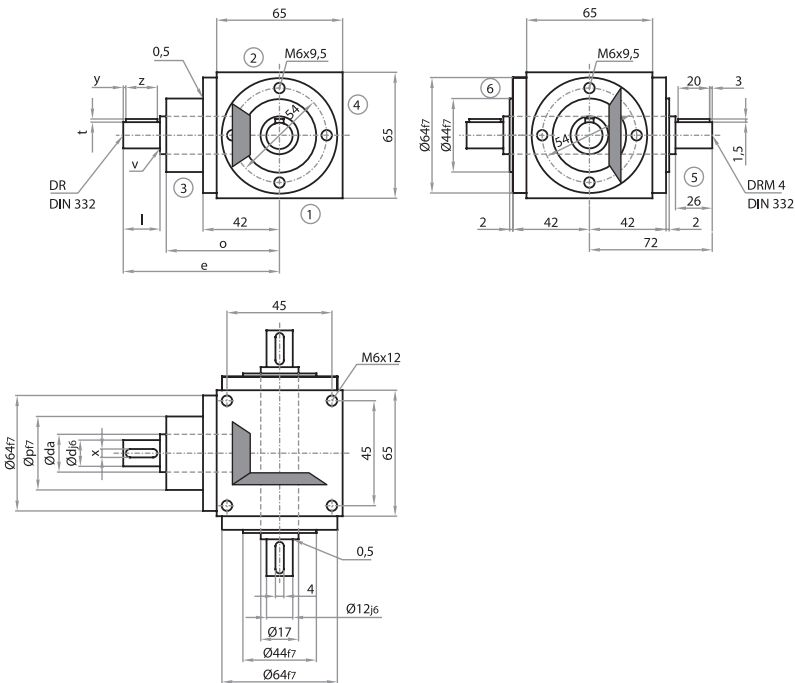
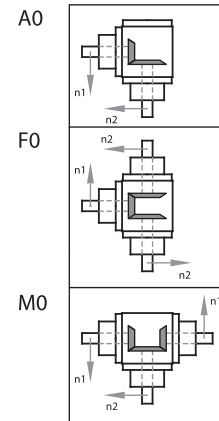

Caution: Caution: standard mounting threads in the housing only on sides 1, 2 & 4.  
Alternatively also possible on sides 3, 5 & 6 in the gird size 54 x 54.

## Design

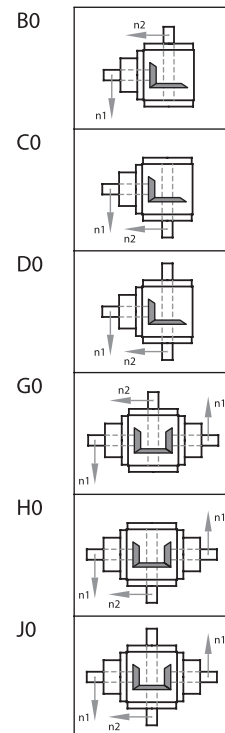

## Transmission ratio

Transmission ratio	d	da	l	v	x	y	z	t	DR	e	o	p
i = 1:1 - 2:1	12	17	26	0,5	4	3	20	1,5	M4	100	72	44

Transmission ratio	d	da	l	v	x	y	z	t	DR	e	o	p
i = 3:1	12	17	26	0,5	4	3	20	1,5	M4	100	72	44

# Bevel gearbox Type V 065

## Performances, torques

[n = min-1, P = kW, T = Nm]

i = n1	1:1 n2	P1N T2N	1,5:1 n2	P1N T2N	2:1 n2	P1N T2N	3:1 n2	P1N T2N
3000	3000	3.31 10.00	2000	2.20 10.00	1500	1.65 10.00	1000	1.10 10.00
2400	2400	2.65 10.00	1600	1.76 10.00	1200	1.32 10.00	800	0.88 10.00
1500	1500	1.82 11.00	1000	1.21 11.00	750	0.91 11.00	500	0.61 11.00
1000	1000	1.32 12.00	667	0.88 12.00	500	0.66 12.00	333	0.44 12.00
750	750	1.07 13.00	500	0.72 13.00	375	0.54 13.00	250	0.33 12.00
500	500	0.83 15.00	333	0.55 15.00	250	0.41 15.00	167	0.24 13.00
250	250	0.47 17.00	167	0.31 17.00	125	0.23 17.00	83	0.12 13.00
50	50	0.10 18.00	33	0.07 18.00	25	0.05 18.00	17	0.03 14.00
P1Nt T2max		1.60 25.00		1.60 25.00		1.60 25.00		1.60 23.00

## Radial forces (N)

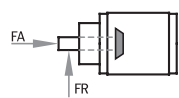

T2 Nm	n1 (1/min)					
	3000	1000	500	250	100	50
< 12	180	250	300	350	450	550
> 12	150	210	250	290	380	460

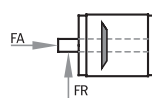

n2 (1/min)					
3000	1000	500	250	100	50
300	400	500	650	750	900
250	330	420	540	630	750

For further explanations and reinforced bearings, see General  
Axial forces FA = 50% of the radial forces - see General

## Mass moment of inertia J (kgcm<sup>2</sup>)

reduced to the drive shaft (n1)

Size	Dimension			
	1:1	1,5:1	2:1	3:1
A0	0.3888	0.2406	0.1839	0.1036
F0	0.5832	0.3270	0.2325	0.1252
M0	0.5832	0.3948	0.3192	0.1856
B0. C0	0.4231	0.3111	0.2330	0.1001
D0	0.4330	0.3155	0.2355	0.1012
GO. HO	0.6175	0.4653	0.3683	0.1821
J0	0.6274	0.4697	0.3708	0.1832

## Gearbox weight (kg)

Size	approx. weight
A0	2.3
F0	2.7
M0	2.7
B0. C0	2.2
D0	2.3
GO. HO	2.6
J0	2.7

# Bevel gearbox Type V 090

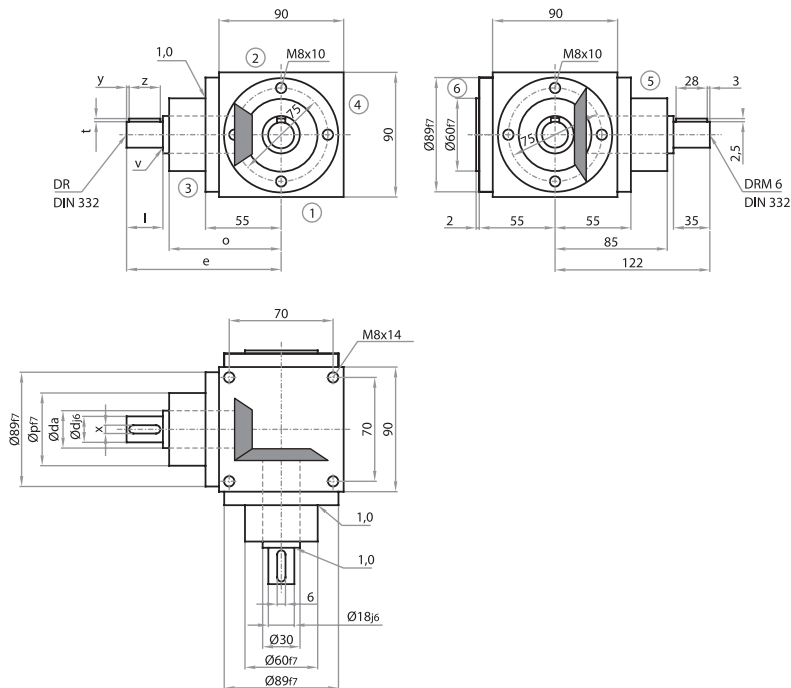

## Design

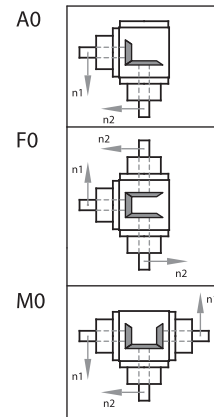

Caution: standard mounting threads in the housing only on sides 1, 2 & 4  
Alternatively also possible on sides 3, 5 & 6 in the gird size 75 x 75.

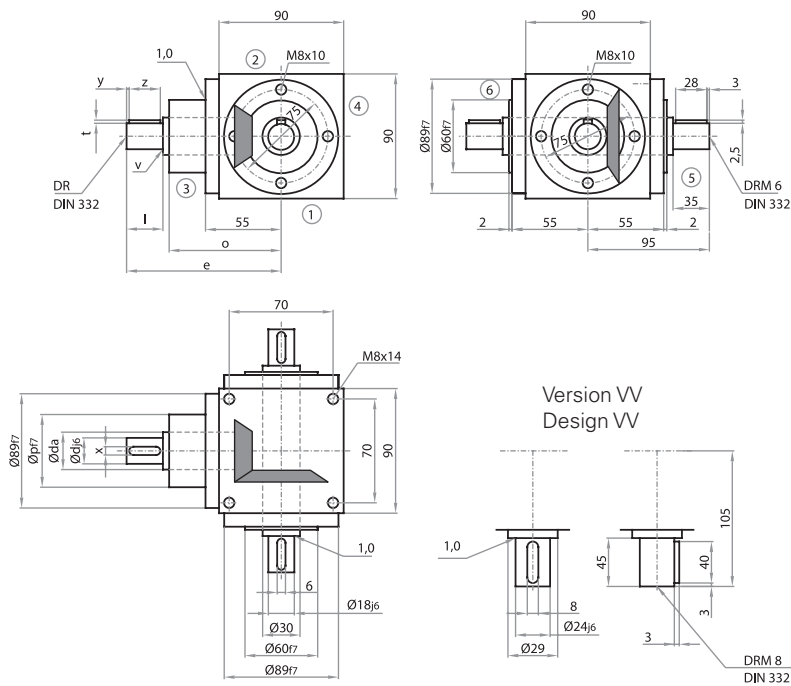

## Design

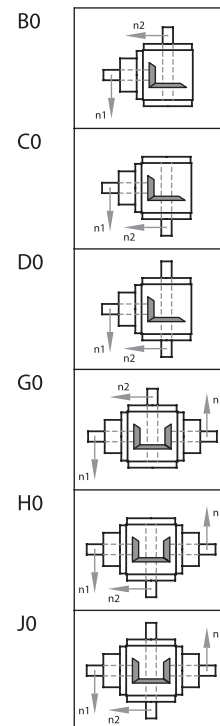

Achtung: Caution: standard mounting threads in the housing only on sides 1, 2 & 4  
Alternatively also possible on sides 3, 5 & 6 in the gird size 54 x 54.

### Transmission ratio

Transmission ratio	d	da	l	v	x	y	z	t	DR	e	o	p
i = 1:1 - 2:1	18	25	35	1	6	3	28	2.5	M6	122	85	60

Transmission ratio	d	da	l	v	x	y	z	t	DR	e	o	p
i = 3:1	12	20	35	0.5	4	3	28	1.5	M4	122	85	60

Transmission ratio	d	da	l	v	x	y	z	t	DR	e	o	p
i = 4:1	12	20	35	0.5	4	3	28	1.5	M4	132	95	60

Transmission ratio	d	da	l	v	x	y	z	t	DR	e	o	p
i = 5:1 - 6:1	12	20	35	0.5	4	3	28	1.5	M4	132	95	60

# Bevel gearbox Type V 090

## Performances, torques

[n = min-1, P = kW, T = Nm]

i = n1	1:1 n2	P1N T2N	1,5:1 n2	P1N T2N	2:1 n2	P1N T2N	3:1 n2	P1N T2N	4:1 n2	P1N T2N	5:1 n2	P1N T2N	6:1 n2	P1N T2N
3000	3000	8.93 27.00	2000	5.51 25.00	1500	3.80 23.00	1000	2.54 23.00	750	1.90 23.00	600	1.52 23.00	500	1.25 23.00
2400	2400	7.41 28.00	1600	4.59 26.00	1200	3.17 24.00	800	2.12 24.00	600	1.65 25.00	480	1.32 25.00	400	1.09 25.00
1500	1500	5.29 32.00	1000	3.20 29.00	750	2.23 27.00	500	1.49 27.00	375	1.12 27.00	300	0.89 27.00	250	0.74 27.00
1000	1000	3.75 34.00	667	2.35 32.00	500	1.71 31.00	333	1.14 31.00	250	0.85 31.00	200	0.68 31.00	167	0.53 29.00
750	750	3.06 37.00	500	1.93 35.00	375	1.32 32.00	250	0.88 32.00	187.5	0.66 32.00	150	0.53 32.00	125	0.40 29.00
500	500	2.20 40.00	333	1.36 37.00	250	0.94 34.00	167	0.63 34.00	125	0.47 34.00	100	0.37 34.00	83	0.27 29.00
250	250	1.21 44.00	167	0.74 40.00	125	0.50 36.00	83	0.33 36.00	62.5	0.25 36.00	50	0.20 36.00	42	0.14 30.00
50	50	0.28 50.00	33	0.16 45.00	25	0.10 37.00	17	0.07 37.00	12.5	0.05 37.00	10	0.04 37.00	8.3	0.03 33.00
P1Nt		3.80		3.80		3.80		3.80		3.80		3.80		3.80
T2max		105.00		45.00		80.00		70.00		70.00		60.00		50.00

## Radial forces (N)

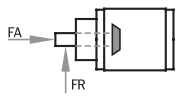

T2 Nm	n1 (1/min)					
	3000	1000	500	250	100	50
< 30	300	400	470	580	700	800
> 30	250	330	390	490	590	670

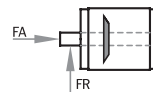

n2 (1/min)					
3000	1000	500	250	100	50
500	660	800	950	1250	1500
420	550	670	790	1040	1250

For further explanations and reinforced bearings, see General  
Axial forces FA = 50% of the radial forces - see General

## Mass moment of inertia J (kgcm<sup>2</sup>)

reduced to the drive shaft (n1)

Size	Dimension						
	1:1	1,5:1	2:1	3:1	4:1	5:1	6:1
A0	2.5590	1.4822	1.1437	0.8884	0.3631	0.3248	0.3062
F0	3.8385	2.0508	1.4636	1.0305	0.4430	0.3760	0.3418
M0	3.8385	2.3957	1.9675	1.6346	0.6462	0.5984	0.5769
B0. C0	3.3543	2.1833	1.3652	1.0465	0.4607	0.3933	0.3502
D0	3.3827	2.1959	1.3723	1.0496	0.4625	0.3945	0.3510
G0. H0	4.6338	3.0968	2.1890	1.7927	0.7438	0.6669	0.6209
J0	4.6622	3.1094	2.1961	1.7958	0.7456	0.6681	0.6217

## Gearbox weight (kg)

Size	approx. weight
A0	5.1
F0	6.3
M0	6.3
B0. C0	5.4
D0	5.5
G0. H0	6.9
J0	7

# Bevel gearbox Type V 120

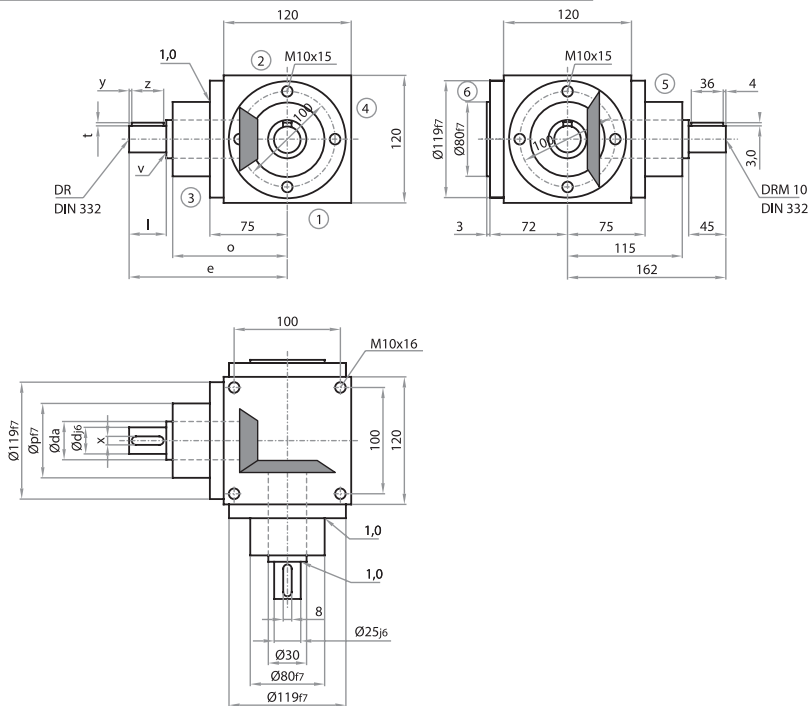

## Design

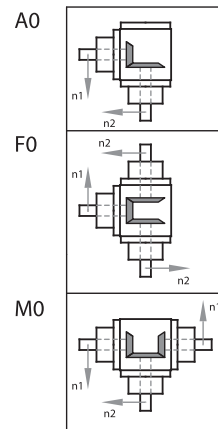

Caution: Standard mounting threads in the housing only on sides 1, 2 & 4.  
Alternatively also possible on sides 3, 5 & 6.

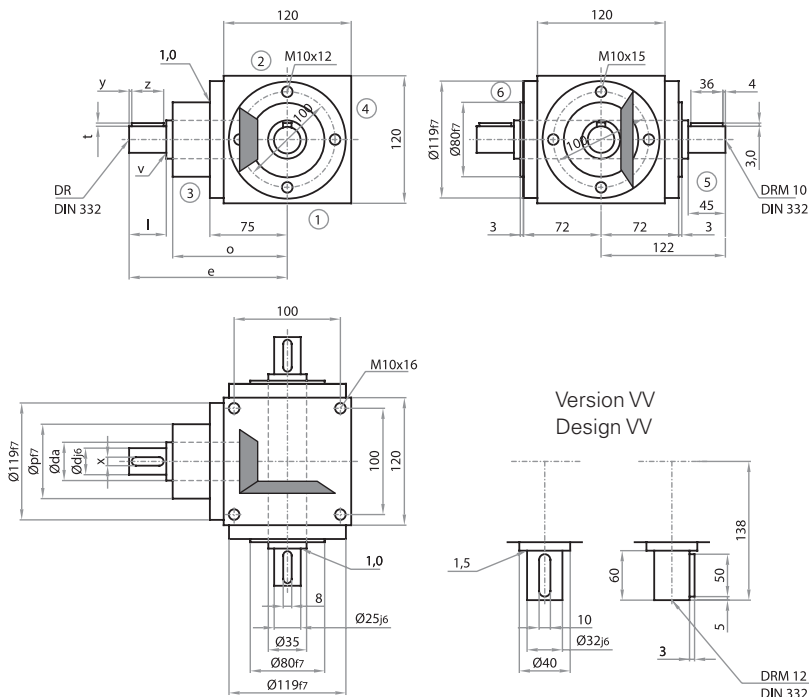

## Version VV Design VV

## Design

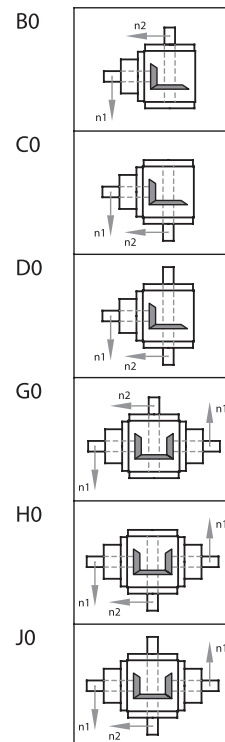

Caution: Standard mounting threads in the housing only on sides 1, 2 & 4.  
Alternatively also possible on sides 3, 5 & 6.

## Transmission ratio

Transmission ratio	d	da	l	v	x	y	z	t	DR	e	o	p
i = 1:1 - 2:1	25	30	45	1	8	4	36	3	M10	162	115	80

Transmission ratio	d	da	l	v	x	y	z	t	DR	e	o	p
i = 4:1	20	25	45	1	6	4	36	2.5	M6	172	125	80

Transmission ratio	d	da	l	v	x	y	z	t	DR	e	o	p
i = 3:1	20	25	45	1	6	4	36	2.5	M6	162	115	80

Transmission ratio	d	da	l	v	x	y	z	t	DR	e	o	p
i = 5:1 - 6:1	15	20	35	0.5	5	4	28	2	M5	162	125	70



# Bevel gearbox Type V 120

## Performances, torques

[n = min-1, P = kW, T = Nm]

i = n1	1:1 n2	P1N T2N	1,5:1 n2	P1N T2N	2:1 n2	P1N T2N	3:1 n2	P1N T2N	4:1 n2	P1N T2N	5:1 n2	P1N T2N	6:1 n2	P1N T2N
3000	3000	21.82 66.00	2000	13.45 61.00	1500	9.26 56.00	1000	6.39 58.00	750	4.96 60.00	600	3.97 60.00	500	2.95 54.00
2400	2400	18.52 70.00	1600	11.46 65.00	1200	8.07 61.00	800	5.56 63.00	600	4.43 67.00	480	3.44 65.00	400	2.53 57.00
1500	1500	13.56 82.00	1000	8.60 78.00	750	6.03 73.00	500	4.08 74.00	375	3.06 74.00	300	2.38 72.00	250	1.75 64.00
1000	1000	10.14 92.00	667	6.32 86.00	500	4.46 81.00	333	3.01 82.00	250	2.18 79.00	200	1.76 80.00	167	1.22 66.00
750	750	8.51 103.00	500	5.18 94.00	375	3.55 86.00	250	2.40 87.00	187.5	1.69 82.00	150	1.42 86.00	125	0.94 68.00
500	500	6.34 115.00	333	3.85 100.00	250	2.54 92.00	167	1.66 90.00	125	1.16 84.00	100	0.98 89.00	83	0.63 69.00
250	250	3.39 123.00	167	1.99 100.00	125	1.35 98.00	83	0.87 95.00	62.5	0.60 87.00	50	0.51 92.00	42	0.33 71.00
50	50	0.72 130.00	33	0.41 100.00	25	0.29 107.00	17	0.21 110.00	12.5	0.12 90.00	10	0.10 95.00	8.3	0.06 66.00
P1Nt		6.20		6.20		6.20		6.20		6.20		6.20		6.20
T2max		220.00												

## Radial forces (N)

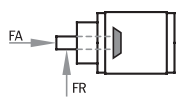

T2 Nm	n1 (1/min)			
	3000	1000	500	250
< 12	180	250	300	350
> 12	150	210	250	290

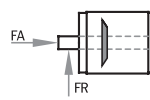

n2 (1/min)			
3000	1000	500	250
300	400	500	650
250	330	420	540

For further explanations and reinforced bearings, see General  
Axial forces FA = 50% of the radial forces - see General

## Mass moment of inertia J (kgcm<sup>2</sup>)

reduced to the drive shaft (n1)

Size	Dimension			
	1:1	1,5:1	2:1	3:1
A0	0.3888	0.2406	0.1839	0.1036
F0	0.5832	0.3270	0.2325	0.1252
M0	0.5832	0.3948	0.3192	0.1856
B0, C0	0.4231	0.3111	0.2330	0.1001
D0	0.4330	0.3155	0.2355	0.1012
G0, H0	0.6175	0.4653	0.3683	0.1821
J0	0.6274	0.4697	0.3708	0.1832

## Gearbox weight (kg)

Size	approx. weight
A0	2.3
F0	2.7
M0	2.7
B0, C0	2.2
D0	2.3
G0, H0	2.6
J0	2.7

## Mounting side

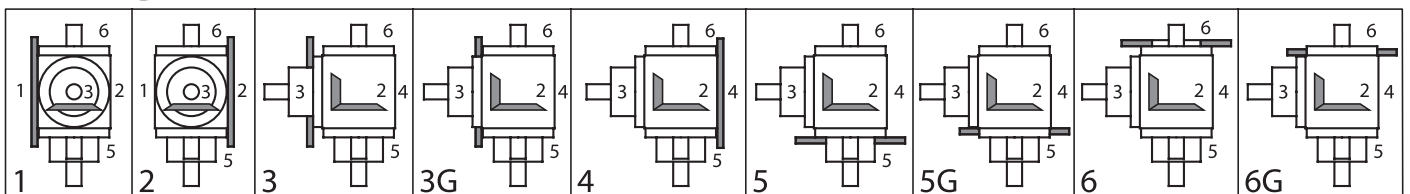

## Installation positions (gearbox side underneath)

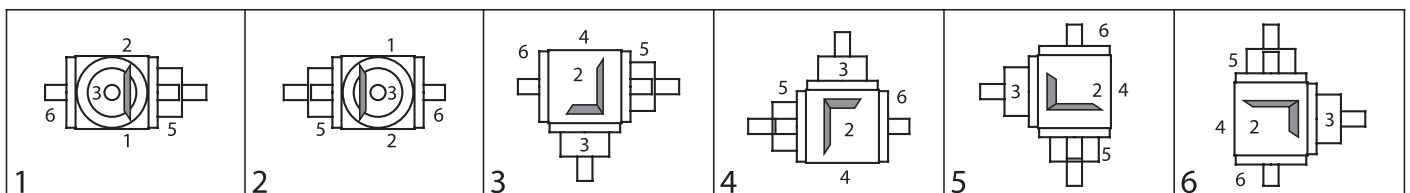

# Ordering code

Bevel gearbox

## Ordering code Bevel gearbox

<b>1</b>		<b>2</b>		<b>3</b>	<b>4</b>		<b>5</b>		<b>6</b>		<b>7</b>					

No.	Designation	Code	Description
<b>1</b>	Size	<b>NV 65</b>	
		<b>NV 90</b>	
		<b>NV 120</b>	
<b>2</b>	Design	<b>A0, F0</b>	see pages 108/110/112
		<b>M0, B0</b>	
		<b>C0, D0</b>	
		<b>G0, H0, J0</b>	
<b>3</b>	Transmission ratio	<b>1:1</b>	Gearboxes available for all sizes
		<b>1,5:1</b>	
		<b>2:1</b>	
		<b>3:1</b>	
<b>4</b>	Mounting side	<b>1, 2, 3</b>	see page 113
		<b>3G, 4, 5,</b>	
		<b>5G, 6, 6G</b>	
<b>5</b>	Installation position	<b>1, 2, 3, 4,</b>	see pages 106/113
		<b>5, 6</b>	
<b>6</b>	Speed in [rpm]		Specify maximum output speed
<b>7</b>	Special requirements	<b>0</b>	None
		<b>1</b>	According to specification, description or drawing

# Installation and maintenance

## Installation of worm gear screw jack systems

### Direction of rotation

Before starting installation work, the direction of rotation of all worm gear screw jacks, bevel gear boxes and the drive motor must be checked with regard to the feed direction of each individual worm gear screw jack.

### Alignment errors

All components must be carefully aligned during installation. Alignment errors and stresses increase power consumption and lead to overheating and premature wear. Before a drive unit is attached, each worm gear screw jack should be turned through its entire length by hand without load. Variations in the amount of force required and/or axial marks on the outside diameter of the spindle indicate alignment errors between the worm gear screw jack and its additional guides. In this case, the relevant mounting bolts must be loosened and the worm gear screw jack turned through by hand again. If the amount of force required is now constant throughout, the appropriate components must be aligned. If not, the alignment error must be localized by loosening additional mounting bolts.

### Test run

The direction of rotation of the complete system and correct operation of the limit switches must be checked again before attaching the drive motor. In the case of version N (translating screw jack), check that the spindle is lubricated with grease from the interior of the gear box and relubricate if necessary. In the case of version R (rotating screw jack), the screw jack should be coated with suitable grease to provide lubrication for lifting operation. The first test runs can then be carried out without load. A maximum operating time of 30 % cannot be exceeded at trial runs under weight for worm gear screw jacks with trapezoidal spindles.

### Operation

The loads, speeds of rotation and operating conditions specified for the worm gear screw jacks and transmission components must not be exceeded, even briefly. Failure to observe this condition will invalidate all claims under guarantee.

## Guiding values for the mounting of bearing covers

Type	Tightening Torque [Nm]
M 0	3
M 1	5
M 2	9
M 3	13
M 4	32
M 5	60
J 1	70
J 2	150
J 3	150
J 4	220
J 5	300

## Maintenance of worm gear screw jacks

### Safety

All mounting bolts must be retightened after a short period of operation. Under extreme operating conditions, the wear on the screw nut (worm gear) must be checked at shorter intervals, depending on the duty cycle, by inspecting the backlash in the thread. The screw nut (worm gear) must be replaced if the axial backlash with a single-start thread is more than one-quarter of the thread pitch.

### Lubrication

The worm gear screw jacks are lubricated by the manufacturer and are ready for operation on delivery. The versions N/V must be lubricated via their grease nipples with one of the greases specified below at intervals of 50 – 100 operating hours, depending on the grease seepage and in cases of high duty cycles. The spindle should be cleaned and greased at the same time. We recommend that the gearbox be cleaned to remove old grease and refilled with fresh grease after approx. 1500 operating hours or 36 months.

The worm gear screw jacks can be dismantled relatively easily:

- Unscrew the two threaded pins securing the bearing cover.
- Unscrew the spindle and remove the spindle protection if necessary.
- Unscrew the bearing cover with the aid of a face spanner.

Proceed as follows to refit the bearing cover: fit the bearing cover firmly (using approx. ten times the force shown in the table of "Guiding values for fitting the bearing cover").

Then release it and refit it with the guiding value from the table, at the same time checking the axial backlash and smooth running.

Standard grease:

Neff Grease 2

Optional greases:

Castrol Spheerol BM2  
Mobil Mobilgrease XHP  
Shell Retinax HD2  
Klüber Microlube GBO

## Lubrication per screw jack

Type	Filling quantity [kg]
M 0	0.03
M 1	0.06
M 2	0.14
M 3	0.24
M 4	0.8
M 5	1.1
J 1	1.5
J 2	2.0
J 3	2.0
J 4	2.7
J 5	3.2



## Notes

## Contact person Sales

### 📍 Heilbronn



#### Sales Manager

Stephan Hankel  
Phone: +49 (0) 7131/27177-77  
Fax: +49 (0) 7131/27177-66  
email: s.hankel@neff-gt.de

### 📍 Weil im Schönbuch

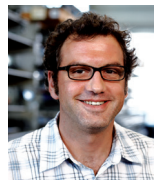

#### Sales Screw drives

Dieter Sautter  
Phone: +49 (0) 7157/53890-13  
Fax: +49 (0) 7157/53890-25  
email: d.sautter@neff-gt.de

### 📍 Weil im Schönbuch



#### Sales Screw jacks

Sandro Garofano  
Phone: +49 (0) 7157/53890-16  
Fax: +49 (0) 7157/53890-25  
email: s.garofano@neff-gt.de

### 📍 Heilbronn



#### Sales Screw drives, Screw jacks

Stefanie Eckhard  
Phone: +49 (0) 7131/27177-70  
Fax: +49 (0) 7131/27177-66  
email: s.eckhard@neff-gt.de

## Contact person Design

### 📍 Weil im Schönbuch



#### Design Screw drives

Andreas Ries  
Phone: +49 (0) 7157/53890-19  
Fax: +49 (0) 7157/53890-25  
email: a.ries@neff-gt.de

### 📍 Weil im Schönbuch



#### Design Screw jacks

Stephan Steck  
Phone: +49 (0) 7157/53890-19  
Fax: +49 (0) 7157/53890-25  
email: s.steck@neff-gt.de

### 📍 Heilbronn



#### Design Screw jacks

Serkan Sinirci  
Phone: +49 (0) 7131/27177-75  
Fax: +49 (0) 7131/27177-66  
email: s.sinirci@neff-gt.de



## Contact

NEFF Gewindetriebe GmbH  
Karl-Benz-Str. 24  
71093 Weil im Schönbuch  
Postbox 1230  
71108 Waldenbuch  
Germany

Phone: +49 (0) 71 57/53890-0  
Fax: +49 (0) 71 57/53890-25  
[www.neff-gewindetriebe.de](http://www.neff-gewindetriebe.de)  
[info@neff-gewindetriebe.de](mailto:info@neff-gewindetriebe.de)