

# Collaborative Parallel Grippers

## ECG3-10080 3-Finger

ECG is a collaborative 3-finger parallel gripper that is equipped with symmetrically parallel fingers.

### Advantages

- Compact design
- Smooth body with rounded edges ideal for collaborative applications
- Grip control: force and position adjustment
- Quick open/close time with speed adjustment
- Grip feedback and part detection: gripper status can be read at the PLC/Controller and visualized on the unit via LED's
- Plug and play: mechanical and software interface for major cobot manufacturers
- Multiple communication modes: the gripper supports Modbus RTU protocol and IO mode control. Other protocols such as USB and ETHERNET can be implemented through a protocol converter.
- ROS compatible
- Designed for harsh environments
- Grip actuation via embedded controller.
- Brake locking mechanism.



## SPECIFICATIONS

Model	Stroke per Jaw	Gripping Force per Jaw	Total Gripping Force	Opening/Closing Time	Nominal Voltage	Nominal Current	Max Current	Repeatability (Positioning)	Recommended Workpiece Weight*	Weight
<b>ECG3-10080</b>	10 mm 0.39 in	20 - 80 N 4.50 - 17.98 lb	60 - 240 N 13.49 - 53.95 lb	0.2 / 0.2 s	24 V DC $\pm$ 10%	0.30 A	1.00 A	$\pm$ 0.03 mm $\pm$ 0.001 in	1.5 kg 3.31 lb	1.50 kg 3.31 lb

\* Recommended workpiece weight depends on the shape of the part, the material and friction of the contact surface and the acceleration of the motion.

Communication Interface **Standard: Modbus RTU (RS485), Digital I/O**  
**Optional: TCP/IP, USB2.0, CAN2.0A, PROFINET, EtherCAT**

IP Protection Class **IP 67**

Noise Emission (Sound Pressure)  $\leq$  **40 dB(A) in any direction**

Recommended operating environment **0-40 °C (32-104 °F), < 85% RH**

For this type of gripper the use of the standard fingers is recommended.

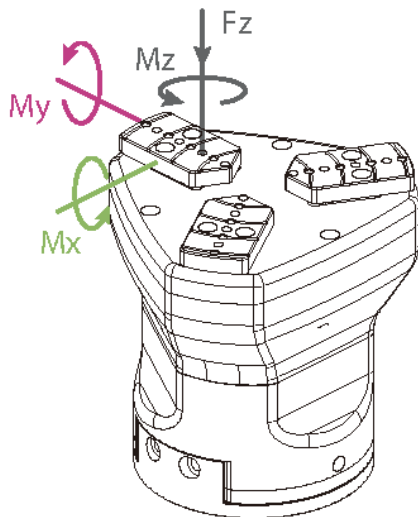

### Allowable vertical load (static)

Fz 200 N (44.96 lb)

### Allowable moment (static)

Mx 2.5 Nm (22.13 in-lb)

My 2 Nm (17.70 in-lb)

Mz 3 Nm (26.55 in-lb)



# PRODUCT INFORMATION

# ECG3-10080 3-Finger

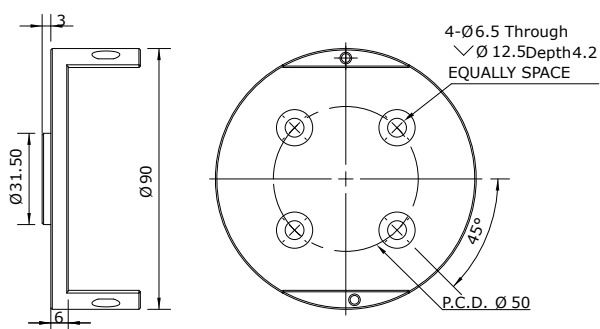
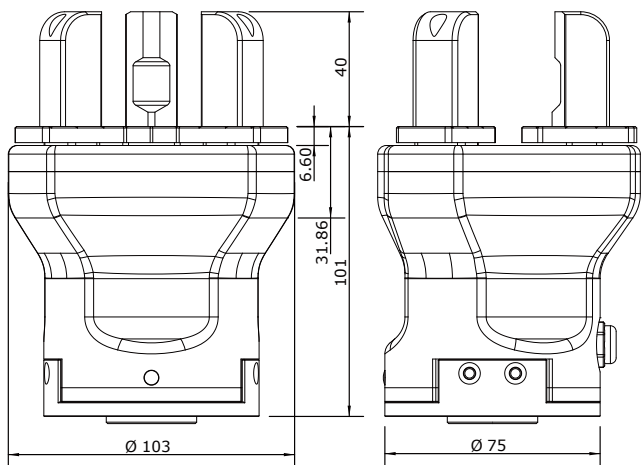

■ Conform to ISO 9409-1-50-4-M6 Standard flange

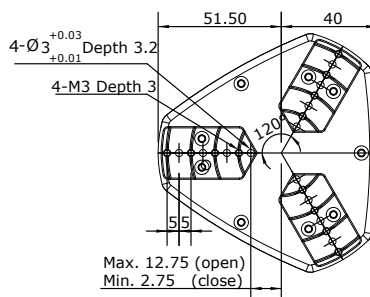

■ Custom fin ger mounting size



Applied Robotics  
A COMPANY OF EFFECTO<sup>®</sup>  
Applied Robotics  
648 Saratoga Road  
Glennville, NY 12302 USA  
Tel. +1 518 384 1000 Fax +1.5183841200  
info@appliedrobotics.com  
www.appliedrobotics.com



EFFECTO GROUP S.p.A.  
Via Roma, 141/143  
28017 San Maurizio d'Opaglio (NO) - Italy  
Tel. +39 0322 96142 Fax +39 0322 967453  
info@effecto.com  
www.effecto.com

