

Electric Parallel Grippers

EIG2-07008 2-Finger

EIG is an electric 2-finger parallel gripper that is equipped with two symmetrically parallel fingers.

Advantages

- Compact size
- Slim rectangular body with five installation positions for flexible mounting
- Grip control: force and position adjustment
- Quick open/close time with speed adjustment
- Grip feedback and part detection: gripper status can be read at the PLC/Controller and visualized on the unit via LED's
- Multiple communication modes: the gripper supports Modbus RTU protocol and IO mode control. Other protocols such as USB and ETHERNET can be implemented through a protocol converter.
- Grip actuation via embedded controller.



SPECIFICATIONS

Model	Stroke per Jaw	Gripping Force per Jaw	Total Gripping Force	Opening/Closing Time	Nominal Voltage	Nominal Current	Max Current	Repeatability (Positioning)	Recommended Workpiece Weight*	Weight
EIG2-07008	7 mm 0.28 in	2 - 8 N 0.45 - 1.80 lb	4 - 16 N 0.90 - 3.60 lb	0.2 / 0.2 s	24 V DC \pm 10%	0.40 A	0.70 A	\pm 0.02 mm \pm 0.001 in	0.10 kg 0.22 lb	0.40 kg 0.88 lb

* Recommended workpiece weight depends on the shape of the part, the material and friction of the contact surface and the acceleration of the motion.

Communication Interface **Standard: Modbus RTU (RS485), Digital I/O**
Optional: TCP/IP, USB2.0, CAN2.0A, PROFINET, EtherCAT

IP Protection Class **IP 40**

Noise Emission (Sound Pressure) \leq **40 dB(A) in any direction**

Recommended operating environment **0-40 °C (32-104 °F), < 85% RH**

For this type of gripper the use of the standard fingers is recommended.

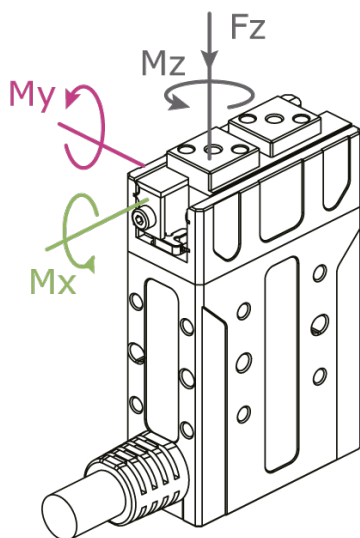

Allowable vertical load (static)

Fz 90 N (20.23 lb)

Allowable moment (static)

Mx 0.55 Nm (4.87 in-lb)

My 0.45 Nm (3.98 in-lb)

Mz 0.55 Nm (4.87 in-lb)



PRODUCT INFORMATION

EIG2-07008 2-Finger

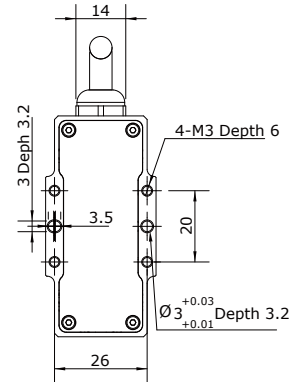
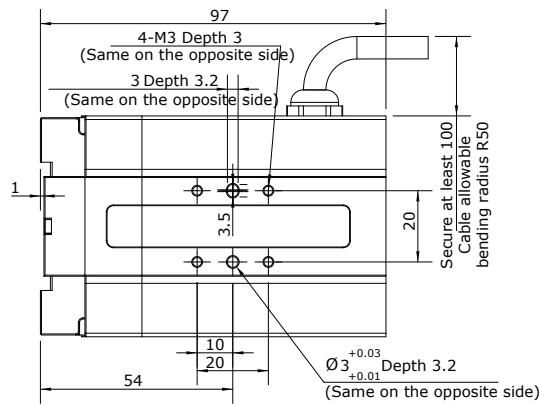
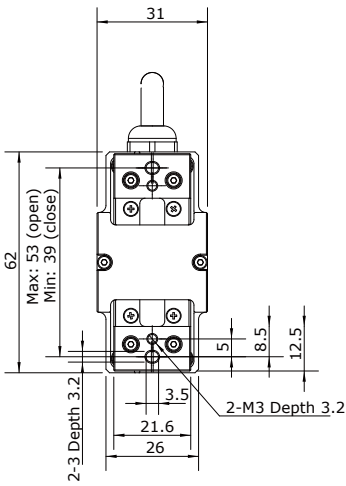
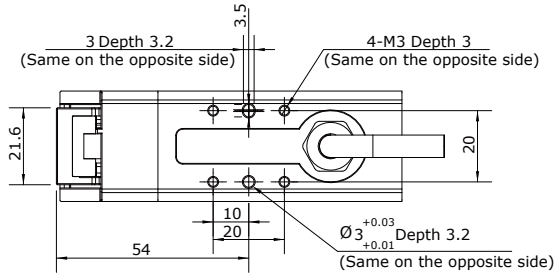

Applied Robotics
 A COMPANY OF EFFECTO
 Applied Robotics
 648 Saratoga Road
 Glensville, NY 12302 USA
 Tel. +1 518 384 1000 Fax +1.5183841200
 info@appliedrobotics.com
 www.appliedrobotics.com



EFFECTO GROUP S.p.A.
 Via Roma, 141/143
 28017 San Maurizio d'Opaglio (NO) - Italy
 Tel. +39 0322 96142 Fax +39 0322 967453
 info@effecto.com
 www.effecto.com

