

Electric Parallel Grippers

EIG2-13005 2-Finger

EIG is an electric 2-finger parallel gripper that is equipped with two symmetrically parallel fingers.

Advantages

- Compact size
- Slim rectangular body with five installation positions for flexible mounting
- Grip control: force and position adjustment
- Quick open/close time with speed adjustment
- Grip feedback and part detection: gripper status can be read at the PLC/Controller and visualized on the unit via LED's
- Multiple communication modes: the gripper supports Modbus RTU protocol and IO mode control. Other protocols such as USB and ETHERNET can be implemented through a protocol converter.
- Grip actuation via embedded controller.
- Brake locking mechanism on request.



SPECIFICATIONS

Model	Stroke per Jaw	Gripping Force per Jaw	Total Gripping Force	Opening/Closing Time	Nominal Voltage	Nominal Current	Max Current	Repeatability (Positioning)	Recommended Workpiece Weight*	Weight
EIG2-13005	13 mm 0.51 in	0.8 - 5 N 0.18 - 1.12 lb	1.6 - 10 N 0.36 - 2.24 lb	0.2 / 0.2 s	24 V DC \pm 10%	0.40 A	0.70 A	\pm 0.02 mm \pm 0.001 in	0.10 kg 0.22 lb	0.40 kg 0.88 lb

* Recommended workpiece weight depends on the shape of the part, the material and friction of the contact surface and the acceleration of the motion.

Communication Interface **Standard: Modbus RTU (RS485), Digital I/O**
Optional: TCP/IP, USB2.0, CAN2.0A, PROFINET, EtherCAT

IP Protection Class **IP 40**

Noise Emission (Sound Pressure) \leq **40 dB(A) in any direction**

Recommended operating environment **0-40 °C (32-104 °F), < 85% RH**

For this type of gripper the use of the standard fingers is recommended.

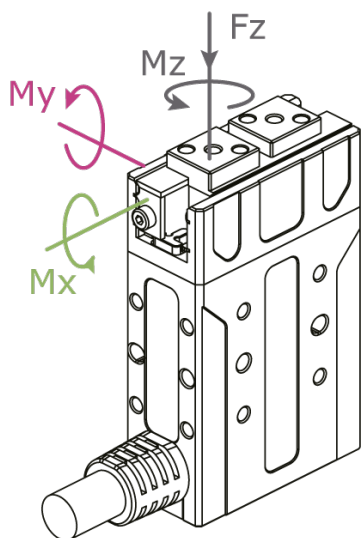

Allowable vertical load (static)

Fz 50 N (11.24 lb)

Allowable moment (static)

Mx 0.3 Nm (2.66 in-lb)

My 0.25 Nm (2.21 in-lb)

Mz 0.3 Nm (2.66 in-lb)



PRODUCT INFORMATION

EIG2-13005 2-Finger

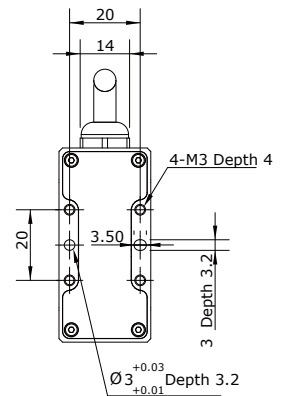
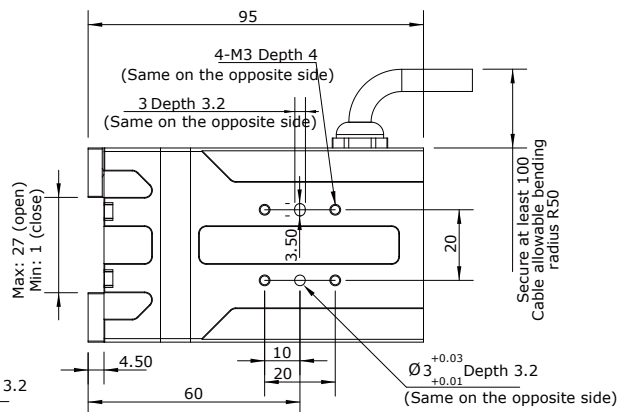
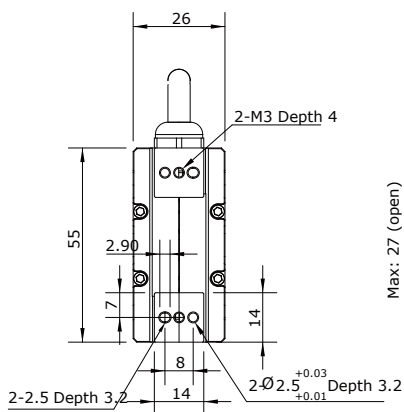
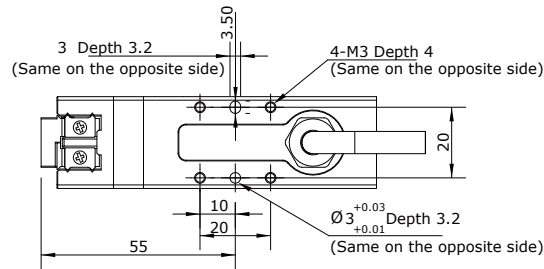

Applied Robotics
648 Saratoga Road

Glenville, NY 12302 USA
Tel. +1 518 384 1000 Fax +1.5183841200
info@appliedrobotics.com
www.appliedrobotics.com



EFFECTO GROUP S.p.A.
Via Roma, 141/143

28017 San Maurizio d'Opaglio (NO) - Italy
Tel. +39 0322 96142 Fax +39 0322 967453
info@effecto.com
www.effecto.com

