

# Electric Parallel Grippers

## EIG2-40140 2-Finger

EIG is an electric 2-finger parallel gripper that is equipped with two symmetrically parallel fingers.

### Advantages

- Compact size
- Slim rectangular body with five installation positions for flexible mounting
- Grip control: force and position adjustment
- Quick open/close time with speed adjustment
- Grip feedback and part detection: gripper status can be read at the PLC/Controller and visualized on the unit via LED's
- Multiple communication modes: the gripper supports Modbus RTU protocol and IO mode control. Other protocols such as USB and ETHERNET can be implemented through a protocol converter.
- Grip actuation via embedded controller.
- Brake locking mechanism.



## SPECIFICATIONS

Model	Stroke per Jaw	Gripping Force per Jaw	Total Gripping Force	Opening / Closing Time	Nominal Voltage	Nominal Current	Max Current	Repeatability (Positioning)	Recommended Workpiece Weight*	Weight (fingers excluded)
<b>EIG2-40140</b>	40 mm 1.57 in	40 - 140 N 8.99 - 31.47 lb	80 - 280 N 17.98 - 62.95 lb	0.7 / 0.7 s	24 V DC ± 10%	0.50 A	1.20 A	± 0.03 mm ± 0.001 in	3.00 kg 6.61 lb	1.00 kg 2.20 lb

\* Recommended workpiece weight depends on the shape of the part, the material and friction of the contact surface and the acceleration of the motion.

Communication Interface **Standard: Modbus RTU (RS485), Digital I/O**  
**Optional: TCP/IP, USB2.0, CAN2.0A, PROFINET, EtherCAT**

IP Protection Class **IP 54**  
Noise Emission (Sound Pressure) **≤ 40 dB(A) in any direction**  
Recommended operating environment **0-40 °C (32-104 °F), < 85% RH**

For this type of gripper the use of the standard fingers is recommended.

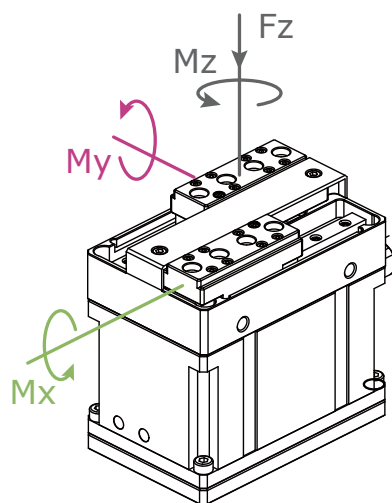

### Allowable vertical load (static)

Fz 300 N (67.44 lb)

### Allowable moment (static)

Mx 7 Nm (61.96 in-lb)

My 7 Nm (61.96 in-lb)

Mz 7 Nm (61.96 in-lb)



# PRODUCT INFORMATION

# EIG2-40140 2-Finger

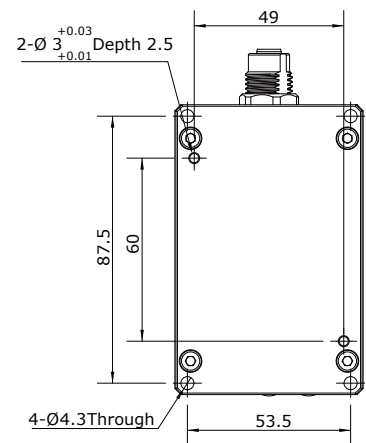
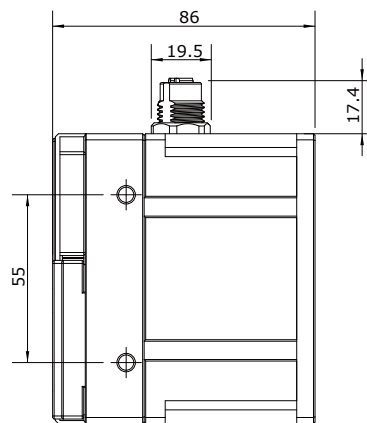
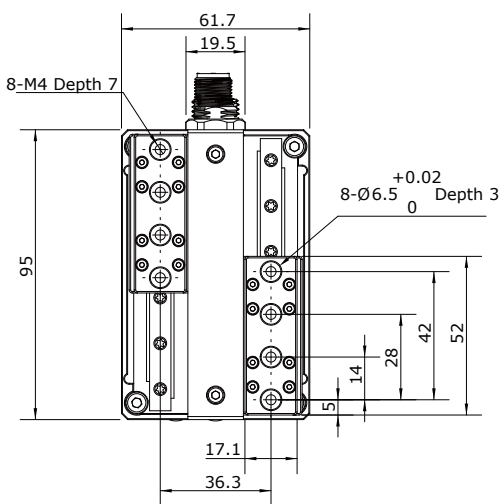
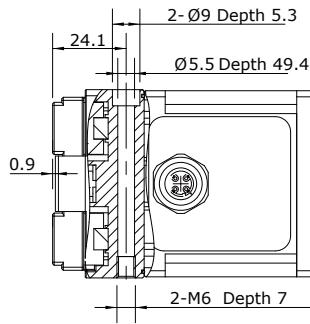

Applied Robotics  
 648 Saratoga Road  
 Glensville, NY 12302 USA  
 Tel. +1 518 384 1000 Fax +1.5183841200  
 info@appliedrobotics.com  
 www.appliedrobotics.com



EFFECTO GROUP S.p.A.  
 Via Roma, 141/143  
 28017 San Maurizio d'Opaglio (NO) - Italy  
 Tel. +39 0322 96142 Fax +39 0322 967453  
 info@effecto.com  
 www.effecto.com



01.2023\_Rev.02\_EU