

Electric Rotating Grippers

ERG2-18100 2-Finger

ERG is a rotating electric 2-finger parallel gripper that is equipped with two self-centering fingers.

Advantages

- Compact size
- Slim smooth body with four installation positions for flexible mounting
- Grip actuation via embedded controller
- Grip control: force and position adjustment
- Adjustable rotation angle and torque
- Infinite rotation
- Grip feedback and part detection: gripper status can be read at the PLC/Controller and visualized on the unit via LED's
- Multiple communication modes: the gripper supports Modbus RTU protocol and IO mode control. Other protocols such as USB and ETHERNET can be implemented through a protocol converter.



SPECIFICATIONS

Model	Stroke per Jaw	Gripping Force per Jaw	Total Gripping Force	Rotation Torque	Max Rotation Speed	Peak Torque	Nominal Current	Max Current	Repeatability (Swiveling)	Repeatability (Positioning)	Recommended Workpiece Weight*	Weight
ERG2-18100	17.5 mm 0.69 in	40 - 100 N 9.0 - 22.5 lb	80 - 200 N 18.0 - 45.0 lb	0.35 Nm 3.10 in-lb	1400 deg/s	1.5 Nm	2.0 A	5.0 A	± 0.05 deg	± 0.02 mm ± 0.079 in	1.00 kg 2.21 lb	0.65 kg 1.43 lb

* Recommended workpiece weight depends on the shape of the part, the material and friction of the contact surface and the acceleration of the motion.

Communication Interface **Standard: Modbus RTU (RS485), Digital I/O**

Optional: TCP/IP, USB2.0, CAN2.0A, PROFINET, EtherCAT (via converter device)

Nominal voltage **24 V DC ± 10%**

IP protection class **IP 40**

Noise Emission (Sound Pressure) **≤ 70 dB(A) in any direction**

Recommended operating environment **0-40 °C (32-104 °F), < 85% RH**

For this type of gripper the use of the standard fingers is recommended.

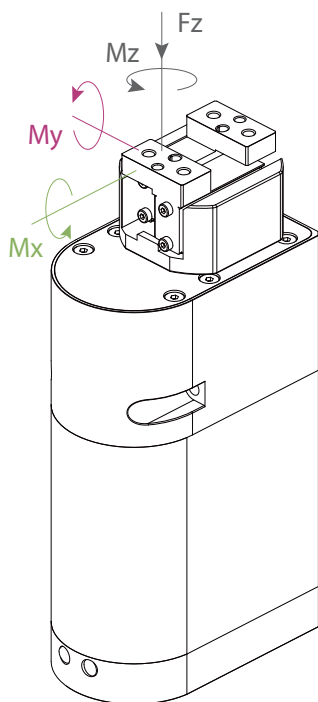

Allowable vertical load (static)

Fz 200 N (44.96 lb)

Allowable moment (static)

Mx 3.0 Nm (26.55 in-lb)

My 3.0 Nm (26.55 in-lb)

Mz 2.5 Nm (22.13 in-lb)



PRODUCT INFORMATION

ERG2-18100 2-Finger

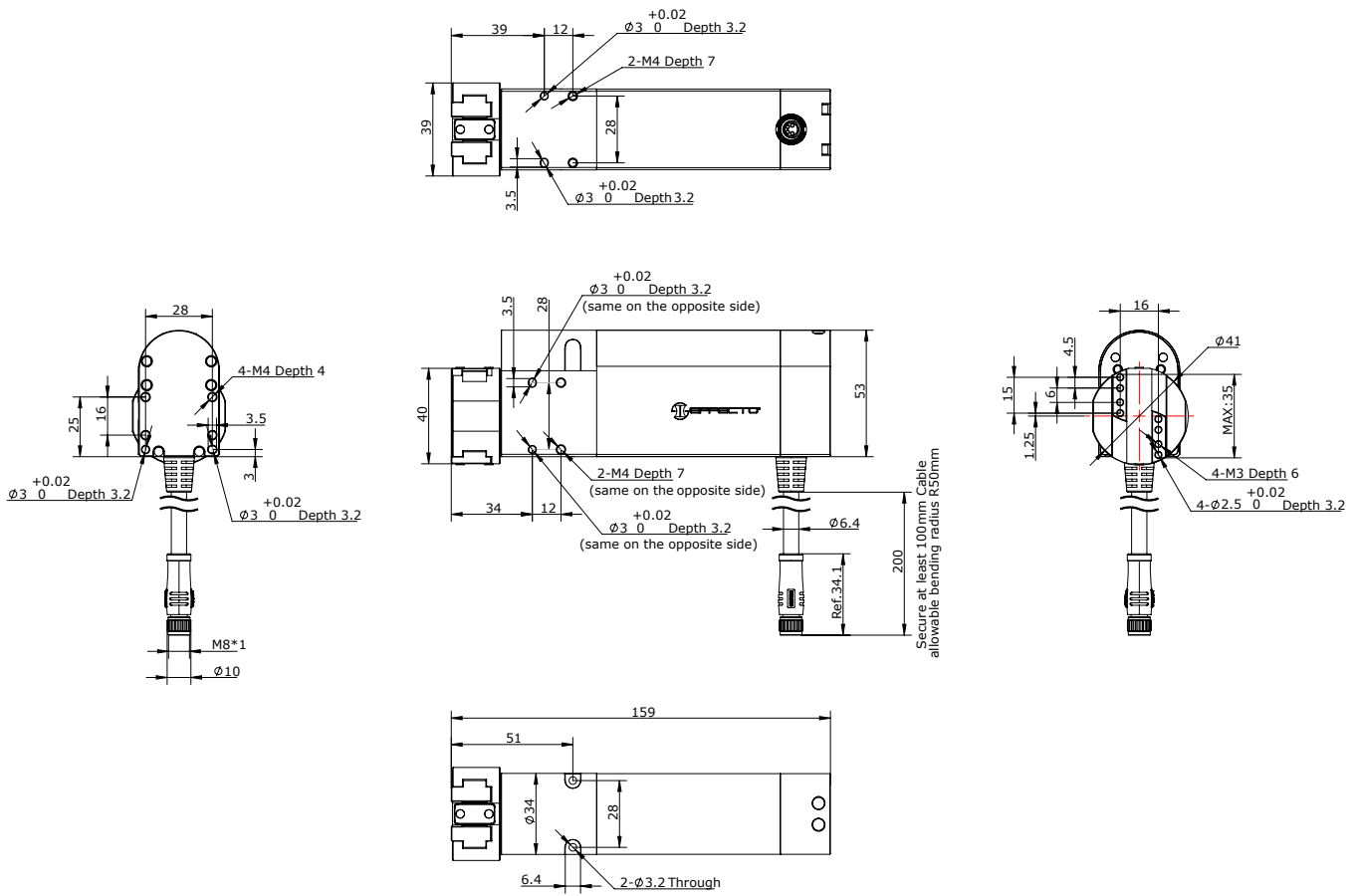

Applied Robotics
 A COMPANY OF EFFECTO[®]
 Applied Robotics
 648 Saratoga Road
 Glenville, NY 12302 USA
 Tel. +1 518 384 1000 Fax +1.5183841200
 info@appliedrobotics.com
 www.appliedrobotics.com



EFFECTO GROUP S.p.A.
 Via Roma, 141/143
 28017 San Maurizio d'Opaglio (NO) - Italy
 Tel. +39 0322 96142 Fax +39 0322 967453
 info@effecto.com
 www.effecto.com

