

# Pneumatic O-Ring Grippers PM 6-Finger

PM are innovative multi-finger grippers for handling and assembling external O-rings

## Advantages

- Specifically designed with an independent device which expands the gasket and another which subsequently ejects it for assembling.
- Ability to assemble particularly thick gaskets and to position them in seats which are located at a distance from the ends of the housing.
- Adjustable stroke suitable for different O-ring sizes.
- Robust lightweight housing made of hard-coated aluminum alloy.

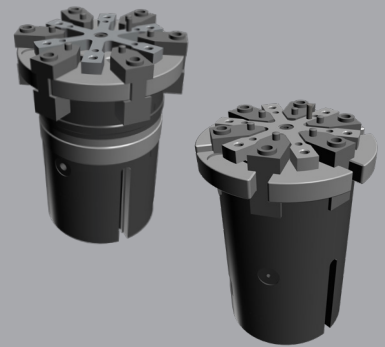

## SPECIFICATIONS

Model	Nr. of Jaws	Stroke Per Jaw*	Ejector Stroke	Theoretical opening force per jaw @ 6 bar	Ejector force @ 6 bar	Weight	Repeatability
PM06 - 3	6	1.75 - 8 mm	7.5 mm	158 N	570 N	1.3 kg	± 0.05 mm
		0.07 - 0.31 in	0.29 in	35.52 lb	128 lb	2.86 lb	±0.0020 in
PM06 - 4	6	8 mm	7.5 mm	158 N	570 N	1.2 kg	± 0.05 mm
		0.31 in	0.29 in	35.52 lb	128 lb	2.65 lb	±0.0020 in

\* Adjustable stroke only available for PM06 - 3

Operating Pressure **4 - 8 bar (58 - 116 psi)**  
 Working Temperature **5 - 60 °C (41 - 140 °F)**  
 Noise Emission (Sound Pressure) **<= 70 db(A) in any direction**

## SECTIONAL DIAGRAM

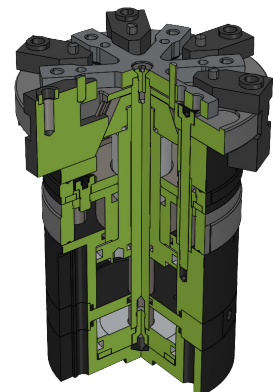
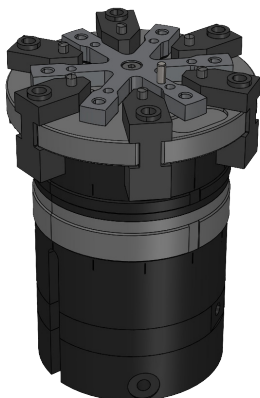

PM06 - 3

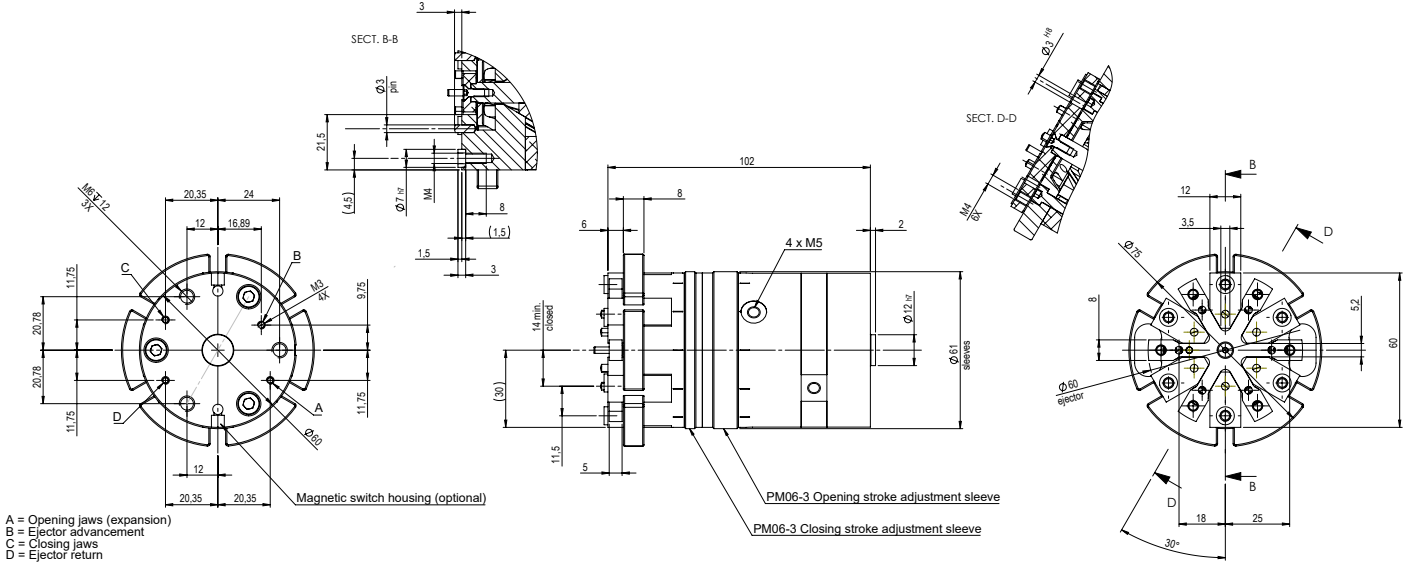

PM06 - 4

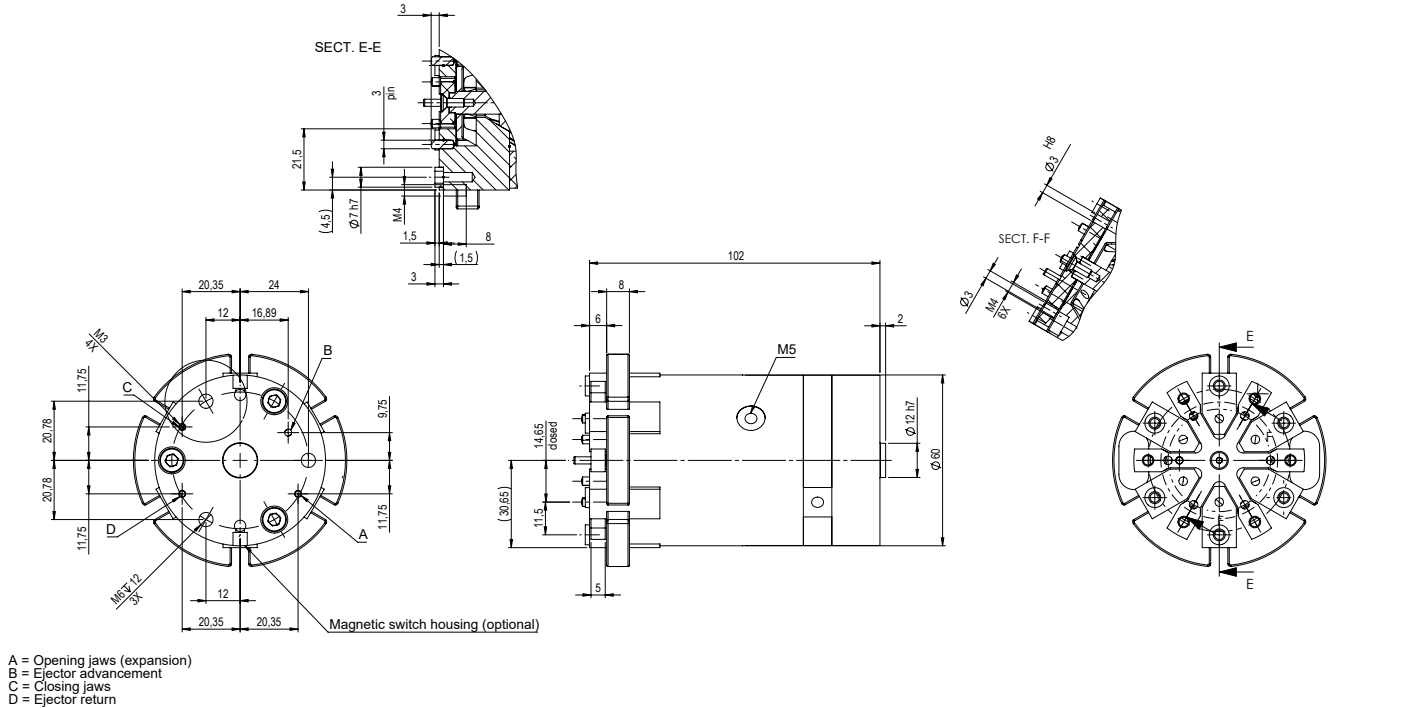

\* Dimensions are in millimeters.  
 \*\* All dimensions are descriptive and subject to variation for technical upgrading. We reserve the right to make variations without prior notification

**Applied Robotics**  
 A COMPANY OF EFFECTO  
 Applied Robotics  
 648 Saratoga Road  
 Glenville, NY 12302 USA  
 Tel. +1 518 384 1000 Fax +1.5183841200  
 info@appliedrobotics.com  
 www.appliedrobotics.com

**EFFECTO**  
 EFFECTO GROUP S.p.A.  
 Via Roma, 141/143  
 28017 San Maurizio d'Opaglio (NO) - Italy  
 Tel. +39 0322 96142 Fax +39 0322 967453  
 info@effecto.com  
 www.effecto.com

**EFFECTO**