

5. Refilling

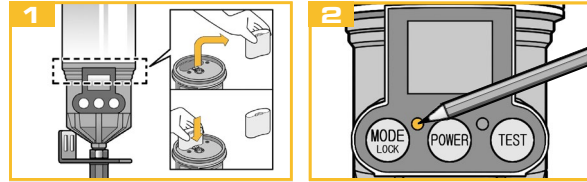

The batteries must be changed after each complete emptying of the oil reservoir.

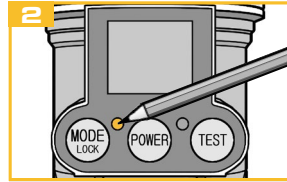

After changing the battery, reset the unit by pressing the RESET button and then reset the dispensing time.

6. Mounting

Direct mounting is always preferred.

If the application does not allow direct mounting, remotely assemble the unit using appropriate accessories and keep the distance from the lube point as short as possible.

For **remote installations** use a 6 mm (outer diameter) tube pre-filled with the same or compatible oil as the oil contained in the unit.

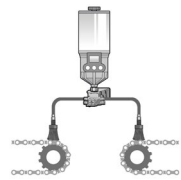

Multiple point installation is possible using a progressive distributor. Do not block any connections to the progressive distributor. Instead use a suitable distributor in accordance with the number of lubrication points. Keep the distance between the distributor and the lubrication unit as short as possible.

7. Important information

- The lubricant dispenser is **not** suitable for use with grease.
- Minimize tube resistances. Narrow passages and right angles should be avoided.
- During operation of the device a visual inspection of the device as well as of the lubrication point must be carried out regularly.
- Product warranty is limited to original defects in material and workmanship and does not cover any collateral damage due to mishandling, abuse and/or any other inappropriate use of the device.
- The maximum storage temperature should not exceed +40 °C (+104 °F). Higher temperatures decrease the battery's lifespan. The lubricator has to be activated within two years from receiving.

8. Troubleshooting

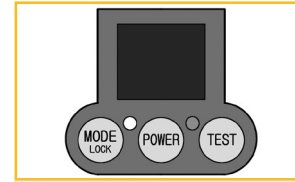

Control panel display:
Blank LCD screen
Cause:
Electrical malfunction of the CPU or the circuit, battery problem

Remedy:
Replace battery and/or press RESET button to restart the lubricator. If the problem persists, contact your supplier.

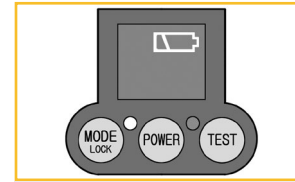

Control panel display:
Low battery power
Cause:
Voltage drop of the battery due to improper storage or demanding operating conditions (temperature, humidity or back pressure).

Remedy:
Always store the batteries in a cool, dry place and only use original batteries. Lithium batteries are also available as an option for demanding applications.

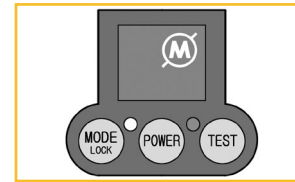

Control panel display:
Overpressure
Cause:
Excessive back pressure due to over-lubrication, interrupted, blocked or too long lubrication lines, etc.

Remedy:

- Check the back pressure at the lubrication point and/or at the lubrication line,
- if necessary, reduce the running time setting,
- if necessary, reduce the length of the lubrication line,
- or check the lubrication lines for possible blockages.



G LUBE OIL

User manual
G-LUBE OIL 500



1. Product details

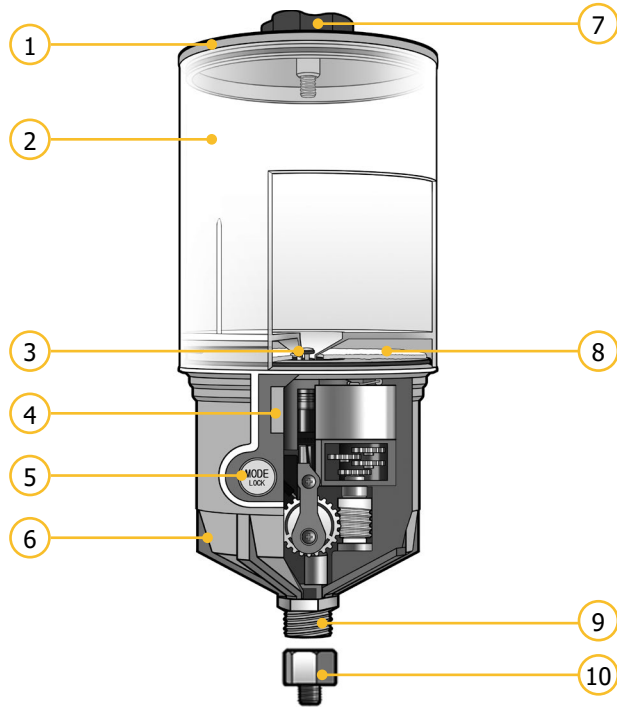

No.	Description	No.	Description
1	Cover for oil reservoir	6	Drive
2	Oil reservoir	7	Turning knob
3	Return valve	8	Nonwoven fabric
4	Display	9	Thread male 3/8"
5	Dispensing setting	10	Reducer 3/8" x 1/4"

2. Technical data

Housing			
Operating temperature	Alkaline battery: Lithium battery:	+5 ... +60 -15 ... +60	°C
Dimensions (height x Ø)	229 x 94		mm
Lubricant and hydraulic			
Lubricating medium	oil (> ISO VG 10)		
Lubricant volume	500 (refillable)		ml
Number of lubrication points	up to 10 by using progressive distributors*		
Max. operating pressure	10		bar
Oil delivery	per stroke	0,3 - 0,33	ml
Distribution period	0,5/1/2/4/6/12/18/24 months		

Electrics		
Working voltage (DC)	4,5	V
Protection class	IP54	

* The stated value depends on the individual application and may extensively differ in some cases (depending on the lubricant and further conditions).

3. LCD & key assignment

Key assignment	
	Dispensing time setting Unlock device (press down for 2 seconds)
	Switch device on and off (press down for 5 seconds)
	Test mode (ON: press for 2 seconds, OFF: press briefly - stops after the end of the current lubrication cycle)
	Reset to default setting when the unit is switched on or off (in the event of a malfunction or after refilling).

LCD-display	
	Dispensing time set
500	Oil reservoir capacity
	Device locked
	Test mode
	- 180
	2.77
	5603
	0403
	Overpressure / operation stopped
	Low battery power
	Oil reservoir empty

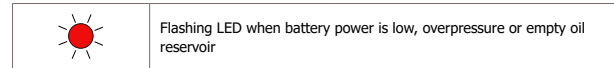

4. Installation



Remove the oil reservoir and nonwoven fabric and insert the battery. Put the nonwoven fabric back in and screw the oil reservoir back on.



Remove the lid of the oil reservoir and fill it up to the 500 ml level with oil.

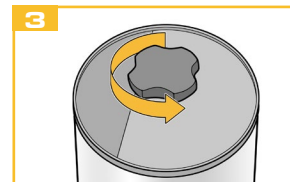

Turn the knob 1-2 turns counterclockwise before closing the cover and do not change the position again during operation.

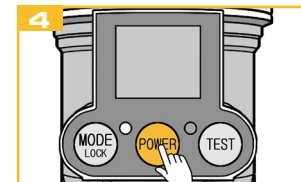

Press POWER for 5 seconds to switch on.

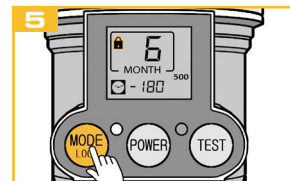

After 30 seconds, the key lock is activated. Press the MODE button for 2 seconds to unlock the unit.

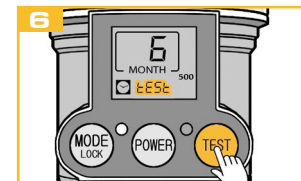

OPTIONAL: Press the TEST button for 2 seconds to perform a test run. Oil will leak out during the test run.

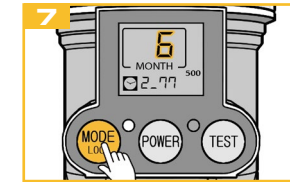

Press the MODE button several times to set the desired dispensing time. The display shows the amount of lubrication per day.

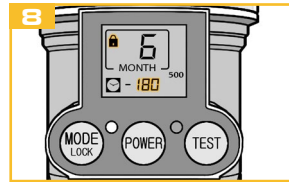

The lubricator is ready for operation. After the key lock has been activated, the remaining days of the runtime are shown in the display.

NOTE The oil in the equipment (hose/feed lines) and the oil in the unit should be the same or compatible.

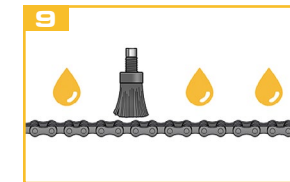

Ensure that a thorough pre-lubrication of the application is carried out before activating the lubricator.

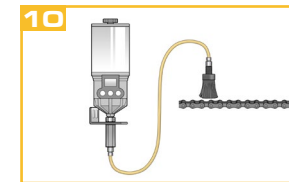

If the lubricator is installed below the lubrication point, make sure that the lubrication lines are filled.

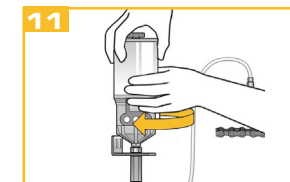

Fix the lubricator in the desired position.

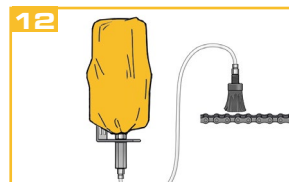

Pull the dust protection cover over the lubricator where necessary.