



Product Catalogue



COFIL

A COLOMBO FILIPPETTI COMPANY

Products & Solutions

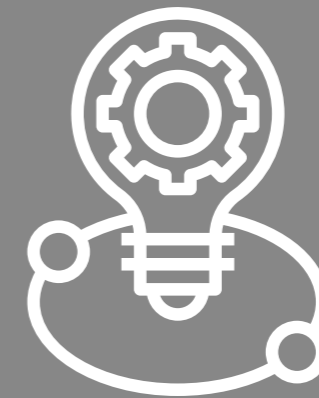
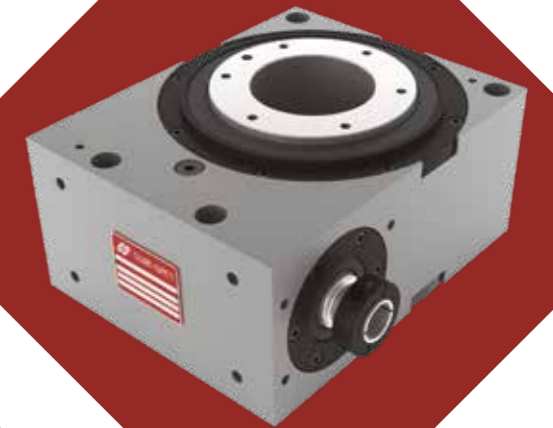

ideas of automation



Development of new projects in collaboration with the customers, attention, listening and knowledge of the markets. Our careful and continuous consultancy and ability to meet the new demands of an increasingly high-performance automation with the most remarkable technological profile. These are the distinctive traits of a business unit completely oriented towards the evolution needs of automation considering increasingly ambitious leadership goals that our clients continually arise. A team of engineers and designers always at your disposal to meet the most interesting challenges through ongoing dialogue aimed at the design and implementation of very high-performance customized mechanisms with specific and dedicated solutions. Welcome to the world of tailor-made collaboration, where technique reaches its peak of excellence.

Welcome to our business unit dedicated to speed in meeting the extremely varied automation needs of the most demanding customers. Solutions that are always ready and available, based on the wide availability of a range of standardized mechanisms in the catalog, which combine the high quality of Colombo Filippetti products with the flexibility in mounting options together with extremely fast supply times. Indexers, oscillators, rotary tables, manipulators and tool changers in the configurations that best meet current needs for precise, reliable and long-lasting handling. The increasing demand for mechanisms that can make automation solutions reach top performance in the widest array of industrial sectors. This is the meeting point between our superior production capacity and the most suitable solution provided to the customer



Product
OVERVIEW

◆ RIG

RIG04 - RIG06 - RIG09 - RIG19



The "RIGIDIAL" Indexing Tables are globoidal cam units used to transform a uniform rotary input drive into a series of equal output motions.

The indexing plate is supported by a large diameter cross roller bearing that withstand considerable axial and radial forces while retaining high levels of accuracy and rigidity. The globoidal cam ensures excellent wear resistance and the pre-loaded cam followers provide accuracy in positioning.

The indexing plate is available in three versions: with cover seal, fixed through hole and fixed central through hub. A version with an output ring for ceiling or inverted mounting is also available.

RIGIDIAL are available in four versions: RIG04, RIG06, RIG09 and RIG19 that allow transmitting torque from 93 Nm to 1.100 Nm, with the number of stops ranging from 2 to 32.

◆ CF3 Indexing and Oscillating Drives

Medium Series CF3 - 40P - 65P - 80P - 105P - 130P



The CF3 index and oscillating drives are double cam units having complementary profiles that transform a uniform rotary input motion into a smooth indexing or oscillating output motion.

Manufactured in five standard sizes with center distances of 40-65-80-105-130 mm between input and output shafts.

Torque capacities range from 20 up to 570 Nm. In the CF3 Index drives the standard number of stations is 1-2-3-4-6-8, and the cam index periods extend to 330° in 30° increments.

The CF3 Oscillating drives have standard angular strokes of 15° - 20° - 30° - 45°.

◆ RIGP

RIGP04 - RIGP06 - RIGP09



The RIGP Indexing Tables are mechanisms used to transform a uniform rotary input drive into a series of equal output motions.

The indexing plate is supported by a large diameter cross roller bearing that can withstand considerable axial and radial forces, while retaining high levels of accuracy and rigidity. The output disc has a central, fixed through hole for facilities.

Motorization is prearranged according to load capabilities. A double disc drives two proximity switches to stop unit in dwell position.

The globoidal nitrided cam, ensures excellent wear resistance, and the pre-loaded cam followers provide accuracy in positioning.

RIGP is available in three versions: RIGP04, RIGP06 and RIGP09, that allow transmitting torque from 93 Nm to 1.100 Nm, with the number of stops ranging from 2 to 12.

◆ CF3 Indexing and Oscillating Drives

Heavy Duty Series CF3 165P - 200P - 250P - 315P

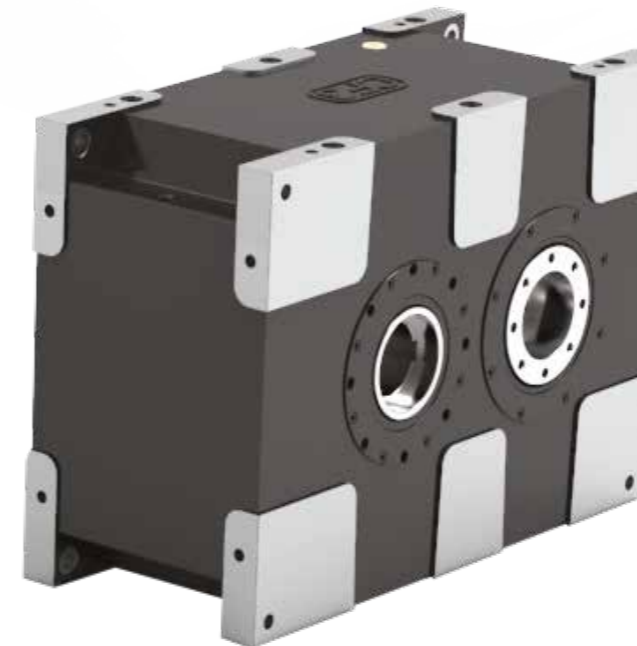

The CF3 heavy duty series indexing and oscillating drives are double cam mechanisms having complementary profiles that transform a rotary input motion into smooth indexing or oscillating output motion.

CF3 are manufactured in four standard sizes with centre distance between input and output shafts of 165-200-250-315 mm. Torque capacities range from 970 up to 6.610 Nm.

In the CF3 Index drives the standard number of stations is 1-2-3-4-6-8 and the cam index periods extend to 330° in 30° increments.

The CF3 Oscillating drives have standard angular strokes of 15° - 20° - 30° - 45°. Not included in the catalogue and made on customer's requirements are the CF3 400P - 500P - 650P.

◆ Globoidal cam indexing and oscillating drives CF4

CF4 50G - 65G - 80G - 105G - 130G - 165G - 200G - 250G - 315G



The CF4 INDEXING and OSCILLATING DRIVES are globoidal cam mechanisms that transform a uniform rotary input motion into a smooth indexing or oscillating output motion.

The range comprises of nine standard sizes from 50 to 315 mm centres distance between input and output shafts.

Torque capacity ranges from 30 to 13.000 Nm.

In the CF4 index drives the standard number of stops range from 2 to 24 and with index periods up to 330° in 30° increments.

The CF4 oscillating drives have standard angular strokes of 30°, 45°, 60°, 90°, 120° and 150°.

◆ Indexing rotary tables cylindrical cam IR

IR heavy-duty series IR1001 - IR1301 - IR1601 - IR1801 - IR2001

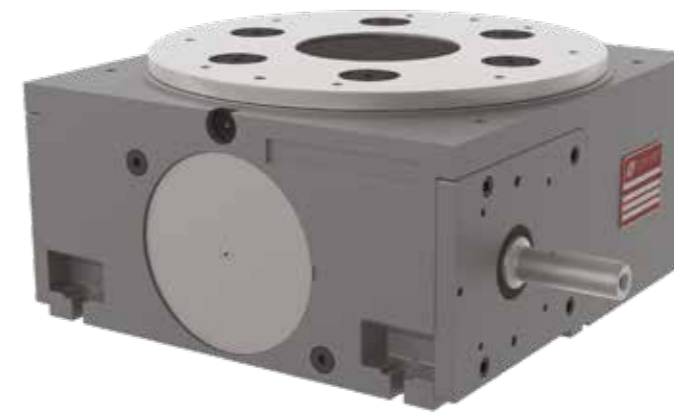

The heavy-duty series IR Indexing Rotary Tables are mechanical cylindrical cam units that transform the uniform rotary input motion into an indexing motion of the dial plate, which is supported by a cross roller bearing of large dimensions.

The IR1001 and 1301 with dial plates of, respectively, 1000 mm and 1300 mm, allow transmitting torque up to 49.850 Nm.

The standard number of stations ranges from 2 to 24 and the cam indexing periods are 270°, 310° and 330°.

The IR1601, IR1801 and IR2001 have an output plate with diameter up to 2 m and allow transmitting torque up to 180.000 Nm.

The standard number of stations of these tables ranges from 18 to 34 and cam indexing periods are 300° - 310° - 330°.

◆ Indexing rotary tables cylindrical cam IR

IR medium series IR201 - IR251 - IR301 - IR401 - IR601 - IR801



The IR Indexing Rotary Tables series are mechanical cylindrical cam units that transform the uniform rotary input motion into an indexing motion of the dial plate.

They are manufactured in six different versions from 185 to 620 mm plate diameters that allow transmitting torque from 40 to 12.500 Nm.

The standard number of stations ranges from 2 to 16 and the cam indexing periods are 270°, 310° and 330°.

◆ Rotary manipulators MAN

MAN10 - MAN20 - MAN30 - MAN40 - MAN50



The MAN family of manipulators, features a single piece cam which combines both a globoidal and a flat cam.

It turns a single uniform rotating input motion into an appropriate and ordered series of output movements, linear intermittent and rotating or oscillating intermittent of the output shaft, on which the gripper devices are installed.

The manipulators are characterised by accuracy, speed and smoothness of the movements, low vibration, simple construction, and compactness. Installation is easy and there is ample diversification of the output shaft movement cycles. These features grant reliability and flexibility of use in applications that include machine loading-unloading, handling in assembly operations and transfer to conveyor belts.

They are available in five frame sizes: MAN10 - 20 - 30 - 40 - 50 with 45 - 65 - 85 - 110 and 165 mm max. linear stroke and angular rotation up to 180°.

COFI
GO

◆ Cam tool changers CUT

CUT31 - CUT41 - CUT51 - CUT32 - CUT42 - CUT52



The CUT series tool changers are mechanical cam units that transform a uniform rotary motion of the input shaft into a composite motion of the output shaft.

The synchronised combination of rotational and linear movements performed by the output shaft produces the cycle that carries out the rapid interchange of tools between magazine and machine spindle. CUT are manufactured in three frame sizes CUT31, CUT41 and CUT51. Mirrored versions CUT32, CUT42 and CUT52 are also available.

The tool changer gripper double-arm has an automatic lock for holding the tools during the transfer phase. Gripper arms are available for various tool exchange centre distances from 300 to 850 mm, and for ISO, HSK and CAPTO tapers.

◆ Cam driven tool changer VTC (vertical tool changer)

VTC40

The VTC is a vertical tool changer, a mechanism that gives the complete tool changer motion cycle within compact overall dimensions. Both exchange time and rigidity are improved.

VTC is currently manufactured for size 40. Typical taper tools are ISO 40 and HSK 63. The linear stroke goes up to 110 mm.



COFIL
GO

◆ Cam tool changers HTC

HTC140 - HTC40 - HTC50



The HTC (Horizontal Tool Changer) devices are mechanical, machine-independent tool changer assemblies which, by means of a cam drive, transform an incoming uniform rotary motion supplied by a gearmotor into a regular series of stop-and-go linear and rotary movements of the output shaft onto which the gripper arm is fixed.

The synchronous combination of movements performed by the gripper arm provides the typical tool change motion cycle.

Currently manufactured in three frame sizes: HTC140 - 40 - 50 for tools with ISO30 - 40 - 50 and HSK63-80-100 taper.

The gripper arm has an automatic lock for the tools during motion. Exchange arms are available for various tool exchange centre distances from 470 to 580 mm and made for tool from 10 to 25 Kg.



Empowering your
SERVO

◆ RIGS Servo Units

RIGS04 - RIGS06 - RIGS09

RIG SERVO UNITS are based on the well known RIG tables line.

The Rig Servo units match the high load capacity of the wide rigid output disc with a precise, backlash free and preloaded constant velocity cam. This results in units with high dynamic performances and high precision.

The Rig Servo units are pre-arranged to mount specific servomotors and are user programmable.



◆ SRP Servo Roller Positioner

SRP100

The Servo Roller Positioner SRP is based upon a simple but effective design characterized by a compact aluminium housing with flat surfaces for ease of assembly, an output rigid turning turret with a wide central through hole supported by a pair of oversized radial roller bearings and a precise, preloaded constant velocity globoidal cam.

The cam design and the preload between cam and output turret allows for a high rigid, precise and backlash free unit in any position. The Servo Roller Positioner grants reliability, high dynamic performance, flexibility, smoothness of motion and efficiency.

The unit is pre-arranged for standard specific and user programmable servomotors.

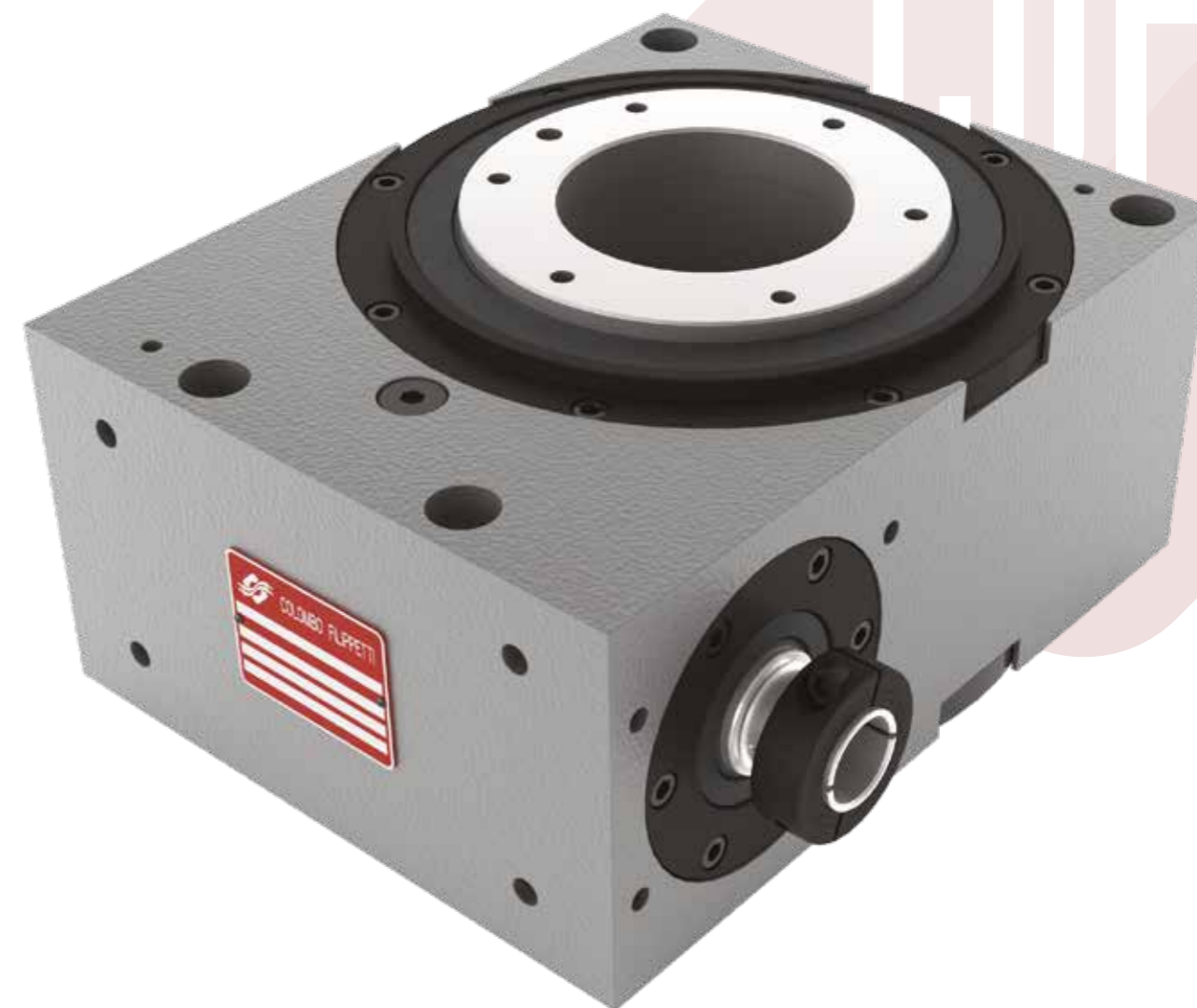

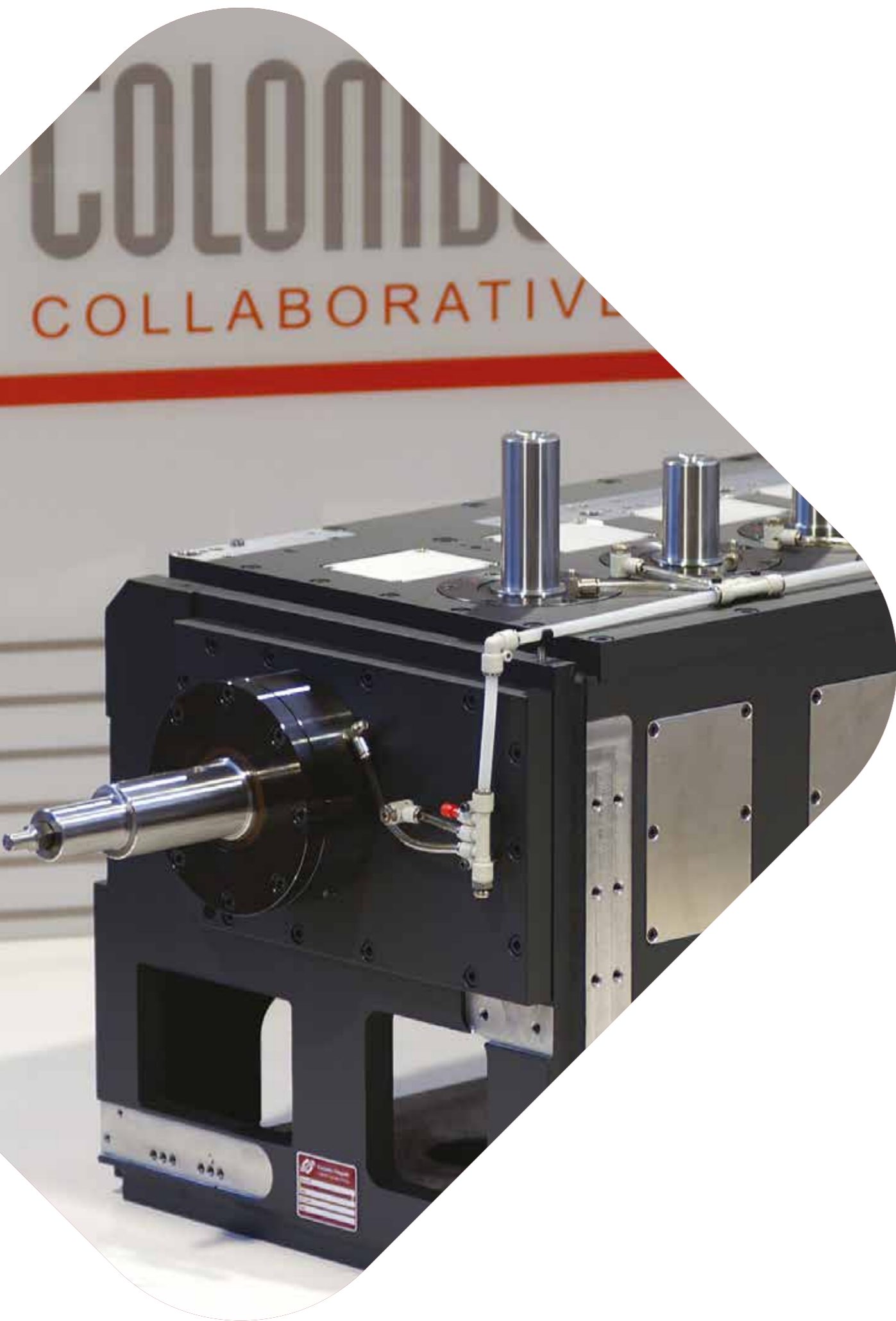

◆ CF3 Tandem Parallel Shafts

CF3 65T - 80T - 105T - 130T



The CF3 TANDEM are units achieved by combining in one box, two double set of CF3 conjugate cams and their respective follower turrets.

The uniform rotation of the input shaft is transformed by this unit into 2 intermittent rotary motions of the output shafts.

Each intermittent output shaft can be unidirectional or oscillating.

There is a free choice and it is possible to have:

1 indexing rotation + 1 oscillating rotation (indexing+oscillating)

2 indexing rotations (indexing + indexing)

2 oscillating rotations (oscillating + oscillating)

Tandem are manufactured in four standard sizes 65T, 80T, 105T and 130T, with torque capacities that range from 45 up to 970 Nm.

The standard number of stations is 1, 2, 3, 4, 6 and 8, while the cam index periods extend to 330° in 30° increments.

The oscillating drives have standard angular strokes of 15°, 20°, 30° and 45°.

◆ Rotary manipulators H..S

H65S - H80S - S105S - H130S



The rotary manipulators of the H-S series are double cam mechanisms which transform the uniform rotary motion of the input shaft into, respectively, intermittent rotary and linear motion typical of the pick and place cycle.

The standard rotary manipulator has an angular oscillation of up to 90° or an index of 180° together with a linear stroke of up to 120mm. It is possible to use a load support arm up to 500 mm long.

◆ Linear manipulators H..T

H65T - H80T - H105T



The linear manipulators of the H..T series are flat conjugate double cam mechanisms that transform the uniform rotary motion of the input shaft into a two-way linear oscillating motion typical of pick and place movements.

They are manufactured in three different sizes H65T, H80T and H105T and in two special long traverse versions H80TL and H105TL and are all based on the CF3 TANDEM units.

With the standard linear manipulators it is possible to perform traverses up to 480 mm in a longitudinal direction, up to 120 mm in a transverse direction..

◆ MG3 Three-axis manipulator

MG3 180



The MG3 manipulator combines one rotary motion and two linear strokes on the same output axis to reach high speed, accuracy positioning, repeatability and a quiet operation.

The three movements of the output axis are then combined by means of custom-specific linkage to obtain the desired motion of the end effector.

The heart of the MG3 manipulator is a globo-conical cam that thanks to its shape allows for compactness and in a limited space a third axis has been added.

COFIL
PRO

◆ HTC cam tool changer plus door operator

HTC40T

In most machining centres with horizontal spindle axis, it is normal for the tool-magazine to be in a protected area of the machine.

This area is generally separated from the working area by means of a bulkhead in which there is a door opening. Only when exchange of tools is made, is the door opened and closed.

For the fastest tool exchange time, the door movement in the bulkhead must be synchronised with the movement of the tool changer.

HTC is equipped with an extra output shaft that is used for rapid opening and closing of the door in perfect synchronisation with the tools exchange motions.

This evolution of the HTC40 mechanism is known as HTC40T.



◆ Special projects for customized solutions

Our success exists most of all in collaborating with our customers, understanding their requirements, analysing the precise problem and creating possible solutions even the most unexpected or resourceful. It is in this context that we develop our industrial project towards satisfying new requirements in mechanical automation with design and manufacture of any kind of cam and cam mechanism.

Parallel axes mechanism with flat cams.



Horizontal axes linear precision conveyor.



Barrel cam for high linear stroke.

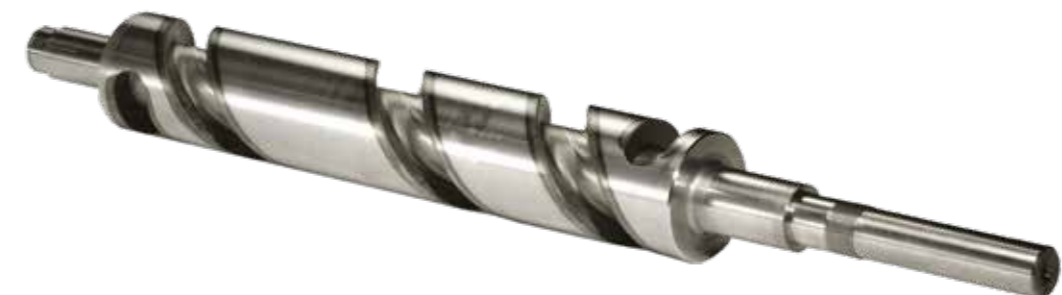

COFI
DRO

Globoidal cam mechanism with four synchronised output motions each having double ended output shafts.



Globoidal cam mechanism with two synchronised oscillating movements.



Complex cam mechanism with various types of cams that produce seven indexing movements and synchronised oscillating outputs.

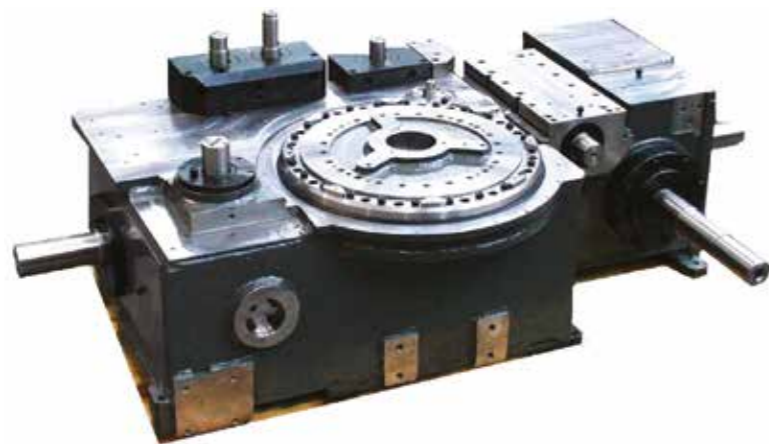



High performance
CAMS

◆ CAMS

With decades of experience in cam design and manufacturing COLOMBO FILIPPETTI offers its customers the best support possible in application engineering, design and development.

Thanks to the continuous research in technology, Colombo Filippetti can produce most types of cams to customer's drawings and specifications and certify the precision when required.

Cam profile such as slotted, single or complementary; complementary simple or double cams with ribbed profiles; and more specifically, cams with flat, cylindrical, conical, globoidal, spherical, three dimensional, z-shaped, inverse, screw profiles, etc...

Cams are produced up to diameter of 2.500 mm and a length of 3.000 mm; profile finishing ranges from simple milling to precision grinding after heat treatment, with surface finishes to 0.2 Ra.



◆ Spherical cams

SPHERICAL CAMS

The sphero-conical cam characteristic is to develop wide oscillating angles in the minimum overall dimensions.

The sphero-conical cam was patented for use in the textile industry. Assembly machines also employ cams in mechanical pick and place manipulators for automatic assembly.



◆ Flat cam with conjugated profiles supported by a cross roller bearing.



◆ Combination of flat cam and globoidal profile cam.



◆ Sphero-conical cam design

FASTER SPEEDS, HIGHER EFFICIENCY AND
MAXIMUM RELIABILITY FOR YOUR PRODUCTION MACHINERY!

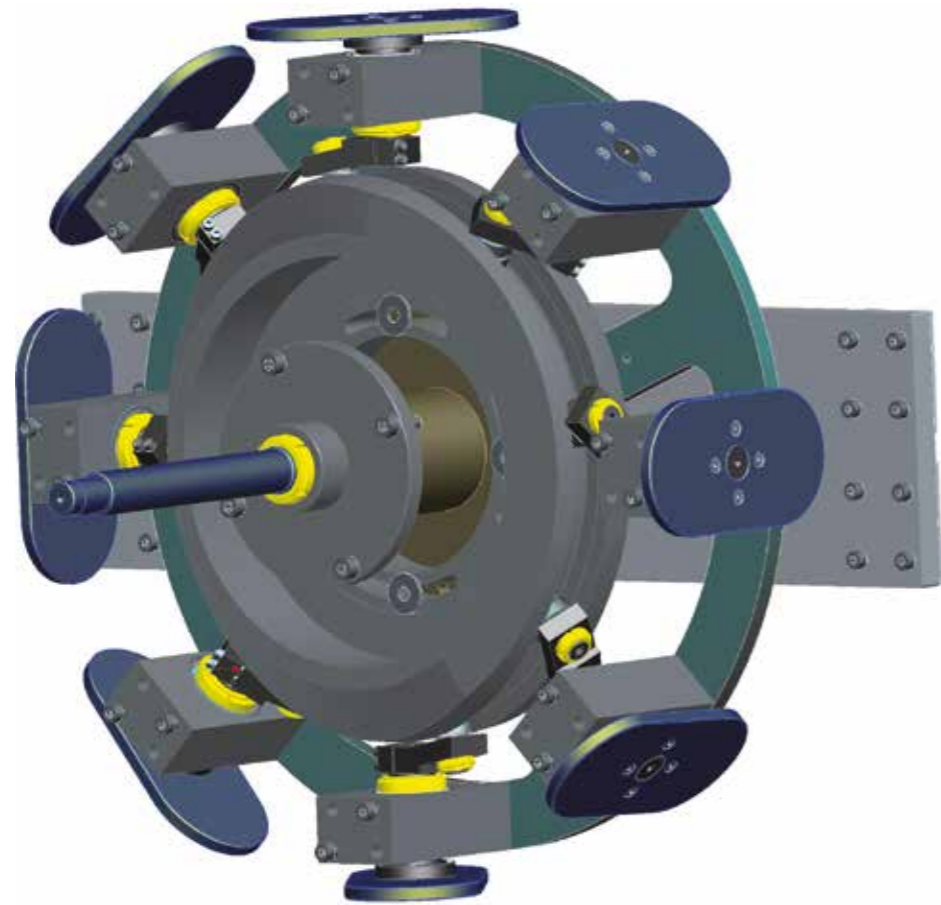

The typical geometric shape of sphero-conical cams provide the best efficiency in motion conversion and ensure faster work speeds than can be achieved by other comparable mechanical cam solutions.

Typically cylindrical cam designs are used for this purpose, but the height of engagement between the cam profile track and the follower varies during rotation. This variation introduce unwanted axial movements into the motion profile.

Whereas in sphero-conical cams the cam follower is completely in contact with the profile track during the entire rotation.

This constant engagement prevents any axial movement of the cam follower which in turn increases working speeds, improves efficiency and provides longer life.

An additional important benefit of the Colombo Filippetti Sphero-Conical cam design is that routine maintenance is not required.

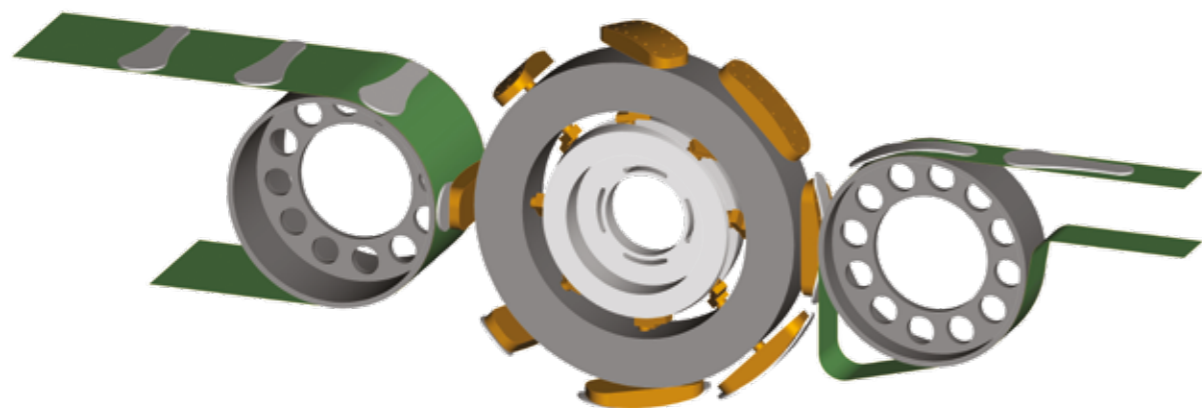

◆ Multi-section cam for high speed & performances



The cam's motion profile is achieved by combining the individual sections of the cam as a complete assembly. This unique design allows the cam's motion profile to be machined in two different ways.

The cam's motion profile can be machined after each of the individual sections have been assembled as a complete unit and mounted to a supporting flange. Another option is the motion profile can also be machined into each section separately and then final assembled as a single complete cam which would be mounted on a central hub or supporting frame.

In both processes, the cam's motion profile will guarantee a high degree of positional accuracy and smooth repetitive motions. Benefits of a multi-sectional cam:
Motion profile sections can be easily replaced for quick product or format changeovers. Individual sections of the cam can be replaced which are subject to high stress levels. Individual sections allow cams to be assembled onto existing shafts together with other mechanical mechanisms while avoiding to disassemble other components for fast & easy installation.

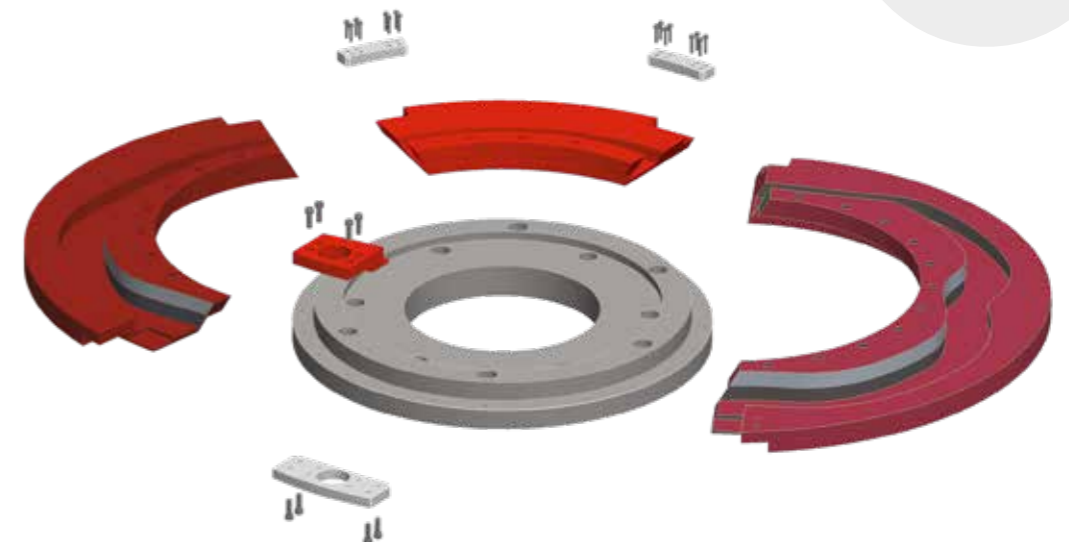

◆ Inner barrel cam in one part for better assembly & speed

The cam follower located in the inner central hole of the cylindrical barrel cam is particularly suitable for compact applications with a restricted available space.

The cam follower can be either sliding or pivoting.

It must be noted that large diameter cam followers can be used compared to the central hole.

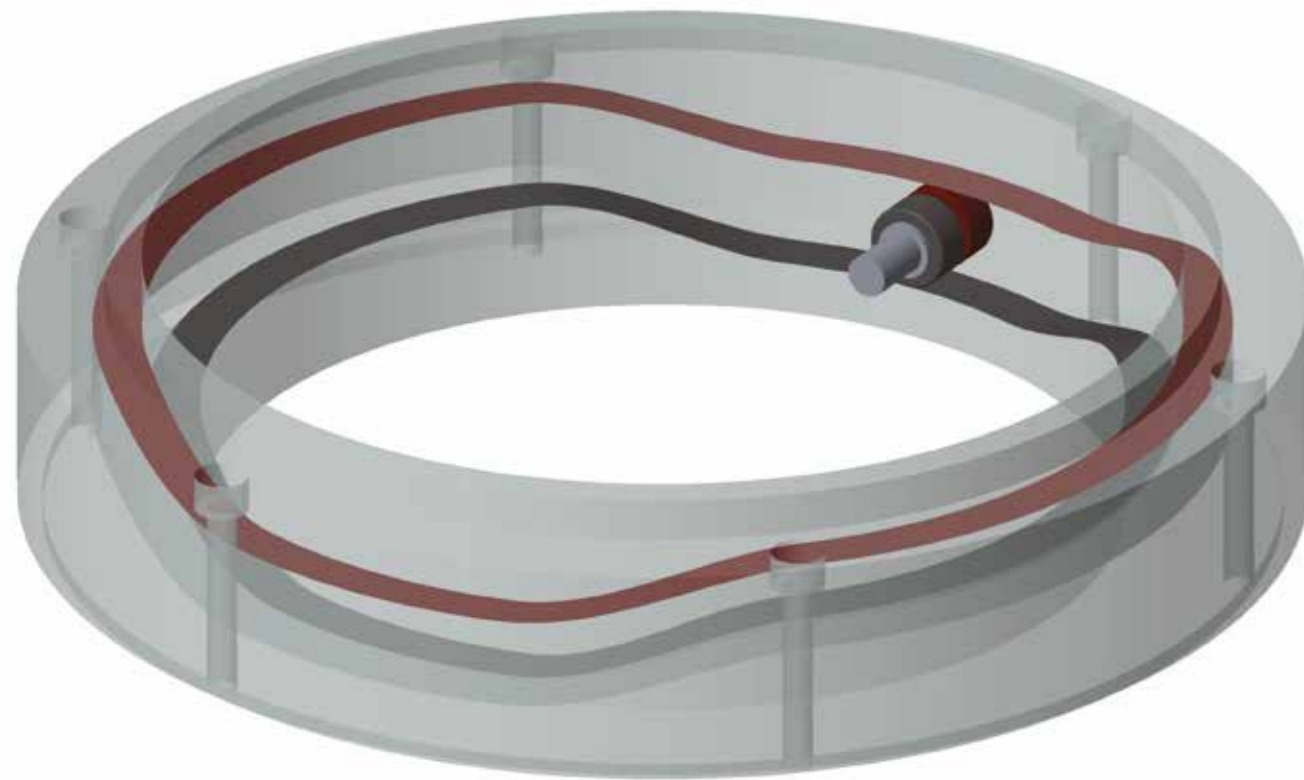

◆ Multi-section cam for high speed & performances

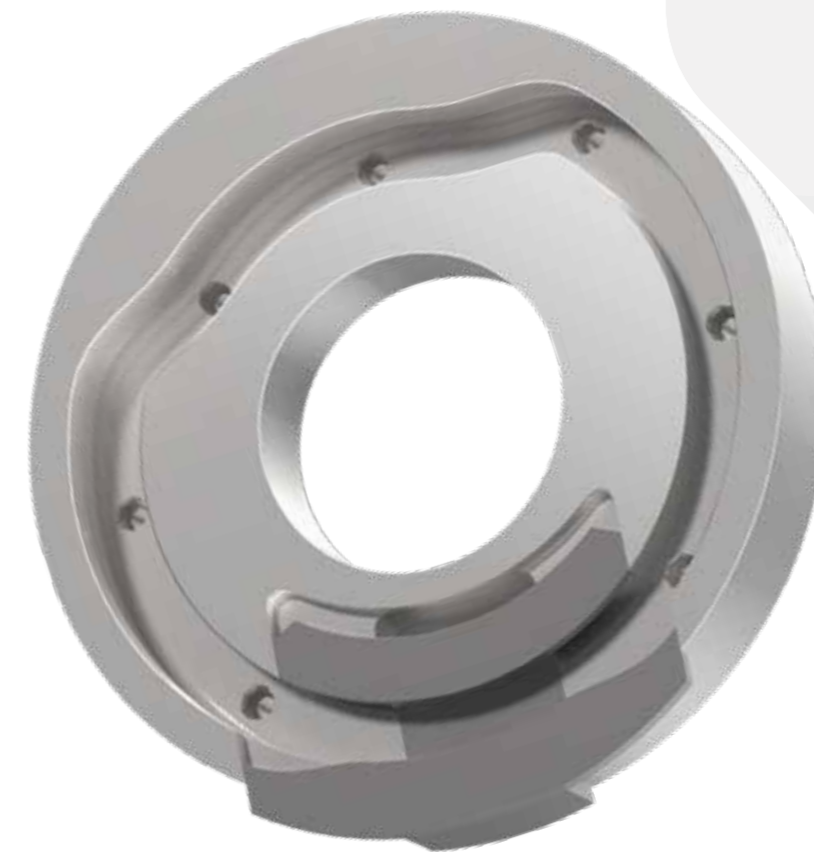

The cam is equipped with an adjustable section either sliding along a radial direction or pivoting on a hinge.

Adjustable section helps:

- Changes in size forma
- Temporary modification of the part working proces
- Separate faulty parts

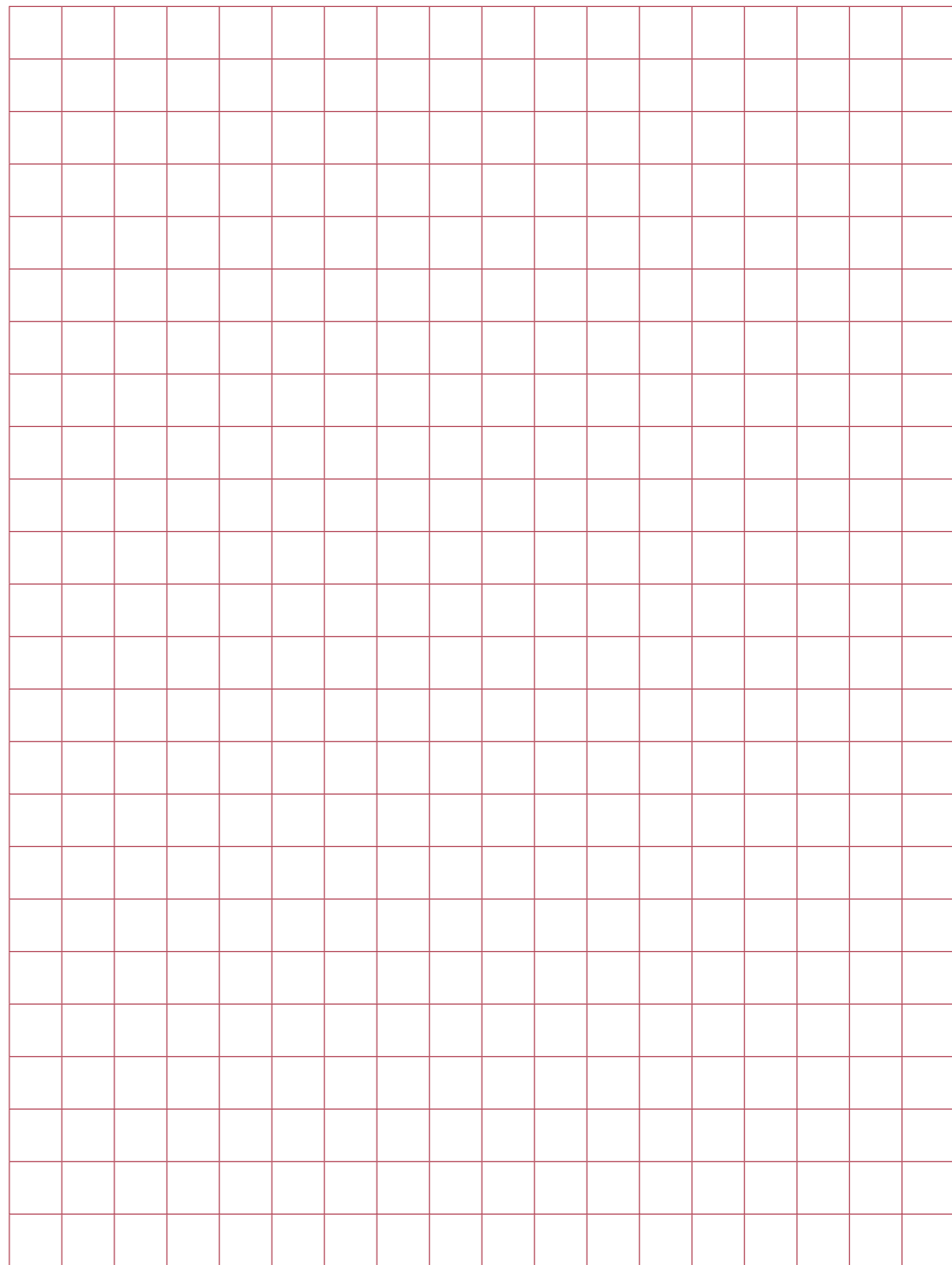
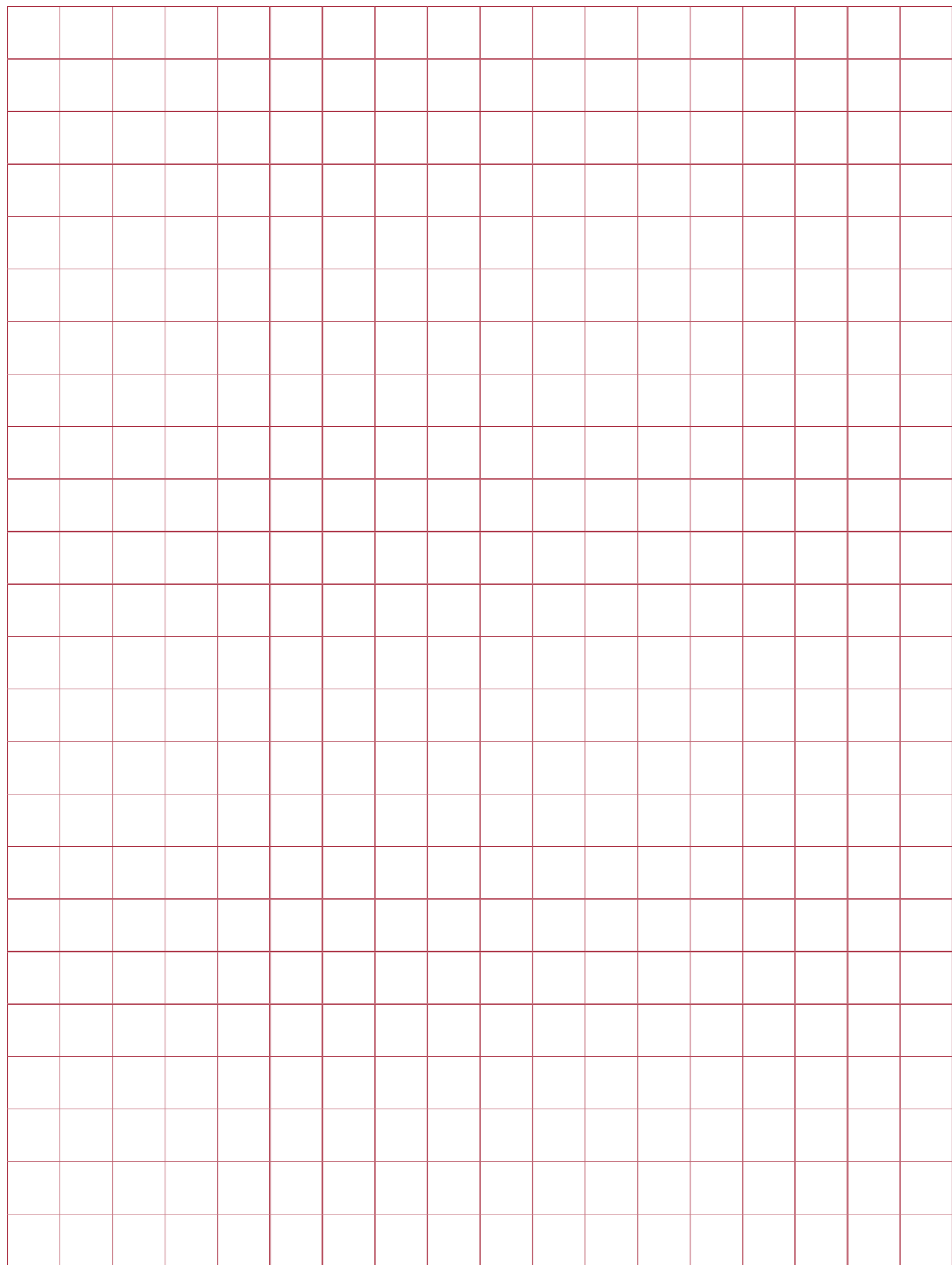

HEADQUARTER

◀ ▶ COLOMBO FILIPPETTI SPA

Via G. Rossini, 26 - 24040 Casirate D'Adda- BG - Italy
Phone +39 0363 3251 - Fax +39 0363 325 252

SUBSIDIARIES

CoFil Inc

2175 Point Boulevard Suite 170 Elgin, IL 60123 - Usa
Phone +1 847 844 0114

CoFil GmbH

Rudolf-Diesel-Straße 11 69115 Heidelberg - Germany
Phone +49 170 924 9524

◀ ▶ GATE FRANCE S.A.R.L

15 Grand Rue, 68320 Jepsheim - France
Phone +33 389 216 867 - Fax +33 389 216 999



www.cofil.com

