



**GRUETZNER**  
AUTOMATIC LUBRICATION

# PRODUCT CATALOGUE















## AUTOMATIC LUBRICATION

Edition 12/2021

*modern lubrication technology*



## Content

<b>Automatic lubrication</b>	3		<b>Lubricants</b>	24	
<b>G LUBE</b>	4		<b>Accessories</b>	26	
<b>SOLOLUBE</b>	6		<b>Distributors</b>	31	
<b>LUB 5</b>	8		<b>Lubrication gears &amp; pinions</b>	33	
<b>G LUBE VIB</b>	10		<b>Brushes &amp; rolls</b>	37	
<b>LUB-S</b>	12		<b>Gruetzner sets</b>	39	
<b>LUBRICUS</b>	14		<b>Model scheme</b>	41	
<b>LUB-Z</b>	18				

### Gruetzner GmbH

Gruetzner GmbH is your specialist for automatic lubrication systems since 1993. Our user-friendly lubrication solutions are used in almost all areas of maintenance in every industry across the globe.

As an international established, family-owned enterprise flexibility and outstanding service are our core competencies. An individual, custom-built lubrication concept which is adjusted to your machines and constructions will gladly be developed by our experts.



## Bearing damage and its causes

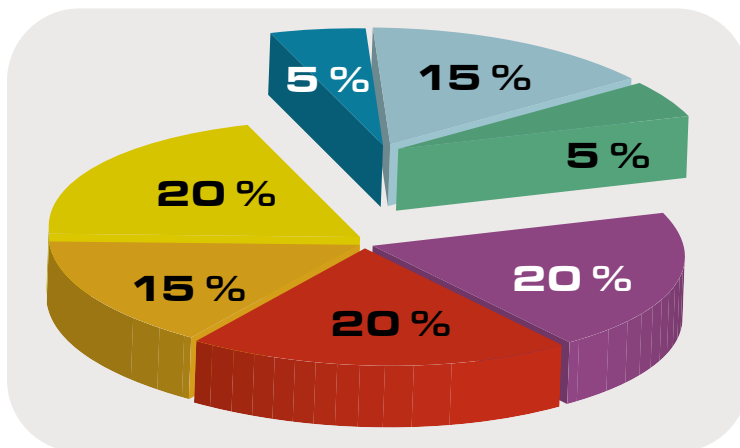

- old lubricant
- not enough lubricant
- unsuitable lubricant
- solid impurities
- liquid impurities
- incorrect construction & assembly
- consequential damage

**More than half of all unforeseen bearing malfunctions are lubricant related!**

In 75% of cases, automatic lubricant dispensers help prevent bearing malfunction.

## The benefits of automatic lubricators

Automatic lubrication systems dispense small, precise amounts of lubricant at short, regular intervals.

The amount of time and personnel required for large plants, and machines located in hazardous areas mean that manual lubrication is often dangerous, impractical and expensive. Automatic lubrication systems as part of maintenance can resolve this issue.

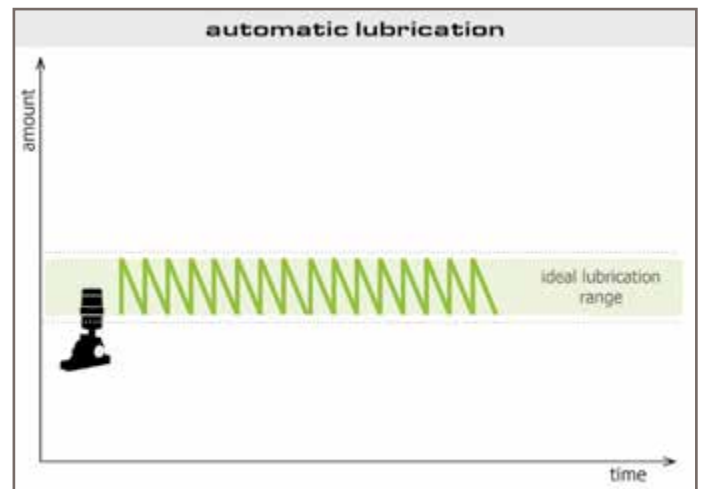
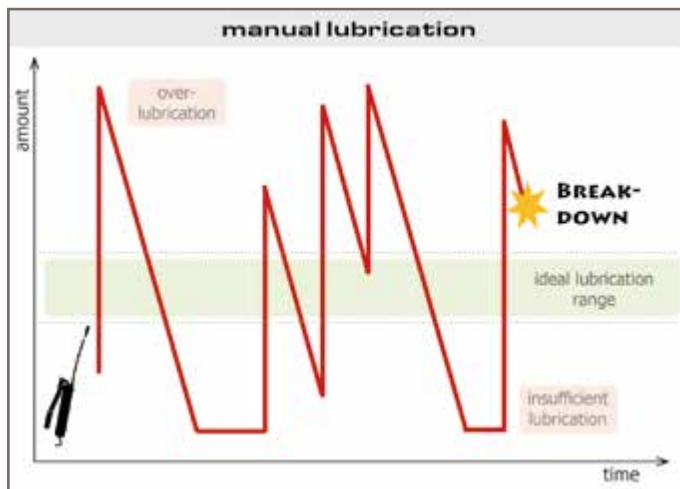

Automatic lubrication systems prevent under- and over-lubrication, thus enhancing the service life of your machines.

## Automatic lubrication...

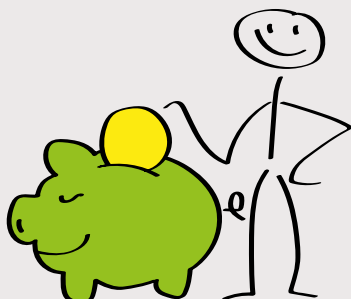

### ...reduces your costs

- saves time
- fewer machine breakdowns due to decreased wear
- lower lubricant consumption
- increased service life of bearings

### ...protects the environment

- needs-based lubricant dosage
- low risk of impurities and contamination

### ...improves work safety

**...enables monitoring and provides an overview**

# G LUBE



## G-LUBE - cost-effective, reliable, safe, ecological

G-LUBE is an electronically controlled single-point lubrication system, driven by a chemical reaction.

The dispenser excels through user-friendliness and a good cost-performance ratio. This product is the right choice for most lubrication applications: cost-effective, reliable, safe and ecological!

### Automatic lubrication through an electrochemical drive

G-LUBE combines all the advantages of gas-powered lubrication systems and is a cost-effective solution for users wishing to switch from manual to automatic lubrication and for those familiar with automatic lubrication systems.

The function is based on the proven technology of an electrochemical reaction that produces non-reactive nitrogen ( $N_2$ ) through the systematic use of an electrolyte. This type of pressure generation makes G-LUBE more temperature-independent than many conventional gas-powered lubrication systems.

With pressure generation not exceeding 5 bar (73 psi) and at ambient temperatures from  $-20\text{ }^{\circ}\text{C}$  to  $+55\text{ }^{\circ}\text{C}$  G-LUBE guarantees up to 12 months of reliable operation. The lubrication system is available in the sizes 60, 120 and 240 ml.

### Benefit from the G-LUBE advantages

- Electrochemical drive
- Precise, reliable lubricant delivery
- Easy handling
- Activation without tools
- Environmentally friendly product, easy disposal
- Can be used outdoors
- Can be used in EX areas
- Dispensing period 1/3/6/9/12 months (modifiable at any time)
- Easy and fast to fill yourself
- Special fillings possible



## Design

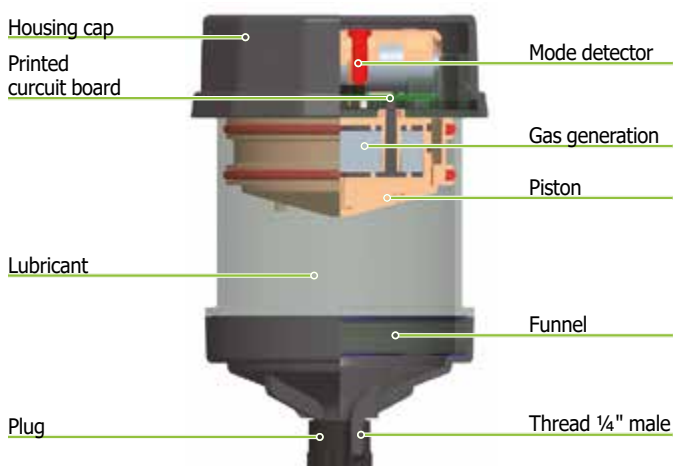

## Technical data

Model	GL-60	GL-120	GL-240
Drive	electrochemical		
Operating pressure	max. 5 bar (73 psi)		
Distribution period	1/3/6/9/12 months		
Lubricant volume	60 ml	120 ml	240 ml
Lubricating medium	oils and greases up to NLGI 2		
Operating temperature	-20 °C to +55 °C		
Weight empty	~ 195 g	~ 205 g	~ 225 g
Dimensions (height x Ø)	91 mm x 77 mm	111 mm x 77 mm	156 mm x 77 mm
Distributor possible	-		
Certifications	ATEX, IP68		

## Filling - all-round service or independently

You can fill G-LUBE yourself in a few easy steps. Both oils and greases up to NLGI class 2 can be used.

Of course, you can always rely on our tried and tested standard lubricants (from page 22) or provide us with your own lubricant for filling.

Our all-round service is even more convenient: we take care of everything from the provision and filling of your desired lubricant to the delivery of the dispenser, ready for use.



### Self-filling

**You can refill G-LUBE yourself quickly and easily!**



G-LUBE can be used in almost all sectors and areas and can be activated without tools. For indirect installation, we recommend our extensive range of accessories on page 24 onwards.



# SOLOLUBE



## Sololube - precise electromechanical single-point lubrication

Sololube is a reliable, easy-to-operate lubricant dispenser with an electromechanical drive. Its precise delivery system makes Sololube equally suitable for the automatic lubrication of roller and friction bearings, gear racks, open transmissions or chains.

### Safe automatic lubrication

Sololube has a robust, very precise drive motor, supplied with voltage by a high-capacity 6 V Li battery or a 24 V power supply. The lubricant cartridge – optionally with 60, 150 or 250 ml content – is simply screwed to the drive unit.

With a delivery pressure of 7.5 bar (109 psi), Sololube works automatically and independent of temperature for up to a year. The dispensing period can be freely selected between 1 and 12 months (by altering the amount of lubricant dispensed). Changing the setting or switching the device off is of course possible at any time.

The performance of the Sololube is monitored with a clearly visible LED. The filling level of the lubricant cartridge is, moreover, clearly visible at all times through the transparent housing.

### Benefit from the Sololube advantages

- Precise, reliable delivery of lubricant
- Delivery pressure 7.5 bar (109 psi)
- Dispensing period 1–12 months
- Visual warning of malfunction (LED)
- Operating temperature -20 °C to +60 °C
- Can be used outdoors
- Independent of temperature
- Visual check possible at all times
- Hose up to 1.5 m long
- Special fillings available

### Models

Sololube is available in three models:

The **Xtra150** model uses a 150 ml cartridge. If a larger or very small amount of lubricant is required, **Xtra250** (250 ml) **Xtra60** (60 ml) apply. All models include a reusable electromechanical drive unit.



## Design

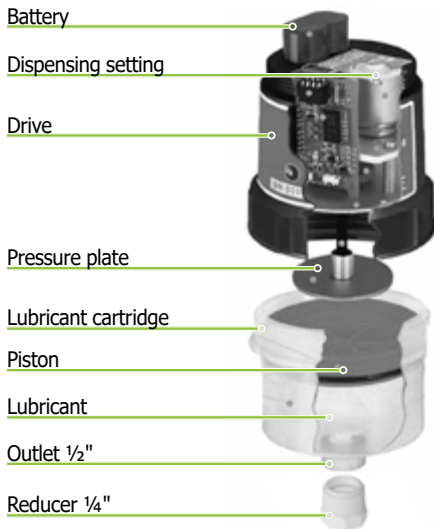

## Technical data

Model	Xtra60	Xtra150	Xtra250
Drive	electromechanical (reusable)		
Operating pressure	max. 7.5 bar (109 psi)		
Distribution period	1-12 months		
Lubricant volume	60 ml	150 ml	250 ml
Lubricating medium	oils and greases up to NLGI 2		
Operating temperature	-20 °C to +60 °C		
Working voltage	6.0 V (Li battery) or 24 V power supply		
Weight empty: battery/adaptor	~ 542 g ~ 563 g		~ 700 g ~ 730 g
Dimensions (height x Ø)	138 x 84 mm	151 x 84 mm	183 x 96 mm
Performance monitoring	green/red LED		
Distributor possible	-		

## Adapter for external power supply 24 VDC

In addition to classic battery operation, the Sololube lubricant dispenser is also available with external 24 V power supply.

Practical fact: With the 24 V adapter even customers who are already using the battery-operated device can easily and inexpensively switch to an external power supply.

The Sololube lubricant dispenser cap can be easily changed in seconds and intermittent machine-dependent operation is possible immediately. The adapter is connected using a two-core connection cable.



## Your gains

- ✚ No batteries, no follow-up costs
- ✚ Synchronisation with machine possible
- ✚ Sololube already in use can be retrofitted

## Installation

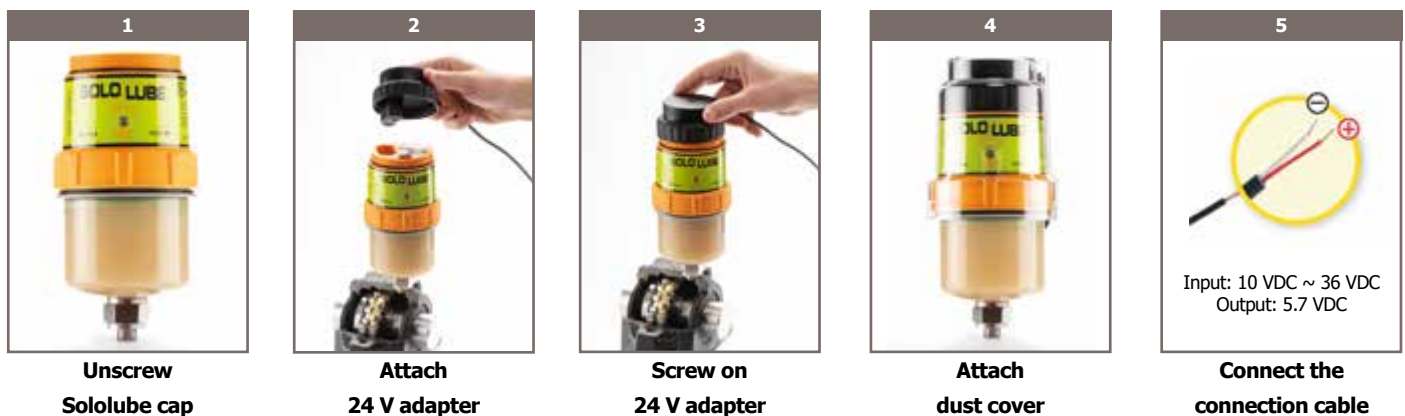

# LUB5



## LUB5 - electromechanical lubricator

LUB5 is an electromechanical lubricant dispenser designed to supply single lubrication points with oil or grease. The lubricant dispenser is intended for stand-alone operation as the energy supply is provided by an integrated battery pack. LUB5 is designed for a variety of applications for single point lubrication.

### Self-filling

The lubricant is stored in a refillable 120 ml or 250 ml reservoir. Maximum supply pressure is 10 bar (145 psi). LUB5 can be (re)filled quickly and easily at any time using a grease gun.

The battery pack has a total capacity of four years or four refills (depending on which occurs first). The dispensing period of LUB5 can be set to 1, 3, 6, 12 or 24 months.

### Benefit from the LUB5 advantages

- 3 versions available
- Electromechanical drive
- Delivery pressure 10 bar (145 psi)
- Up to 24 months per filling
- Refillable up to 4 times without any follow-up costs (*total 600/1250 ml or maximum of 48 months*)
- Self-filling possible
- Oil or grease up to NLGI cl. 2
- No additional tools required for operation
- Operating temperature -20 °C to +60 °C (*with suitable lubricant*)





## Design

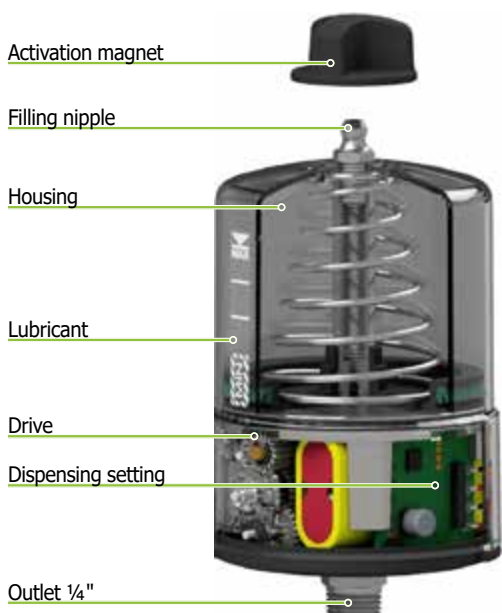

## Technical data

Model	LUB5-120	LUB5-120 PLUS	Lub5-250
Drive	electromechanical		
Operating pressure	max. 10 bar (145 psi)		
Distribution period	1/3/6/12/24 months		
Lubricant volume	120 ml	120 ml	250 ml
Discharges	max. 5 (=600 ml)*		max. 5 (=1250 ml)*
Lubricating medium	oils and greases up to NLGI 2		
Operating temperature	-20 °C to +60 °C		
Working voltage	3.0 V (Li battery)		
Battery capacity	standard	triple**	standard
Weight empty	~ 314 g	~ 490 g	~ 558 g
Dimensions (height x Ø)	127 x 70 mm	182 x 70 mm	243 x 70 mm
Performance monitoring	green/red LED		
Distributor possible	-		

\* 5 discharges or an operational period of 48 months (whichever comes first)

\*\* suited for high counterpressure and low temperatures

## Lubrication up to 24 months

The running time per filling is adjusted directly on the device. The remaining filling cycles are shown by LEDs.

Possible malfunctions are also shown via LEDs. When using the suitable lubricant, LUB5 can be emptied 5 times or used for an operating period of 48 months maximum.



### Easy filling

**LUB5 can be (re)filled easily and quickly by using a grease gun**



# G|LUBE VIB



## G-LUBE VIB - automatic lubricator with vibration sensor

G-LUBE VIB is an innovative electromechanical lubricator dispenser that only activates itself if the connected sensor registers vibrations. This makes it particularly suitable for intermittent operation. The battery power supply allows self-sufficient use and makes the G-LUBE VIB independent from an external power supply.

### Movement makes the difference



G-LUBE VIB is connected to a vibration sensor that is mounted quite easily on the relevant machine using a magnet.

The sensitivity of the sensor can be adjusted infinitely. During operation the G-LUBE VIB only lubricates in accordance with the entered settings if the sensor registers vibrations. This guarantees optimum lubrication even on machines that are not used regularly.

All functions are visible at all times on the built-in display.

### Models

G-LUBE VIB is available in the model versions 60, 125 and 250 ml.

The reusable, electromechanical drive is identical for all models. If a different size is to be installed after discharge then it is only necessary to change the relevant lubricant cartridge and the correct, reusable top. All the parts, including the sensor cable, are available separately. This makes the G-LUBE VIB flexible and cost-effective to use. The reusability makes the device particularly environmentally friendly.

### Benefit from the G-LUBE VIB advantages

- Vibration sensor allows optimal lubrication
- Self-sufficient operation with battery operation
- One drive for all sizes
- Countdown of remaining duration on the display
- Numerous detailed status messages via display and LED

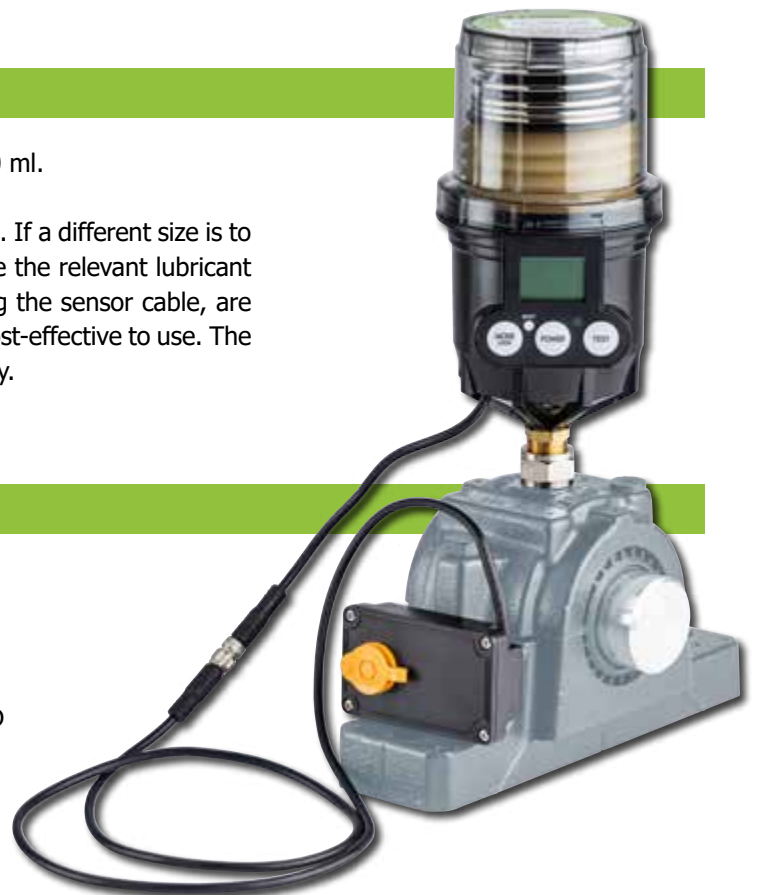

## Design

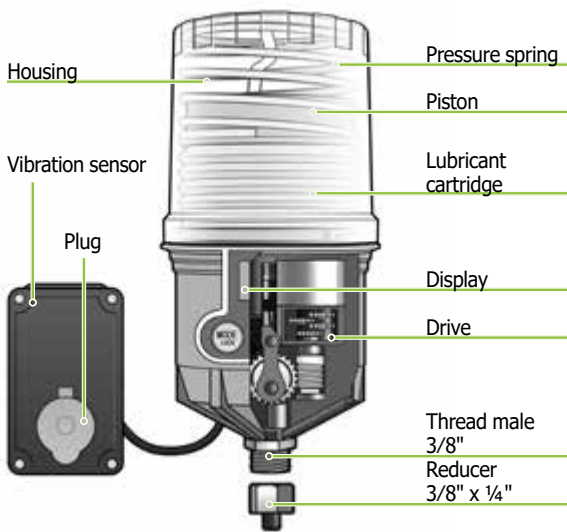

## Technical data

Model	GL-VIB-60	GL-VIB-125	GL-VIB-250
Drive	electromechanical (reusable)		
Operating pressure	max. 30 bar (435 psi)		
Distribution period	1-12 months		
Lubricant volume	60 ml	125 ml	250 ml
Lubricating medium	greases up to NLGI 2		
Operating temperature	Al battery: +5 °C to +60 °C Li battery: -20 °C to +60 °C		
Working voltage	4.5 V (Al or Li battery)		
Weight (without cartridge)	~ 732 g	~ 745 g	~ 810 g
Dimensions (height x Ø)	182 x 91 mm		208 x 91 mm
Performance monitoring	display & LED		
Distributor possible	✓*		

\*If a distributor is connected, the GL-BAT-L lithium battery is required.

## Detailed status reports

The display with its integrated LEDs offers very detailed status reports.

Particularly practical: a countdown of the remaining duration can be read on the display at all times during operation. The number of days since the last lubrication is also shown.

Error messages such as for an empty cartridge or low battery power can also be seen from far away in the form of flashing LEDs.



G-LUBE VIB ensures ideal lubrication in discontinuous operation by individual adjustment of the sensor. For an indirect installation we recommend our wide range of accessories (from page 24).



# LUB-S



## LUB-S - monitored lubrication of minimum volume

LUB-S can be used as single point lubricator or (by means of splitters or progressive distributors) as multipoint lubricator. Due to its extremely compact pump unit and its low weight it especially suits applications with lacking space.

### Models



Two types of LUB-S are available:

**LUB-S-B** runs with a 4.5 V battery and operates at up to 35 bar (508 psi). At low temperatures and/or with high back pressure we recommend using the more powerful lithium battery instead.

**LUB-S-V** uses 24 VDC and can be connected to PLC optionally. Its higher delivery pressure of up to 50 bar (725 psi) enables even more possible applications. Besides a 125 ml cartridge, a 250 ml cartridge can be screwed on anytime.

The built-in display allows you to keep track of all functions.

### Advances through innovation

LUB-S unites up to 3 operating modes in one device and offers maximum flexibility:

- **Hour mode:** setting the number of hours for the lubrication cycles
- **Discharge time mode:** setting the time in months until the cartridge is empty
- **Pulse mode:** LUB-S-V can be integrated into an external control system (PLC) and then commanded and controlled using this.

Thus LUB-S can be used flexibly and can be adapted to modified framework conditions at any time.



### Benefit from the LUB-S advantages

- Battery operation or with 24 VDC
- Up to 10x higher feed pressure than with gas-operated lubricant dispensers
- Compact dimensions
- Easy to operate
- Fault / empty reporting
- Suitable for splitters / progressive distributors (LUB-S-V)
- Connection to PLC possible (LUB-S-V)
- Up to 3 operating modes



## Design



## Technical data

Model	LUB-S-B	LUB-S-V
Drive	electromechanical (reusable)	
Operating pressure	max. 35 bar (508 psi)	max. 50 bar (725 psi)
Distribution period	1-24 months time mode	1-24 months time mode or pulse control
Lubricant volume	125 ml	125 or 250 ml
Lubricating medium	oils and greases up to NLGI 2	
Operating temperature	Al battery: +15 °C to +60 °C Li battery: -15 °C to +60 °C	-15 °C to +60 °C
Working voltage	4.5 V	24 VDC
Weight empty	~ 433 g	~ 422 g
Dimensions (height x Ø)	152 x 83 mm	
Performance monitoring	display & LED	
Distributor possible	-	✓

## LUB-S-V - multiple point lubrication



Thanks to its performance the LUB-S-V can also be used in combination with splitters or progressive distributors. This makes it possible to supply up to 10 lubrication points with one device.

All accessories such as fixing bracket, hose and distributors are available individually or in a practical set (see p. 38). Progressive distributors with circulation monitoring are also available and can be integrated into the monitoring. This gives you an overview of all the functions at all times.



**Multiple point lubrication**  
**Up to 10 lubrication points with**  
**progressive distributor**



# LUBRICUS



## Lubricus - the adaptive and compact lubrication system

Lubricus offers a new portal to the world of automatic lubrication. With the highly versatile Lubricus lubrication system, both single lubrication points and a whole group of varied points can be provided with lubricant continuously over a long period of time.

### Flexible lubrication

Lubricus is an extremely compact lubrication unit for oils and greases up to NLGI class 2. The lubrication system works either autonomously with a battery back or using an external voltage supply (24 VDC). The lubricant cartridge – optionally with 250 or 400 ml content – is simply screwed to the drive unit.

Lubricus is suitable for the simple and reliable supply of lubrication to bearings, linear guides, chains and open tooth systems, for which special lubricating pinions and lubricating gearwheels are available.

Due to the compact dimensions, Lubricus is optimally suited for upgrades or retrofitting. The large variety of models enable an individually optimized lubrication solution for almost every application.

### Benefit from the Lubricus advantages

- Delivery pressure up to 70 bar (1015 psi)
- Connection to machinery controls possible
- Distribution period 1–36 months or pause time
- Optical warning in the case of malfunction (LED)
- Operating temperature -15 °C to +70 °C
- Fault/empty reporting
- Temperature-independent feed rate
- Oils and greases up to NLGI cl. 2
- Special fillings available

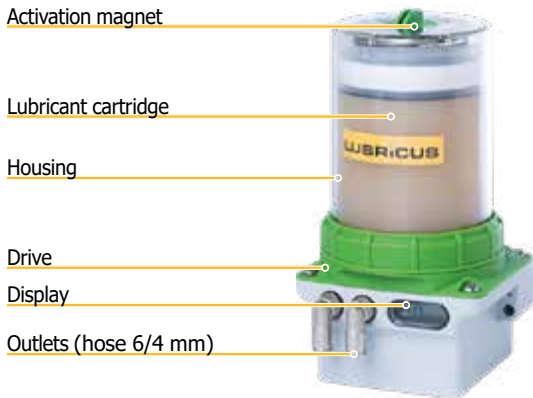

**Design**

**Technical data**

Model	Lubricus 250 ml	Lubricus 400 ml
Drive	electromechanical (reusable)	
Operating pressure	max. 70 bar (1015 psi)	
Distribution period	1 - 36 months / pause time	
Lubricant volume	250 ml	400 ml
Lubricating medium	oils and greases up to NLGI 2	
Operating temperature	-15 °C to +70 °C	
Working voltage	Li battery or 24 VDC	
Weight empty	1061 - 1524 g	
Dimensions (WxHxD)	112 x 165 x 94 mm	112 x 196 x 94 mm
Performance monitoring	green/red LED	
Distributor possible	✓	

**High flexibility through a wide range of models**

Dependent upon the version, Lubricus comes with up to four outlets and is thus optimally suitable with multiple lubrication.



	LUBRICUS B	LUBRICUS V	LUBRICUS C	LUBRICUS D
<b>Number of outlets</b>	1, 2	1, 2	1, 2, 3, 4	1, 2, 3, 4
<b>Display on the device</b>	yes	yes	no	no
<b>Working voltage</b>	battery	24 V	24 V	24 V
<b>Distribution period</b>	1-36 months or pause time	1-36 months or pause time <i>(intermittent operation possible)</i>	pause time <i>(individually adjustable)</i>	pause time <i>(individually adjustable)</i>
<b>Control</b>	time mode	time mode pulse control	time mode	pulse control
<b>Operation</b>	directly at the device	directly at the device	Lubricus Controller required	control using PLC



## Lubricus B - independent thanks to battery power



The battery-operated variant of the Lubricus lubrication system is always used when an autarkic operation is desired or necessary. The highly-efficient battery pack can optionally be set to empty the lubricant cartridge over a period of 1–36 months (or pause time).

- 1 or 2 outlets
- Lubricant volume 250 or 400 ml
- Supply pressure 70 bar (1015 psi)
- LCD display with LED
- "Quick-Check" (back-pressure readings)
- 1 to 36 months / pause time



**250 ml  
version  
available**



## Lubricus V - take a break



The 24 V variant of the Lubricus lubrication system is always the right choice when an external power supply can be attached simply. LUB-V's strengths become particularly apparent during discontinuous operation.

- 1 or 2 outlets, 70 bar
- Lubricant volume 250 or 400 ml
- Supply pressure 70 bar (1015 psi)
- LCD display with LED
- "Quick-Check" (back-pressure readings)
- Error readouts possible
- 1 to 36 months / pause time / pulse control



**250 ml  
version  
available**



## Lubricus D - pulse control



Lubricus D is designed for external control and 24 VDC voltage supply. The feed pump in Lubricus D feeds the lubricant to the outlets in accordance with the control of the pump openings using PLC.

- 1, 2, 3 or 4 outlets
- Lubricant volume 250 or 400 ml
- Supply pressure 70 bar (1015 psi)
- Flexible, individual volume assignment
- Feedback to the connected unit
- Exact control and lubricant dosing



**250 ml  
version  
available**





## Lubricus C - outsourced monitoring

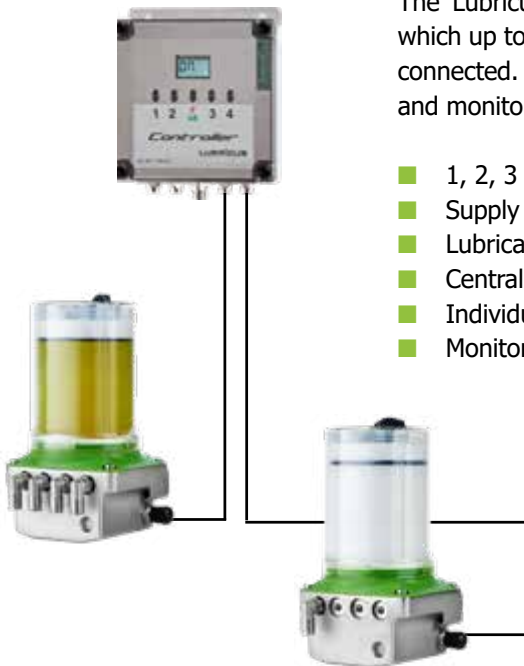

The Lubricus Controller is used for external monitoring of Lubricus, to which up to four Lubricus lubrication systems (4 outlets each = 16) can be connected. The connected lubricating devices can be individually controlled and monitored using the Lubricus Controller.

- 1, 2, 3 or 4 outlets
- Supply pressure 70 bar (1015 psi)
- Lubricating units are attached close to the actual lubricating points
- Central monitoring is possible (e.g. PLC)
- Individual supply volumes possible
- Monitoring of up to 16 lubrication points



## Lubricus C - installation example



The Lubricus Controller monitors and controls four Lubricus devices, which in turn supply a varying number of lubricating points. The paths that the lubricant has to travel along the lines can be kept simple and short; nevertheless central monitoring takes place via the Lubricus Controller. Installation and maintenance requirements are sustainably reduced.



# LUB-Z



## LUB-Z - flexible, automatic provision of up to 8 lubrication points

The powerful LUB-Z allows maximal flexibility.

The dual control system is either carried out using an integrated time or, externally, using a PLC. This makes the lubrication system suitable for both the lubrication with minimal quantities and the provision of lubrication points with high lubricant requirements - independently of whether the machine being lubricated is operated continuously or discontinuously.

### Wide range of applications

LUB-Z is designed for a 24 VDC power supply. Supply pressure is up to 70 bar (1015 psi). The lubrication system can work either in **time mode** or in **pulse mode** (PLC).

In time mode, the internal controls monitor both the amount of lubricant and the time intervals between lubrications.

In pulse mode, the desired lubrication intervals are performed by programming the PLC.

Each pump body can be controlled separately, independently of the mode that is selected, which enables individual output volumes for each. Outlet volumes can be set from 0.16 to 15.4 ml.

### Benefit from the LUB-Z advantages

- Simple assembly - no complex piping
- Dual control via integrated timer or externally via PLC
- Powerful with up to 70 bar (1015 psi) delivery pressure
- Low-impact lubricant conveyance
- Detailed monitoring of up to 10 lube points
- All pumps provide individually distributable volume
- Intuitive programming via LCD display
- Settings can be modified at any time
- Integrated back pressure monitoring



## Design

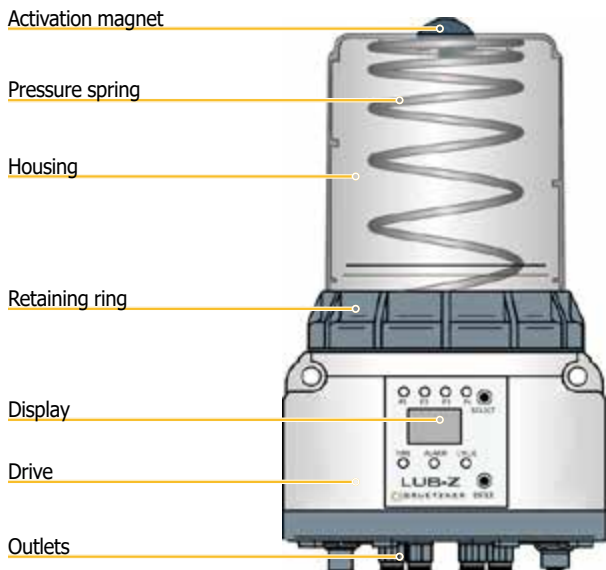

## Technical data

Model	LUB-Z	LUB-Z-OIL
Drive	electromechanical (reusable)	
Operating pressure	max. 70 bar (1015 psi)	
Distribution period	individually adjustable	
Lubricant volume	800 ml	1000 ml
Lubricating medium	greases up to NLGI 2	oils
Operating temperature	-20 °C to +70 °C	
Working voltage	24 VDC	
Weight empty	~ 3000 g	
Dimensions (WxHxD)	158 x 273 x 152 mm	
Performance monitoring	display & LED	
Distributor possible	✓	

## Models



The lubrication system is available in four different versions. They differ in the number of pump bodies/outlets and the lubricant used.

- 4 or 8 outlets
- Operation with grease: using a cartridge, volume 800 ml
- Operation with oil: no cartridge, volume 1,000 ml



**Proven a thousand times over**  
**No experiments! The installed pump technology has been tested in every sector and has shown itself to be reliable over many years and applications.**



## Applications

Automotive industry



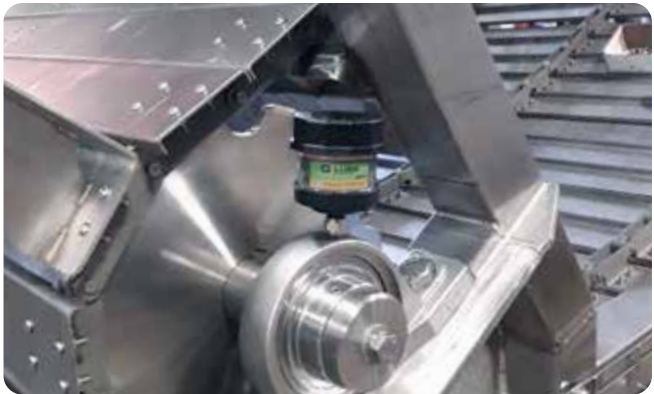

Food industry



**Electric motors**



**Sewage works**



**Mining industry**



**Energy industry**

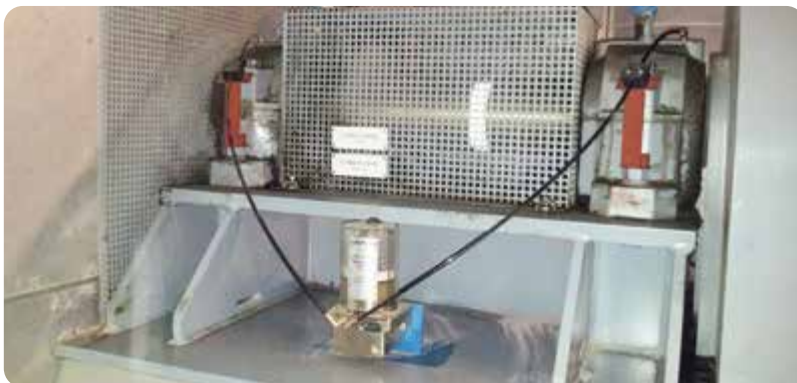

**Mechanical engineering**



Printing press



Plastics processing



**Other branches**

Steel treatment



Brick making



Paper conversion

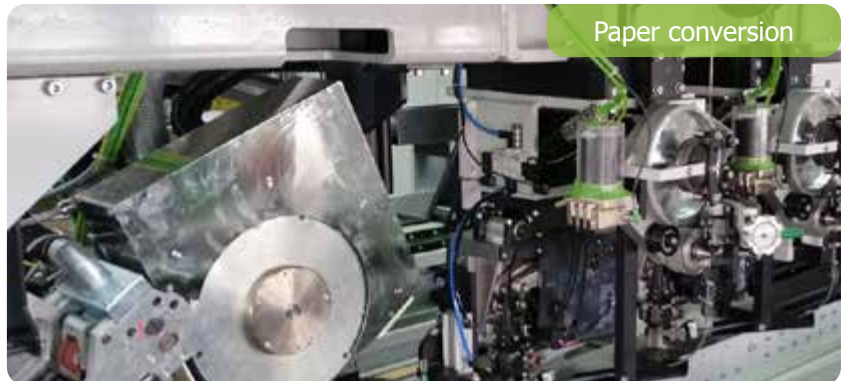









# Gruetzner standard lubricants





## Standard lubricants – greases

Grease  No.  	Base oil	NLGI class	Thickener	Operating temperature	Viscosity at +40 °C	Applications				
						Roller bearings 	Plain bearings 	Linear guides 	Gears/ toothed racks 	Spindles 
<b>01</b> Multipurpose grease Water-resistant, long-term grease	mineral	2	Li-Ca	-30 °C to +130 °C	220	✓	✓	●	●	✓
<b>02</b> Multipurpose grease with MoS <sub>2</sub>	mineral	2	Li	-30 °C to +130 °C	195	●	✓	—	✓	—
<b>03</b> High temperature grease up to 160 °C <i>(with continuous relubrication 220 °C)</i>	Ester/SHC	1	PHS	-40 °C to +160 °C <i>(+220 °C)</i>	150	✓	✓	—	—	●
<b>04</b> High temperature grease up to 180 °C	mineral	1	Calcium sulfonate complex	-30 °C to +180 °C	220	✓	●	—	●	●
<b>05</b> High pressure grease	mineral	2	Calcium sulfonate complex	-30 °C to +150 °C	410	✓	✓	—	●	—
<b>06</b> Water-resistant fluid grease	mineral	0	Ca complex	-30 °C to +140 °C	120	✓	✓	✓	✓	●
<b>07</b> Special grease for gear drives	mineral	0	Li-Ca	-30 °C to +150 °C	800	—	✓	—	✓	●
<b>09</b> Special biodegradable grease	Ester	2	Li-Ca	-40 °C to +120 °C	130	✓	✓	●	●	—
<b>10</b> Special grease for the food, beverage and pharmaceuticals industry 	mineral	1	Al special	-20 °C to +160 °C	460	✓	✓	●	✓	●

✓ compatible    ● testing required    — incompatible



## Standard lubricants – oils

Oil	Base oil	Operating temperature	Viscosity at +40 °C	Applications					
				Roller bearings	Plain bearings	Linear guides	Gears/toothed racks	Spindles	Chains
<b>No.</b> 									
<b>14</b> Multipurpose oil	mineral	-10 °C to +90 °C	68	–	●	●	–	–	✓
<b>15</b> High-temperature chain oil	Ester/SHC	-20 °C to +300 °C	270	–	●	●	–	–	✓
<b>64</b> Special biodegradable oil	synthetic	-20 °C to +120 °C	145	–	●	●	–	–	✓
<b>70</b> Special oil for the food, beverage and pharmaceuticals industry (NSF-H1)	 synthetic	-30 °C to +140 °C	96	–	●	●	–	–	✓
<b>77</b> Medicinal white oil	 mineral	0 °C to +60 °C	70	–	●	●	–	–	✓

✓ compatible   ● testing required   – incompatible

## Self-filling & supplied lubricants

Our tested standard lubricants meet the highest standards and our range ensures that there is a standard type for almost every application. We also offer many of our products empty so that you can fill them with your own lubricant. Filling the lubricant yourself is easy and allows observation of certain stipulations such as periods of warranty and guarantee or safety regulations. Of course, we will be glad to fill the lubricant dispenser with your choice of lubricant – **simply contact us!**

Individual							NLGI class	Thickener
<b>00</b> Empty, for self-filling	✓	✓	✓	–	–	–	max. 2	any
<b>X</b> Filled with supplied lubricant	✓	✓	✓	✓	✓	✓	max. 2	any



## Accessories

On the following pages you can find various accessory components that could be very helpful for the installation of our lubrication systems. Depending on whether the lubrication system is to be attached directly to the lubrication point or indirectly installed to dispense via a hose – here you will find the right connectors for easily and correctly installing our lubrication systems.

Please note that some connectors are only suitable for specific lubricant dispensers.







### Connectors







Art. no.	Bent connections & other connectors	Material							Fig. no.
<b>SAT1001</b>	Bent connection 45° G $\frac{1}{4}$ " x G $\frac{1}{4}$ "	Malleable cast iron, galvanized	✓	✓	✓	✓	✓	✓	1
<b>SAT1001E</b>	Bent connection 45° G $\frac{1}{4}$ " x G $\frac{1}{4}$ "	Stainless steel/V4A	✓	✓	✓	✓	✓	✓	2
<b>SAT1002</b>	Bent connection 90° G $\frac{1}{4}$ " x G $\frac{1}{4}$ "	Malleable cast iron, galvanized	✓	✓	✓	✓	✓	✓	3
<b>SAT1002E</b>	Bent connection 90° G $\frac{1}{4}$ " x G $\frac{1}{4}$ "	Stainless steel/V4A	✓	✓	✓	✓	✓	✓	4
<b>SAT1002MS</b>	Bent connection 90° R $\frac{1}{4}$ " x R $\frac{1}{4}$ "	Brass nickel-plated	✓	✓	✓	✓	✓	✓	5
<b>SAT1004</b>	Bent connection 90°, rotatable, R $\frac{1}{4}$ "	Brass	✓	✓	✓	✓	✓	✓	6
<b>SAT3020</b>	Double socket G $\frac{1}{4}$ " x G $\frac{1}{4}$ "	Brass nickel-plated	✓	✓	✓	✓	✓	✓	7
<b>SAT1093</b>	Double socket G $\frac{1}{4}$ " x G $\frac{1}{4}$ "	Brass nickel-plated	✓	✓	✓	✓	✓	✓	8
<b>SAT1050</b>	Y-manifold	Brass nickel-plated	✓	✓	✓	✓	✓	✓	9
<b>SAT3012</b>	Refill-nipple for filling Sololube	Brass nickel-plated	-	✓	-	-	-	-	10
<b>LAT1099</b>	Thread adapter M16x1.5 x G $\frac{1}{4}$ "	Stainless steel	-	-	-	-	✓	-	11







  

Figures										
										
1	2	3	4	5	6	7	8	9	10	11

Art. no.	Reducers	Material							Fig. no.	
<b>SAT1020</b>	Reducer G $\frac{1}{4}$ " x G $\frac{1}{8}$ "	Brass nickel-plated	✓	✓	✓	✓	✓	✓	1	
<b>SAT1021</b>	Reducer G $\frac{1}{4}$ " x G $\frac{1}{4}$ "	Brass nickel-plated	✓	✓	✓	✓	✓	✓	2	
<b>SAT1022</b>	Reducer G $\frac{1}{4}$ " x M6	Brass nickel-plated	✓	✓	✓	✓	✓	✓	3	
<b>SAT1023</b>	Reducer G $\frac{1}{4}$ " x M8	Brass nickel-plated	✓	✓	✓	✓	✓	✓	4	
<b>SAT1024</b>	Reducer G $\frac{1}{4}$ " x M8x1	Brass nickel-plated	✓	✓	✓	✓	✓	✓	5	
<b>SAT1025</b>	Reducer G $\frac{1}{4}$ " x M10	Brass nickel-plated	✓	✓	✓	✓	✓	✓	6	
<b>SAT1026</b>	Reducer G $\frac{1}{4}$ " x M10x1	Brass nickel-plated	✓	✓	✓	✓	✓	✓	7	
<b>SAT1027</b>	Reducer G $\frac{1}{4}$ " x M12	Brass nickel-plated	✓	✓	✓	✓	✓	✓	8	
<b>SAT1028</b>	Reducer G $\frac{1}{4}$ " x M12x1.5	Brass nickel-plated	✓	✓	✓	✓	✓	✓	9	
<b>SAT1010</b>	Connection nipple straight G $\frac{1}{4}$ " x G $\frac{3}{8}$ "	Brass nickel-plated	✓	✓	✓	✓	✓	✓	10	
<b>SAT1011</b>	Connection nipple straight G $\frac{1}{4}$ " x G $\frac{1}{2}$ "	Brass nickel-plated	✓	✓	✓	✓	✓	✓	11	
<b>Figures</b>										
										







Art. no.	Extensions & screwed connections (dimensions including external thread)	Material							Fig. no.	
<b>SAT1040</b>	Extension 35 mm G $\frac{1}{4}$ " x G $\frac{1}{4}$ "	Brass nickel-plated	✓	✓	✓	✓	✓	✓	1	
<b>SAT1041</b>	Extension 50 mm G $\frac{1}{4}$ " x G $\frac{1}{4}$ "	Brass nickel-plated	✓	✓	✓	✓	✓	✓	2	
<b>SAT1042</b>	Extension 75 mm G $\frac{1}{4}$ " x G $\frac{1}{4}$ "	Galvanized steel	✓	✓	✓	✓	✓	✓	3	
<b>SAT1043</b>	Extension 115 mm G $\frac{1}{4}$ " x G $\frac{1}{4}$ "	Galvanized steel	✓	✓	✓	✓	✓	✓	4	
<b>SAT1045</b>	Screwed connection 25 mm, incl. 1 nut G $\frac{1}{4}$ "	Brass nickel-plated	✓	✓	✓	✓	✓	✓	5	
<b>SAT1046</b>	Screwed connection 60 mm, incl. 2 nuts G $\frac{1}{4}$ "	Brass nickel-plated	✓	✓	✓	✓	✓	✓	6	
<b>Figures</b>										
										

Art. no. straight	Art. no. angled	Hose adapters (for hose Ø 8 mm)	Material							Fig. no.
<b>SAT1060</b>	<b>SAT1060G</b>	Hose adapter R $\frac{1}{4}$ "	Brass nickel-plated	✓	✓	✓	-	-	-	1
<b>SAT1070</b>	<b>SAT7076G-8</b>	Hose adapter R $\frac{1}{8}$ "	Plastic, brass nickel-plated	✓	✓	✓	-	-	-	2
<b>SAT7084-8</b>	<b>SAT7084G-8</b>	Hose adapter M6	Brass nickel-plated	✓	✓	✓	-	-	-	3
<b>SAT7086-8</b>	<b>SAT7086G-8</b>	Hose adapter M8x1	Brass nickel-plated	✓	✓	✓	-	-	-	4

Art. no. straight	Art. no. angled	Hose adapters (for hose Ø 8 mm)	Material							Fig. no.
SAT7087-8	SAT7087G-8	Hose adapter M10x1	Brass nickel-plated	✓	✓	✓	-	-	-	5
SAT1071	SAT1071G	Hose adapter G¼"	Brass nickel-plated	✓	✓	✓	-	-	-	6
SAT1072	-	Hose adapter R3/8"	Brass nickel-plated	✓	✓	✓	-	-	-	7







**Figures**

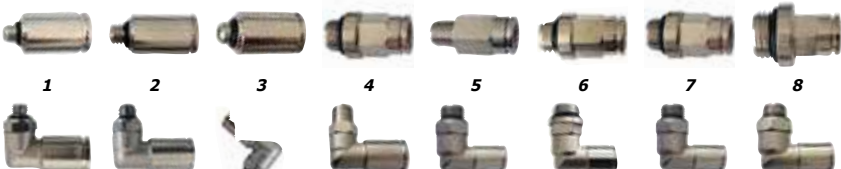

Art. no. straight	Art. no. angled	Hose adapters (for hose Ø 6 mm)	Material							Fig. no.
LAT7097	LAT7097G	Hose adapter M5	Brass nickel-plated	-	-	-	✓	✓	✓	1
LAT7084	LAT7084G	Hose adapter M6	Brass nickel-plated	-	-	-	✓	✓	✓	2
LAT7085	LAT7085G	Hose adapter M6 x 0.75	Brass nickel-plated	-	-	-	✓	✓	✓	3
LAT7089	LAT7089G	Hose adapter M8	Brass nickel-plated	-	-	-	✓	✓	✓	4
LAT7086	LAT7086G	Hose adapter M8 x 1	Brass nickel-plated	-	-	-	✓	✓	✓	5
LAT7087	LAT7087G	Hose adapter M10 x 1	Brass nickel-plated	-	-	-	✓	✓	✓	6
LAT7076	LAT7076G	Hose adapter G1/8"	Brass nickel-plated	-	-	-	✓	✓	✓	7
LAT7079	LAT7079G	Hose adapter G¼"	Brass nickel-plated	-	-	-	✓	✓	✓	8

**Figures**













Art. no. straight	Art. no. angled	Hose connectors (hose to hose)	Material							Fig. no.
SAT1067	SAT1067G	Hose connector 8 mm to 8 mm	Brass nickel-plated	-	-	-	✓	✓	✓	1
LAT7100	LAT7100G	Hose connector 6 mm to 6 mm	Brass nickel-plated	-	-	-	✓	✓	✓	2
LAT7101	-	Hose connector 6 mm to 8 mm	Brass nickel-plated	-	-	-	✓	✓	✓	3
LAT1050-6	-	Hose connector 6 mm to 6 mm Y shape	Brass nickel-plated	-	-	-	✓	✓	✓	4
LAT1050-8	-	Hose connector 8 mm to 8 mm Y shape	Brass nickel-plated	-	-	-	✓	✓	✓	5

**Figures**

















## Hoses







Art. no.	Hose filling adapters & hoses	Material								Fig. no.
<b>SAT2000</b>	Hose Ø 8/6 mm, per meter	PU	✓	✓	✓	-	-	-	-	1
<b>LAT8002</b>	High pressure hose Ø 6/4 mm, per meter	PA12	-	-	-	✓	✓	✓	-	2
<b>SAT3017</b>	Hose filling adapter for hose 8 mm	Brass nickel-plated	✓	✓	✓	-	-	-	-	3
<b>LAT3017</b>	Hose filling adapter for hose 6 mm	Brass nickel-plated	-	-	-	✓	✓	✓	-	4
<b>Figures</b>										
   										



We fill all hoses with lubricant on request (according to scheme page 22/23 or individually customized).

## Batteries & 24 V adapters

Art. no.	Batteries & 24 V adapters								Fig. no.
<b>SOL-BAT</b>	Sololube battery, 6.0 V, suitable for all Sololube models	-	✓	-	-	-	-	-	1
<b>GL-BAT-A</b>	Al battery, 4.5 V incl. case for GL-VIB	-	-	-	✓	-	-	-	2
<b>GL-BAT-L</b>	Li battery, 4.5 V incl. case for GL-VIB	-	-	-	✓	-	-	-	3
<b>LAT-BAT-SA</b>	Al battery, 4.5 V for LUB-S-B	-	-	-	-	✓	-	-	4
<b>LAT-BAT-SL</b>	Li battery, 4.5 V for LUB-S-B	-	-	-	-	✓	-	-	5
<b>LAT-BAT-L</b>	Li high performance battery, 3.0 V for Lubricus B (generation I, until 2019)	-	-	-	-	-	-	✓	6
<b>LAT-BAT-4</b>	Li high performance battery, 6.0 V for Lubricus B (generation II, from 2020)	-	-	-	-	-	-	✓	7
<b>SOL-24 V-1</b>	Sololube 24 V adapter for external power supply (models: Xtra60, Xtra150)	-	✓	-	-	-	-	-	8
<b>SOL-24 V-2</b>	Sololube 24 V adapter for external power supply (model: Xtra250)	-	✓	-	-	-	-	-	8
<b>Figures</b>									
       									

## Brackets

Art. no.	Brackets	Material								Fig. no.
<b>GAT2800</b>	Universal mounting bracket	Stainless steel	✓	✓	✓	✓	✓	-	-	1
<b>GAT2010</b>	Holding clamp for G-LUBE	Plastic	✓	-	-	-	-	-	-	2
<b>GAT2010M</b>	Magnetic holding clamp for G-LUBE	Plastic	✓	-	-	-	-	-	-	3

Art. no.	Brackets	Material							Fig. no.
<b>GAT2008</b>	Steel holding clamp for G-LUBE	Galvanized steel, rubber	✓	-	-	-	-	-	4
<b>SAT1051</b>	Support adapter for G-LUBE G¼" x G¼"	Steel	✓	-	-	-	-	-	5
<b>SAT1052</b>	Support adapter for G-LUBE G¼" x G¼"	Stainless steel	✓	-	-	-	-	-	6
<b>SAT8020</b>	Mounting bracket for Sololube	Stainless steel	-	✓	-	-	-	-	7
<b>SAT7800</b>	Universal mounting bracket	Stainless steel	✓	✓	✓	✓	✓	-	8
<b>LAT8802</b>	Mounting bracket for LUB-S	Stainless steel	-	-	-	-	✓	-	9
<b>LAT8803</b>	Mounting bracket for LUB-S	Stainless steel	-	-	-	-	✓	-	10
<b>LAT8804</b>	Mounting bracket for LUB-S + progressive distributor	Stainless steel	-	-	-	-	✓	-	11
<b>LAT8801</b>	Mounting bracket for Lubricus	Coated zinc	-	-	-	-	-	✓	12







#### Figures



### Connection cables

For 12x1 connectors (4-pin, A-coded), connection cables are available in various lengths. The connection cable with LED angled connectors is particularly popular, as its LEDs also provide visual information about the device's operating status. Perhaps you need a special length? **Contact us!**



Art. no.	Connection cables							Fig. no.
<b>LAT-WI-0-5</b>	Connection cable, M12x1, open end, 5 m	-	-	-	-	✓	✓	1
<b>LAT-WI-0-10</b>	Connection cable, M12x1, open end, 10 m	-	-	-	-	✓	✓	1
<b>LAT-WI-8-5</b>	Connection cable, M12x1/M8x1, 5 m (connecting Lubricus C to Lubricus Controller)	-	-	-	-	-	✓	2
<b>LAT-WI-8-10</b>	Connection cable, M12x1/M8x1, 10 m (connecting Lubricus C to Lubricus Controller)	-	-	-	-	-	✓	2
<b>LAT-WI-ST-LED-5</b>	Connection cable, M12x1, open end, 5 m with LED angled socket	-	-	-	-	✓	✓	3
<b>LAT-WI-ST-LED-10</b>	Connection cable, M12x1, open end, 10 m with LED angled socket	-	-	-	-	✓	✓	3
<b>LAT 8080</b>	Power supply/transformer 230 VAC / 24 VDC incl. M12x1 connector (EU version)	-	-	-	-	✓	✓	4

#### Figures



## Distributors

### Splitters

Splitters portion the lubricant quantity evenly across the outlets and are suitable for oils and greases up to NLGI class 2. The amount of lubricant yielded by the lubrication system can be split into two, three or four parts and then transported to the lubrication point.



Art. no.	Splitter (divider) for grease OR oil	Material							Fig. no.
<b>LAT-Split-2</b>	Splitter 1:2 for grease	Aluminium	-	-	-	✓*	✓	✓	1
<b>LAT-Split-3</b>	Splitter 1:3 for grease	Aluminium	-	-	-	✓*	✓	✓	2
<b>LAT-Split-4</b>	Splitter 1:4 for greaset	Aluminium	-	-	-	✓*	✓	✓	3
<b>LAT-Split-20</b>	Splitter 1:2 for oil >ISO VG100	Aluminium	-	-	-	-	✓	✓	1
<b>LAT-Split-30</b>	Splitter 1:3 for oil >ISO VG100	Aluminium	-	-	-	-	✓	✓	2
<b>LAT-Split-40</b>	Splitter 1:4 for oil >ISO VG100	Aluminium	-	-	-	-	✓	✓	3
<b>LAT-Split-20-S</b>	Splitter 1:2 for oil <ISO VG100	Aluminium	-	-	-	-	✓	✓	1
<b>LAT-Split-30-S</b>	Splitter 1:3 for oil <ISO VG100	Aluminium	-	-	-	-	✓	✓	2
<b>LAT-Split-40-S</b>	Splitter 1:4 for oil <ISO VG100	Aluminium	-	-	-	-	✓	✓	3

#### Figures









\* If a distributor is connected, the GL-BAT-L lithium battery is required.

### Progressive distributors

The progressive distributors have a variable modular design. Lubricant is "forcibly" progressively distributed via a follow-up piston. In this way, the amount of lubricant yielded by the lubrication system can be split equally. Progressive distributors can be used for oils and greases up to NLGI class 2.

All progressive distributors are also offered as part of a LUB-S-V set (see page 38).



Art. no.	Progressive distributors (PRV) for grease and oil		Material							Fig. no.
<b>LAT-PRV-2</b>	PRV 2 outlets	<b>LAT-PRV-3</b>	PRV 3 outlets	Aluminium	-	-	-	✓*	✓	1 2
<b>LAT-PRV-4</b>	PRV 4 outlets	<b>LAT-PRV-5</b>	PRV 5 outlets	Aluminium	-	-	-	✓*	✓	3 4
<b>LAT-PRV-6</b>	PRV 6 outlets	<b>LAT-PRV-7</b>	PRV 7 outlets	Aluminium	-	-	-	✓*	✓	5 6
<b>LAT-PRV-8</b>	PRV 8 outlets	<b>LAT-PRV-9</b>	PRV 9 outlets	Aluminium	-	-	-	✓*	✓	7 8
<b>LAT-PRV-10</b>	PRV 10 outlets			Aluminium	-	-	-	✓*	✓	9

#### Figures









\* GL-VIB is only suitable for operation with grease. If a distributor is connected, the GL-BAT-L lithium battery is required.

### Monitored progressive distributors

This extended version of a progressive distributor enables remote operation monitoring. A signal is transferred to a sensor and an evaluable return signal is generated at each piston movement. LEDs on the connector's housing then indicate the switching status of the progressive distributor.



Art. no.	Monitored progressive distributors (PRV-M) for grease and oil			Material					LUB-SV		Fig. no.
	PRV-M 2 outlets	LAT-PRV-3-M	PRV-M 3 outlets								
<b>LAT-PRV-2-M</b>	PRV-M 2 outlets	<b>LAT-PRV-3-M</b>	PRV-M 3 outlets	Aluminium	-	-	-	✓*	✓	✓	1 2
<b>LAT-PRV-4-M</b>	PRV-M 4 outlets	<b>LAT-PRV-5-M</b>	PRV-M 5 outlets	Aluminium	-	-	-	✓*	✓	✓	3 4
<b>LAT-PRV-6-M</b>	PRV-M 6 outlets	<b>LAT-PRV-7-M</b>	PRV-M 7 outlets	Aluminium	-	-	-	✓*	✓	✓	5 6
<b>LAT-PRV-8-M</b>	PRV-M 8 outlets	<b>LAT-PRV-9-M</b>	PRV-M 9 outlets	Aluminium	-	-	-	✓*	✓	✓	7 8
<b>LAT-PRV-10-M</b>	PRV-M 10 outlets			Aluminium	-	-	-	✓*	✓	✓	9
<b>Figures</b>											
											

\* GL-VIB is only suitable for operation with grease. If a distributor is connected, the GL-BAT-L lithium battery is required.



# Lubrication gears & chain lubrication pinions

## Lubrication gears & axles

### Lubrication gears

The lubricant passes through the axle and appropriate holes in the foam material. With just a low contact pressure, the stored lubricant is released again. The open-cell PU foam used stores the lubricant and releases it again in very small doses. In this way, over-lubrication is effectively prevented, as is possible wear caused by a lack of lubrication.

Operating temperature: -30 °C to +150 °C

Lubrication gears can be combined with all Gruetzner lubricant dispensers.



Gear tooth system				Module	Width
straight	sloping right rising	sloping left rising			
Art. no.			Lubrication gears		
LAT-SZ-G-2	LAT-SZ-R-2	LAT-SZ-L-2	Lubrication gear module 2, incl. sleeve, without axis	02	20 mm
LAT-SZ-G-3	LAT-SZ-R-3	LAT-SZ-L-3	Lubrication gear module 3, incl. sleeve, without axis	03	30 mm
LAT-SZ-G-4	LAT-SZ-R-4	LAT-SZ-L-4	Lubrication gear module 4, incl. sleeve, without axis	04	40 mm
LAT-SZ-G-5	LAT-SZ-R-5	LAT-SZ-L-5	Lubrication gear module 5, incl. sleeve, without axis	05	50 mm
LAT-SZ-G-6	LAT-SZ-R-6	LAT-SZ-L-6	Lubrication gear module 6, incl. sleeve, without axis	06	60 mm
LAT-SZ-G-8	LAT-SZ-R-8	LAT-SZ-L-8	Lubrication gear module 8, incl. sleeve, without axis	08	80 mm
LAT-SZ-G-10	LAT-SZ-R-10	LAT-SZ-L-10	Lubrication gear module 10, incl. sleeve, without axis	10	100 mm

### Figures



straight

sloping right rising

sloping left rising

### Axles

Different fastening axles are available for the lubricating gearwheels. Dependent on the installation or supply of lubricant, right-angled or straight axles can be used.

Mounting options for the axles can be found on page 33.

Axles can be combined with all Gruetzner lubrication gears.



Straight axles				Angled axles			
Art. no.	Fixing of axle	Thread hollow axle	Width	Art. no.	Fixing of axle	Thread hollow axle	Width
LAT-A-2	M10	M6	20 mm	LAT-A-2G	M8	M10x1	20 mm
LAT-A-3	M10	M6	30 mm	LAT-A-3G	M8	M10x1	30 mm
LAT-A-4	M10	M6	40 mm	LAT-A-4G	M8	M10x1	40 mm
LAT-A-5	M16	M10x1	50 mm	LAT-A-5G	M8	M10x1	50 mm
LAT-A-6	M16	M10x1	60 mm	LAT-A-6G	M8	M10x1	60 mm
LAT-A-8	M16	M10x1	80 mm	LAT-A-8G	M8	M10x1	80 mm
LAT-A-10	M16	M10x1	100 mm	LAT-A-10G	M8	M10x1	100 mm

Figures

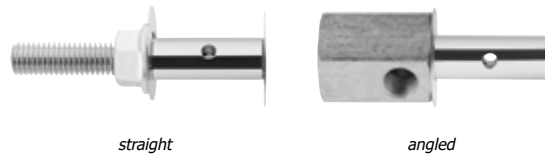

## Chain lubrication pinions

Besides lubricant brushes, chain lubrication pinions are a very reliable, clean alternative for lubricating chains. As with the lubricating of gearwheels, the lubricant passes through the axle and corresponding holes into the foam material, the pinion ensures quiet running.

Chain lubrication pinions can be combined with all Gruetzner lubricant dispensers. The open-cell PU foam rollers transfer the lubricant in a point-wise manner to the surfaces of the lugs of roller chains. The mechanical force to drive the rollers is ensured by a low-wear plastic pinion. Chain lubrication pinions are designed for use with oil and at an operating temperature between -30 °C and +60 °C. Special models suitable for larger temperature ranges are available on request.



Simplex		Duplex		Chain lubrication pinions with straight axle	Fixing of axle	Thread hollow axle
Art. no.	ISO no.	Art. no.	ISO no.			
LAT-KR-S-08	08 B-1	LAT-KR-D-08	08 B-2	Chain lubrication pinion with straight axle, ½" x 5/16"	M10	M6
LAT-KR-S-10	10 B-1	LAT-KR-D-10	10 B-2	Chain lubrication pinion with straight axle, 5/8" x 3/8"	M10	M6
LAT-KR-S-12	12 B-1	LAT-KR-D-12	12 B-2	Chain lubrication pinion with straight axle, ¾" x 7/16"	M10	M6
LAT-KR-S-16	16 B-1	LAT-KR-D-16	16 B-2	Chain lubrication pinion with straight axle, 1" x 17 mm	M10	M6
LAT-KR-S-20	20 B-1	LAT-KR-D-20	20 B-2	Chain lubrication pinion with straight axle, 1¼" x ¾"	M16	M10x1
LAT-KR-S-24	24 B-1	LAT-KR-D-24	24 B-2	Chain lubrication pinion with straight axle, 1½" x 1"	M16	M10x1
LAT-KR-S-32	32 B-1	LAT-KR-D-32	32 B-2	Chain lubrication pinion with straight axle, 2" x 1¼"	M16	M10x1

Figures



Simplex		Duplex		Chain lubrication pinions with angled axle	Fixing of axle	Thread hollow axle
Art. no.	ISO no.	Art. no.	ISO no.			
<b>LAT-KR-S-08G</b>	08 B-1	<b>LAT-KR-D-08G</b>	08 B-2	Chain lubrication pinion with angled axle, 1/2" x 5/16"	M8	M10x1
<b>LAT-KR-S-10G</b>	10 B-1	<b>LAT-KR-D-10G</b>	10 B-2	Chain lubrication pinion with angled axle, 5/8" x 3/8"	M8	M10x1
<b>LAT-KR-S-12G</b>	12 B-1	<b>LAT-KR-D-12G</b>	12 B-2	Chain lubrication pinion with angled axle, 3/4" x 7/16"	M8	M10x1
<b>LAT-KR-S-16G</b>	16 B-1	<b>LAT-KR-D-16G</b>	16 B-2	Chain lubrication pinion with angled axle, 1" x 17 mm	M8	M10x1
<b>LAT-KR-S-20G</b>	20 B-1	<b>LAT-KR-D-20G</b>	20 B-2	Chain lubrication pinion with angled axle, 1 1/4" x 3/4"	M8	M10x1
<b>LAT-KR-S-24G</b>	24 B-1	<b>LAT-KR-D-24G</b>	24 B-2	Chain lubrication pinion with angled axle, 1 1/2" x 1"	M8	M10x1
<b>LAT-KR-S-32G</b>	32 B-1	<b>LAT-KR-D-32G</b>	32 B-2	Chain lubrication pinion with angled axle, 2" x 1 1/4"	M8	M10x1

#### Figures



Simplex



Duplex

If you have a special application that is too complex for lubrication using standard chain lubrication pinions, you can use a special lubricating roll (see page 36).

### Mounting chain lubrication pinions & lubrication gears

#### Spring steel sheets with chain lubrication pinion

Spring steel sheets allow the chain lubrication pinions to be installed quickly and easily. A light preload ensures the continuous supply of lubricant; a further advantage of this type of installation is that the whole assembly can flexibly yield to fluctuations and vibrations. The spring steel sheet is available in both short and long versions and can be combined with an **angled axle**.



Spring steel sheets with chain lubrication pinion	Simplex		Duplex	
	Steel sheet short	Steel sheet long	Steel sheet short	Steel sheet long
Chain lubrication pinion 1/2" x 5/16"	✓	✓	✓	✓
Chain lubrication pinion 5/8" x 3/8"	✓	✓	✓	✓
Chain lubrication pinion 3/4" x 7/16"	✓	✓	✓	✓
Chain lubrication pinion 1" x 17 mm	✓	✓	✓	-
Chain lubrication pinion 1 1/4" x 3/4"	✓	-	-	-

#### Figures



Simplex with steel sheet short



Duplex with steel sheet long

### Tensioning elements

The tensioning element enables the setting of an optimum contact pressure. In addition, the sturdy construction ensures stability and so increases work safety during operation. The tensioning element can only be used with **straight axles** (deflection max. 50 mm, clamping force 350 N).



Art. no.	Tensioning elements	Material	Figures
LAT-SP-10	Tensioning element for axle M10	Steel	 <i>exemplary illustration</i>
LAT-SP-16	Tensioning element for axle M16	Steel	

### Flexible brackets

A flexible, springy bracket is a simple installation option for chain lubrication pinions or lubrication gears. Thanks to the spring built into the joint, the contact pressure can be individually adjusted, and at the same time the bracket can also cushion counter-movements. Depending upon the size of the axle used, the holes in the flexible bracket are either size M10 or M16. The bracket is available with the flexible joint on either the right or left side.



Art. no.	Flexible brackets	Material	Figures
LAT-FL-WI-L-10	Bracket left for axle M10	Steel	 <i>exemplary illustration            chain lubrication            pinion and hose screw            connection not included            in the scope of delivery</i>
LAT-FL-WI-R-10	Bracket right for axle M10	Steel	
LAT-FL-WI-L-16	Bracket left for axle M16	Steel	
LAT-FL-WI-R-16	Bracket right for axle M16	Steel	

## Brushes & rolls

### Lubricating rolls

For many applications, such as special chains or wheel flange lubrication, it is difficult to find a "one size fits all" solution. For cases such as these we offer lubricating rolls made from various materials that come in different widths and diameters. Special sizes with straight or angled axles are also possible – **simply contact us!**

Brushes can be combined with all Gruetzner lubricant dispensers.



Art. no.	Lubricating rolls	Diameter	Width	Fig. no.
<b>LAT-RO-30-45-FG</b>	PU lubricating roll, angled axle and spring steel	30 mm	45 mm	1
<b>LAT-RO-40-30-FG</b>	PU lubricating roll, angled axle and spring steel	40 mm	30 mm	1
<b>LAT-RO-70-50-A</b>	PU lubricating roll, straight axle	70 mm	50 mm	2
<b>LAT-RO-100-100-A</b>	PU lubricating roll, straight axle	100 mm	100 mm	2
<b>LAT-RO-90-20-FFG-S</b>	Plastic lubricating roll for wheel flange	90 mm	20 mm	3
<b>LAT-RO-60-20-FFG-S</b>	Plastic lubricating roll for wheel flange	60 mm	20 mm	3

Figures



## Brushes

Thanks to the broad range of brush accessories, the lubrication dispensers can be ideally and professionally installed on the corresponding chain applications with round or square brushes. Exact dosage and precise feed substantially decrease lubricant consumption. Brushes can be combined with all Gruetzner lubricant dispensers.



Art. no.	Brushes	Length of bristles (mm)	Top feeding	Both-sided feeding	Material	Fig. no.
<b>SAT2041</b>	Round brush Ø 28 mm, thread R¼"	15	✓	-	Polyamide	1
<b>SAT2034</b>	Round brush Ø 28 mm, thread R¼"	45	✓	-	Polyamide	2
<b>GAT2038</b>	Square brush 25 mm width, thread G¼", 2 blind plugs included	20	✓	✓	Aluminium, polyamide	3
<b>GAT2035</b>	Square brush 40 mm width, thread G¼", 2 blind plugs included	20	✓	✓	Aluminium, polyamide	4
<b>GAT2036</b>	Square brush 70 mm width, thread G¼", 2 blind plugs included	20	✓	✓	Aluminium, polyamide	5
<b>GAT2037</b>	Square brush 100 mm width, thread G¼", 2 blind plugs included	20	✓	✓	Aluminium, polyamide	6
<b>SAT2034-HT</b>	High temperature round brush Ø 25 mm, thread G¼", up to 300 °C	45	✓	-	Brass, stainless steel	7
<b>SAT2036-HT</b>	High temperature square brush 57 mm width, thread G¼", up to 300 °C	28	✓	-	Stainless steel	8

Figures



## Applications of accessories









## Gruetzner sets

### Direct mounting

The best option for installing single-point lubricant dispensers is direct installation at the lubrication point. Lubrication nipple out, reducer in (if needed) and directly attach the lubrication dispenser. Please order the desired lubrication system separately.



**Please order lubricator separately**

Art. no.	Starter set: direct mounting							Consisting of	Fig. no.	
<b>GL-Set-DM</b>	Starter set G-LUBE	✓	-	-	-	-	-	SAT1020 Reducer G $\frac{1}{4}$ " x G1/8" SAT1022 Reducer G $\frac{1}{4}$ " x M6 SAT1024 Reducer G $\frac{1}{4}$ " x M8x1 SAT1026 Reducer G $\frac{1}{4}$ " x M10x1 SAT1041 Extension 50 mm SAT1001 Bent connection 45°	1	
<b>SOL-Set-DM</b>	Starter set Sololube	-	✓	-	-	-	-			
<b>LUB5-Set-DM</b>	Starter set LUB5	-	-	✓	-	-	-			
<b>GL-VIB-Set-DM</b>	Starter set GL-VIB	-	-	-	✓	-	-			
<b>LUB-S-B-Set-DM</b>	Starter set LUB-S-B	-	-	-	-	✓	-	SAT1020 Reducer G $\frac{1}{4}$ " x G1/8" SAT1022 Reducer G $\frac{1}{4}$ " x M6 SAT1024 Reducer G $\frac{1}{4}$ " x M8x1 SAT1026 Reducer G $\frac{1}{4}$ " x M10x1 LAT1099 Thread adapter M16x1.5 x G $\frac{1}{4}$ "	LAT-BAT-SA AI battery	2
<b>LUB-S-V-Set-DM</b>	Starter set LUB-S-V	-	-	-	-	✓	-	LAT-WI-0-5 connection cable		



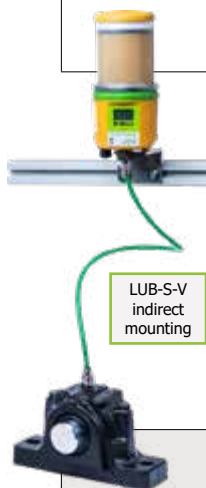
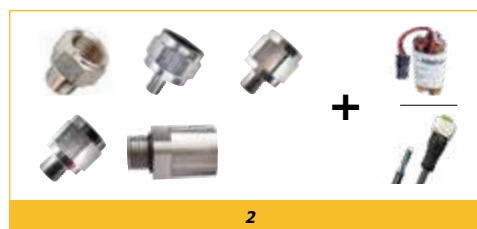



#### Figures









### Indirect mounting

If direct installation is not possible for structural reasons, lubricant dispensers can be installed indirectly. Our indirect installation starter sets include appropriate connectors, hose adapters and hoses to match the type of system. Please order the desired lubrication system separately.

**Please order lubricator separately**

Art. no.	Starter set: indirect mounting							Consisting of	Fig. no.
<b>GL-Set-IM</b>	Starter set G-LUBE	✓	-	-	-	-	-	GAT2010 Bracket for lubricator SAT2000 Hose Ø 8/6 mm, 1 m SAT1020 Reducer G $\frac{1}{4}$ " x G1/8" SAT1022 Reducer G $\frac{1}{4}$ " x M6 SAT1024 Reducer G $\frac{1}{4}$ " x M8x1 SAT1026 Reducer G $\frac{1}{4}$ " x M10x1 SAT1060 Hose adapter G $\frac{1}{4}$ " SAT1071 Hose adapter G $\frac{1}{4}$ "	1
<b>SOL-Set-IM</b>	Starter set Sololube	-	✓	-	-	-	-	SAT7800 Bracket for lubricator SAT2000 Hose Ø 8/6 mm, 1 m SAT1020 Reducer G $\frac{1}{4}$ " x G1/8" SAT1022 Reducer G $\frac{1}{4}$ " x M6 SAT1024 Reducer G $\frac{1}{4}$ " x M8x1 SAT1026 Reducer G $\frac{1}{4}$ " x M10x1 SAT1071 Hose adapter G $\frac{1}{4}$ "	2
<b>LUB5-Set-IM</b>	Starter set LUB5	-	-	✓	-	-	-		

Art. no.	Starter set: indirect mounting							Consisting of	Fig. no.
<b>GL-VIB-Set-IM</b>	Starter set GL-VIB	-	-	-	✓	-	-	SAT7800 Bracket for lubricator LAT8002 Hose Ø 6/4 mm, 3 m LAT7079 Hose adapter G1/4" LAT7084G Hose adapter M6 angled LAT7087G Hose adapter M10x1 angled LAT7076G Hose adapter G1/8" angled LAT7079G Hose adapter G1/4" angled GL-BAT-A AI battery	3
<b>LUB-S-B-Set-IM</b>	Starter set LUB-S-B	-	-	-	-	✓	-	LAT8803 Bracket for lubricator LAT8002 Hose Ø 6/4 mm, 3 m LAT7087 Hose adapter M10x1 LAT7084G Hose adapter M6 angled LAT7087G Hose adapter M10x1 angled LAT7076G Hose adapter G1/8" angled LAT7079G Hose adapter G1/4" angled	4
<b>LUB-S-V-Set-IM</b>	Starter set LUB-S-V	-	-	-	-	✓	-	LAT8803 Bracket for lubricator LAT8002 Hose Ø 6/4 mm, 3 m LAT7087 Hose adapter M10x1 LAT7084G Hose adapter M6 angled LAT7087G Hose adapter M10x1 angled LAT7076G Hose adapter G1/8" angled LAT7079G Hose adapter G1/4" angled	
<b>LUB-Set-B</b>	Starter set LUB-B	-	-	-	-	-	✓	LAT8002 2x Hose Ø 6/4 mm, 2 m LAT7084G 2x Hose adapter M6 angled LAT7087G 2x Hose adapter M10x1 angled LAT7076G 2x Hose adapter G1/8" angled LAT7079G 2x Hose adapter G1/4" angled	5
<b>LUB-Set-V</b>	Starter set LUB-V	-	-	-	-	-	✓	LAT8002 2x Hose Ø 6/4 mm, 2 m LAT7084G 2x Hose adapter M6 angled LAT7087G 2x Hose adapter M10x1 angled LAT7076G 2x Hose adapter G1/8" angled LAT7079G 2x Hose adapter G1/4" angled	



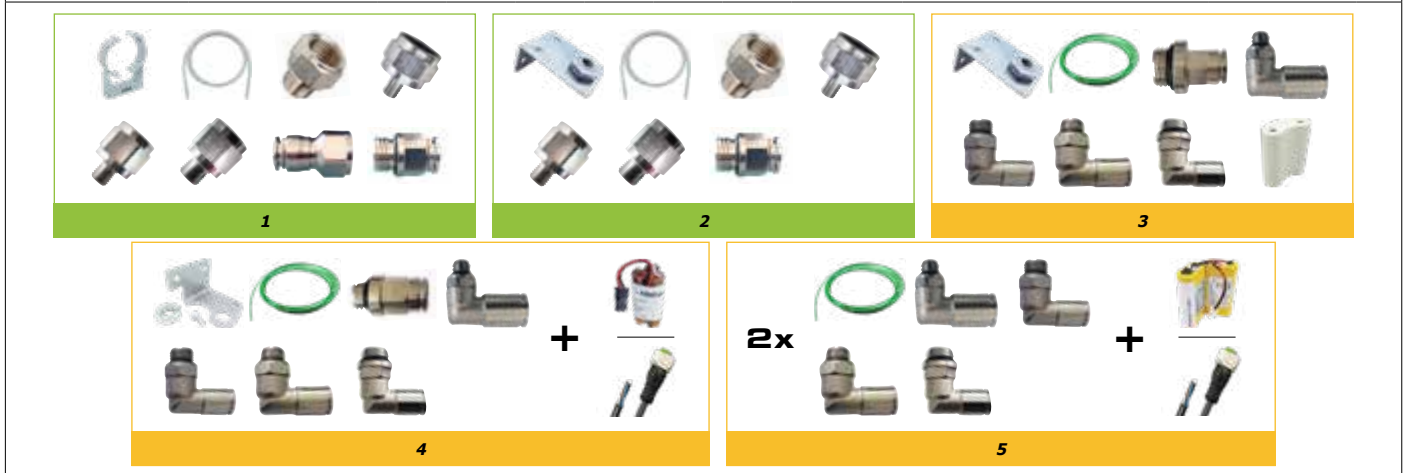

#### Figures



### Progressive distributor sets

To enable multipoint lubrication, progressive distributor sets suiting LUB-S-V are available. Those sets consist of a LUB-S-V drive unit, a progressive distributor (which can be chosen from 2 to 10 outlets on page 29), a special mounting bracket, a small piece of high-pressure hose and a hose connector. The sets are assembled completely and all components are pre-filled with lubricant. Please order the lubricant cartridge separately.

**Please order cartridge separately**











Art. no.	Progressive distributor set							Consisting of
<b>LUB-S-V-Set-PRV</b>	Progressive distributor set LUB-S-V	-	-	-	-	✓	-	LUB-S-V Drive LAT8804 Bracket for lubricator LAT8002 Hose Ø 6/4 mm, 5 cm LAT7087 Hose adapter M10x1 PRV Progressive distributor

#### Figures





**Model scheme**

Model	Distribution period	Lubricant volume	Operating pressure max.	Working voltage	Self-filling / refillable	Other	Page	
<b>Electrochemical single point lubrication</b>								
	<b>G-LUBE</b>	1-12 months	60 ml 120 ml 240 ml	5 bar 73 psi	3.0 V battery	-	 4	
<b>Electromechanical single point lubrication</b>								
	<b>Sololube</b>	1-12 months	60 ml 150 ml 250 ml	7.5 bar 108 psi	6.0 V battery or 24 VDC	✓	in battery mode:  6	
	<b>Lub5</b>	1, 3, 6, 12, 24 months	120 ml 250 ml	10 bar 145 psi	3.0 V battery	✓	refillable up to 4 times 8	
	<b>G-LUBE VIB</b>	1-12 months <i>(intermittent operation possible)</i>	60 ml 125 ml 250 ml	30 bar 435 psi	4.5 V battery	-	vibration sensor multipoint lubrication possible	
	<b>LUB-S</b>	1-24 months	125 ml 250 ml	35/50 bar 435/725 psi	4.5 V battery or 24 VDC	-	multipoint lubrication possible when operating at 24 VDC 14	
<b>Electromechanical multipoint lubrication</b>								
	<b>Lubricus B</b>	1-36 months or pause time	250 ml 400 ml	70 bar 1015 psi	6.0 V Li battery	-	1-2 outlets	10
	<b>Lubricus V</b>	1-36 months or pause time <i>(intermittent operation possible)</i>			-	10		
	<b>Lubricus D</b>	pause time <i>(individually adjustable)</i>			24 VDC	-	1-4 outlets external control / PLC	10
	<b>Lubricus C</b>				400 ml	-	1-4 outlets Lubricus Controller required	10



**GRUETZNER**  
AUTOMATIC LUBRICATION

## **Gruetzner GmbH – innovative solutions with high customer benefit**

Gruetzner GmbH is your specialist for automatic lubrication systems since 1993. Our user-friendly lubrication solutions are used in almost all areas of maintenance in every industry across the globe.

As an international established, family-owned enterprise flexibility and outstanding service are our core competencies. An individual, custom-built lubrication concept which is adjusted to your machines and constructions will gladly be developed by our experts.

We additionally take on responsibility for the environment with our modern lubrication solutions. By reducing lubricant and energy consumption as well as extending the service life of wear parts we achieve a significant reduction in CO<sub>2</sub> emissions in factories and plants all over the world.

### **Gruetzner GmbH**

Dagobertstr. 15

D-90431 Nuremberg, Germany

Tel: +49 911 277 399 0

Fax: +49 911 277 399 99

[sales@G-LUBE.com](mailto:sales@G-LUBE.com)

[www.G-LUBE.com](http://www.G-LUBE.com)

