

LUB-B-2

Battery powered for grease with two outlets



Figure 1: LUB-B-2 front view



Figure 2: LUB-B-2 side view

Item number

LUB-B-2

Intended use

The LUB-B-2 (two outlets) is designed for the supply of two lubrication points with grease or oil. Both outlets of the LUB-B-2 deliver alternately the same volume of lubricant.

Product description

The LUB-B-2 is a high efficient microprocessor controlled piston pump designed for specific and needs-oriented direct supply of lubrication points with grease. At this lubricant pump of the newest generation the lubricant interval and lubricant delivery volume are individually adjustable. The easy manual input of the parameters/data entry will be done by the stylus on the input field on the front side of the pump. The input menu is visualized on a LCD display above the input field.

Additionally the display offers the possibility to monitor the conditions of the pump (empty level, properly motor running and error indication). Furthermore occurring errors and empty level are indicated by an optical signal of a red LED in the display.

A special 3V lithium battery (primary cell, not rechargeable) is responsible for the power supply of the pump. This special battery is part of the accessory.

The lubricant is located above the pump drive unit in separate cartridges. The pre-filled lubricant cartridges (400ml) are part of the accessory.

Important remark

In order to ensure a trouble-free operation of the pump, don't depart the original hose connecting parts.



Technical data

Number of outlets		2
Temperature range	min.	-15°C/-4°F
	max.	+60°C/140°F
Max. pressure build-up during conveying		70 bar/1015 PSI
Protecting class		IP 54
Delivery volume per piston stroke		0,15ml
Piston strokes per lubrication interval	min.	1
	max.	30
Period for discharging of a 400ml- cartridge	min.	1 month
	max.	36 months
Battery life time	min.	Period for discharging of a cartridge
Lubricant	grease	oil and grease up to NLGI 2
Cartridge content	grease	400ml
Hose connector		rectangular, rotatable, for hose D=6 mm
Mounting orientation	grease	user-defined
Weight without battery and cartridge		ca. 1,4 kg
Software version		B02

Materials

Transparent upper cover of pump:	polyamide (impact-resistant, lubricant-resistant, UV-resistant)
Pressure plate	polyamide (impact-resistant, lubricant-resistant, UV-resistant)
Pressure spring	spring steel, zinc plated
Cartridge	polypropylene, polyethylene
Housing pump drive unit:	zinc, nickel plated
Cover pump drive unit:	zinc, nickel plated
Screws:	stainless steel, 1.4301
Hose connector parts:	brass, nickel plated

Assembly dimensions

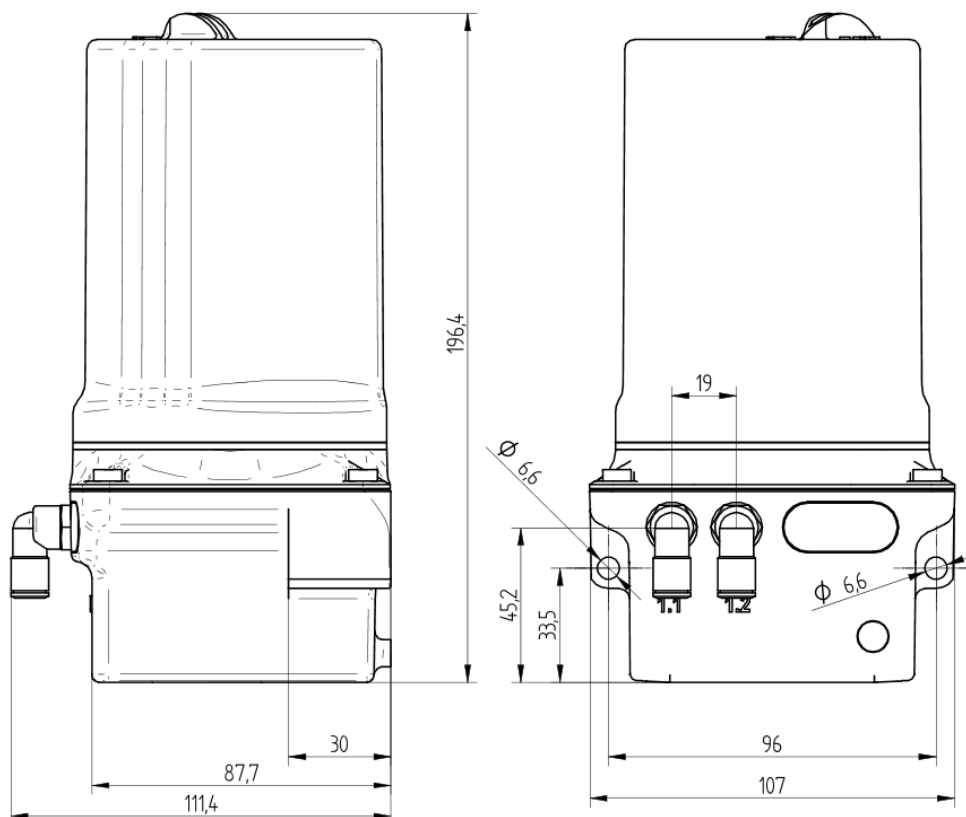



Scope of delivery

LUB-B-2 (without battery and cartridge)

Accessory

Description	Item number
Battery (Lithium, 3V, 6000mAh)	LAT-BAT-L
Grease cartridge according separate grease catalog	LUB-KA
Hose 6x4, black, operating pressure up to 70 bar/1015 PSI, length 1m	LAT8002
Mounting bracket, for mounting of the pump on horizontal surface	LAT8801

Other

The alternatively available LUB-B-1 have compared to the LUB-B-2 instead of two lubricant outlets only one outlet for the supply of lubricant.

At installation conditions with limited space note the needed installation dimensions to enable the opening of the pump cover for the change of the cartridge (320mm). See drawing below.

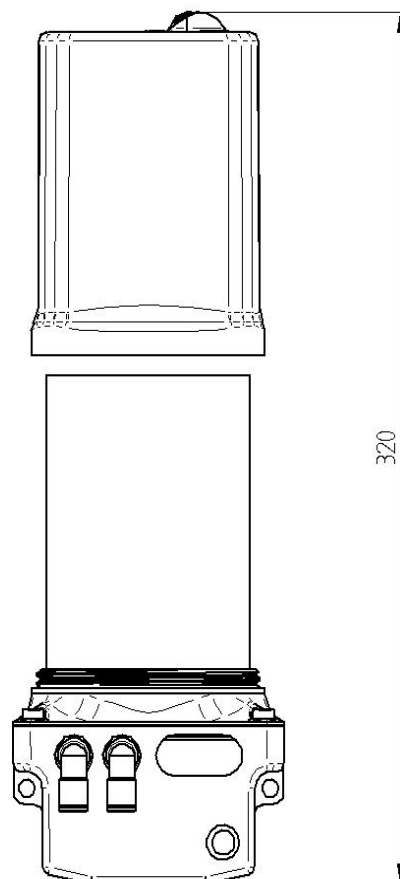

The before mentioned data and specifications are state of the art and status quo of our developments. In particular case these are no warranty for merchantability. Subject to change without prior notice.