

# LUBRICUS

User manual  
LUB-D



**GRUETZNER**  
AUTOMATIC LUBRICATION

## I. Revision history & imprint

### I.I Revision history

The present user manual is the original user manual.

This user manual is only valid for

#### **Product:**

Product designation: Lubricus D (LUB-D)  
Product revision: ---

#### **User manual:**

Date of creation: 02.2020  
Revision of the user manual: 0

This document is protected by copyright.

All rights for layout, content, texts and corporate design are reserved by Gruetzner GmbH, © 2020.

All rights, including those of photomechanical reproduction, duplication and distribution by means of special processes (e.g. data processing, data carriers and data networks), even in part and/or in extracts, are reserved by Gruetzner GmbH.

The content and technical specifications are subject to change without notice.

### I.II Imprint

Address:

Gruetzner GmbH  
Kohlenhofstr. 60  
90443 Nuremberg, Germany  
Tel: +49 (0)911 277 399-0  
Fax: +49 (0)911 277 399-99  
info@G-LUBE.com  
www.G-LUBE.com

Commercial Register of Nuremberg Local Court: HRB 12109

USt.-ID: DE 160441123

CEO: Volker Grütznér

## I.III Table of contents

Chapter	Content	Page
<b>I.</b>	<b>Revision history &amp; imprint</b>	<b>02</b>
I.I	Revision history	02
I.II	Imprint of the manufacturer, distribution and service	02
I.III	Table of contents	03
<b>1.</b>	<b>General information about this manual</b>	<b>05</b>
1.1	Signal words	05
1.2	Warning symbols	06
1.3	Structure of the safety instructions	06
1.4	Symbols for information	06
<b>2.</b>	<b>Safety</b>	<b>07</b>
2.1	EC/EU Directive	07
2.2	Hazards	07
2.3	Staff	07
2.4	Reasonably predictable misuse	07
2.5	Usage for the intended purpose	08
2.6	Warranty and Liability	08
2.7	General safety instructions	09
<b>3.</b>	<b>Description of function</b>	<b>10</b>
3.1	General information	10
3.2	Nameplate and designation	11
3.3	Scope of delivery	11
3.4	Technical data	12
<b>4.</b>	<b>Transport and storage</b>	<b>13</b>
4.1	Packaging	13
4.2	Transport	13
4.3	Storage	13
<b>5.</b>	<b>Versions</b>	<b>14</b>
5.1	LUB-D-1	14
5.2	LUB-D-2	15
5.3	LUB-D-1-1	16
5.4	LUB-D-3	17
5.5	LUB-D-4	18

Chapter	Content	Page
<b>6.</b>	<b>Mounting</b>	<b>19</b>
6.1	Preparations	19
6.2	Assembly	19
6.3	Commissioning	23
<b>7.</b>	<b>Operation and settings</b>	<b>24</b>
7.1	General information	24
<b>8.</b>	<b>Input and output signals - external control (PLC)</b>	<b>25</b>
8.1	Pin assignment	25
8.2	Input signals	26
8.2.1	Control signal 2 seconds	27
8.2.1	Control signal 5 seconds	29
8.2.1	Control signal 8 seconds	31
8.2.2	Control signal 12 seconds	33
8.2.3	Control signal 14 seconds	35
8.3	Output signals/LCD messages	37
8.3.1	Empty level (E1)	38
8.3.2	Error: overload (E2)	40
8.3.3	Error: undervoltage (E3)	41
8.3.4	Fatal error (E4)	42
<b>9.</b>	<b>Maintenance and disposal</b>	<b>43</b>
9.1	Maintenance schedule	43
9.1.1	Visual check	44
9.1.2	Cleaning	44
9.1.3	Recommissioning after maintenance	44
9.2	Cartridge change	45
9.3	Disposal	48
<b>10.</b>	<b>Released accessories</b>	<b>49</b>
10.1	Lubricants	50
10.2	Tube lengths	50
<b>11.</b>	<b>Appendix</b>	<b>51</b>
11.1	Dimension sheet and installation dimensions	51
11.2	EC/EU declaration of conformity	52
11.3	Spare parts	53
11.4	Flowchart pulse control mode PUL	54

## 1. General information about this manual

This user manual contains all necessary information to use Lubricus D, hereinafter referred to as LUB-D, safely and as intended. In the event that supplementary sheets are attached to these instructions, the information and data contained there are valid and replace the corresponding information in this user manual. Any contradictory information contained in this user manual thus becomes invalid. If you have any questions regarding special applications, please contact Gruetzner GmbH (chapter I.II).

The actual and factual operator must ensure and guarantee that these instructions, including any supplementary sheets, have been read and understood by all persons responsible for the installation, operation or maintenance of LUB-D. Therefore, keep these instructions in a suitable place, ideally in an easily accessible place in the surrounding area of LUB-D.

Inform your colleagues who work in the local area of the machine about safety instructions so nobody gets hurt.

This manual was written in German, all other language versions are translations of this manual.

### 1.1 Signal words

The following signal words are used in this manual to draw your attention to possible dangers, prohibitions and other important information:

**DANGER**

This signal word points you to an immediate and threatening risk of serious injury or death.

**WARNING**

This signal word indicates a potentially imminent danger which can result in serious injury or even death.

**CAUTION**

This signal word indicates a potentially imminent danger that can result in minor to severe injuries.

**NOTICE**



This signal word indicates a potentially imminent danger which can result in damage to property.

**INFORMATION**

This signal word refers to practical application tips or particularly important information when using LUB-D.

## 1.2 Warning symbols

The following warning symbols are used in this user manual to alert you to hazards, prohibitions and important information:

		
General warning sign	Electricity hazard	Flammable material



## 1.3 Structure of the safety instructions

The safety instructions in this user manual are structured according to the following system:

	<b>CAUTION</b>
	<p><b>This text explains the consequences of disregarding the reference.</b></p> <ul style="list-style-type: none"> <li>This text shows what to do as an instruction.</li> </ul>

## 1.4 Symbols for information

The following information symbols are used in the text and instructions in this manual:

-  Requests you to take action
-  Shows the consequences of an action
-  Additional information about the action

## 2. Safety

All persons working with LUB-D must follow these operating instructions, in particular the safety instructions and the rules and regulations applicable at the place of use. Generally applicable legal regulations and other rules as well as the relevant rules and regulations for accident prevention (e.g. personal protective equipment (PPE)) and environmental protection must be observed.

### 2.1 EC/EU Directive

Within the scope of the EC/EU Directive, (re)commissioning of a machine on which LUB-D has been installed and/or fitted is prohibited until it has been clearly established that the machine complies with the provisions of the applicable directive. An EC/EU declaration of conformity for LUB-D can be found in the appendix (chapter 11.2).

### 2.2 Hazards

In order to avoid danger to the user or damage to the machine on which LUB-D is used, LUB-D may only be used for its intended purpose (chapter 2.5) and in a technically safe condition.

Always inform yourself about the general safety instructions (chapter 2.7) before starting to work.

### 2.3 Staff

Only qualified staff who has read and understood this manual may work with LUB-D. Local and/or company regulations apply accordingly.

### 2.4 Reasonably predictable misuse

Any use of LUB-D which exceeds the maximum permissible technical data is generally considered to be improper and therefore prohibited.

## 2.5 Usage for the intended purpose

The following points must be observed for the intended purpose of using LUB-D:

- LUB-D is exclusively approved for industrial use.
- LUB-D may be used in accordance with the technical data (chapter 3.4) exclusively.
- Unauthorized structural alterations to LUB-D are not permitted.
- Read the user manual and act accordingly.
- During operation of LUB-D, a visual inspection of LUB-D as well as of the lubrication point must be carried out regularly. Any anomalies must be eliminated immediately and the cause must be rectified.
- Refilling the cartridge is not permitted.
- LUB-D may not be opened or disassembled.
- Only lubricants approved by the manufacturer may be used.
- Relevant regulations and rules on work safety, accident prevention and environmental protection must be observed.
- Work and activities with and on LUB-D are only permitted with appropriate authorization (chapter 2.3).

All other uses than the aforementioned intended usage or the disregard of one of the above points shall be deemed improper usage. In this case no liability and/or warranty is assumed.

## 2.6 Warranty and Liability





If the following items are disregarded, all warranty and liability claims for personal injury and/or damage to property are excluded:

- non-observance of the instructions on transport and storage;
- misuse;
- improper or unperformed maintenance or repair work;
- improper assembly / disassembly or improper operation;
- operation of LUB-D with defective protective devices;
- operation of LUB-D without lubricant;
- operation of LUB-D with non-approved lubricant;
- operation of heavily contaminated LUB-D;
- modifications or alterations which may be carried out without the written permission of Gruetzner GmbH have taken place;
- opening and/or partial or complete disassembly of LUB-D.



## 1.2 General safety instructions

The following safety instructions are given for LUB-D:

	<p style="text-align: center;"><b>DANGER</b></p> <p><b>Damaged or flawed electrical connections or unlicensed hot components lead to heavy injuries or even death.</b></p> <ul style="list-style-type: none"> <li>• All work on electrical connections shall be provided by qualified personnel only.</li> <li>• Immediately change damaged cables or plugs.</li> </ul>
	<p style="text-align: center;"><b>NOTICE</b></p> <p><b>Loose or overloaded screw connections can cause damage to LUB-D.</b></p> <ul style="list-style-type: none"> <li>• Mount and check all screw connections with the permissible torques specified for this purpose. Use a calibrated torque wrench.</li> </ul>
	<p style="text-align: center;"><b>WARNING</b></p> <p><b>Lubricants are flammable.</b></p> <ul style="list-style-type: none"> <li>• In case of fire do not use a water jet to extinguish.</li> <li>• In case of fire only use suitable extinguishing agents such as powder, foam and carbon dioxide.</li> <li>• Observe the relevant safety instructions of the lubricant manufacturer on the safety data sheet of the lubricant used.</li> </ul>
	<p style="text-align: center;"><b>CAUTION</b></p> <p><b>Lubricants can cause skin irritations.</b></p> <ul style="list-style-type: none"> <li>• Avoid direct skin contact.</li> </ul>
	<p style="text-align: center;"><b>NOTICE</b></p> <p><b>Lubricants can contaminate soil and water.</b></p> <ul style="list-style-type: none"> <li>• Use and dispose lubricants properly.</li> </ul>

## 3. Description of function

### 3.1 General information

LUB-D is designed as an extremely compact double piston pump. The two pistons run force-controlled and counter-rotating. LUB-D is available with one, two, three or four lubricant outlets (see chapter 5). The outlets are secured by an integrated non-return valve. Approx. 0.16 cm<sup>3</sup> of lubricant is pumped during each dispensing operation.

The present Lubricus D needs to be embedded into an external control (PLC). It provides an electrical interface which is used to control and command LUB-D.

Furthermore, output signals of LUB-D enable a remote control which shows possible error messages (e.g. empty cartridge) and allows to query the status anytime. By means of various input signals processed by the microelectronics LUB-D is controlled to supply the lubrication point with the ideal amount of lubricant.

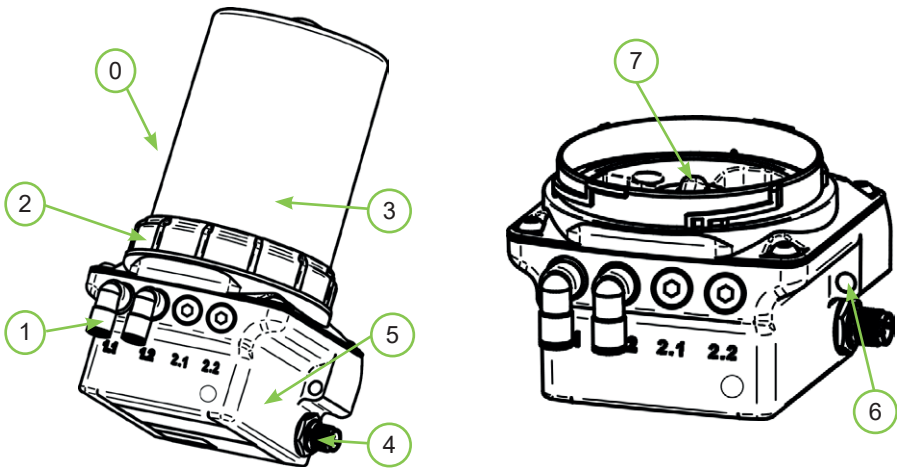

Fig. 1: Overview LUB-D

No.	Description
0	Lubricus D (LUB-D)
1	Lubricant outlet(s) (different versions available)
2	Retaining ring
3	Housing
4	M12x1 electrical interface
5	Nameplate with designation, CE mark and serial number
6	Clearance hole for assembly
7	Lubricant inlet with thread for cartridge

## 3.2 Nameplate and designation

The nameplate of LUB-D is visibly attached to the side of the pump itself. There the CE mark and the serial number of LUB-D are visible. Refer to chapter 3, Fig. 1 for the location of the nameplate and serial number.

## 3.3 Scope of delivery

LUB-D is available in several different versions. They differ in the number and type of lubricant outlets and the scope of accessories supplied.

## 3.4 Technical data

<b>Housing</b>			
dimensions without cartridge	width x height x depth	107 x 56.5 x 108	mm
dimensions with cartridge 400 ml		107 x 198.5 x 108	
weight (without cartridge)	appx.	1050	g
mounting options		holes for screw M6	
mounting position		upright	
material housing		zinc die-cast / PA 6.6 GF30 / POM	
material outlet		nickel-plated brass	
operating temperature		-15 ... +60*	°C
<b>Lubricant and hydraulic</b>			
cartridge volume		400	cm <sup>3</sup>
lubricant characteristics		oils and greases up to NLGI 2	
number of outlets		1 / 2 / 3 / 4	
hydraulic connection		via PA tube	
number of lubrication points		without accessories: up to 4* with splitters: up to 16* with progressive distributors: up to 40*	
max. pressure		70 (-10%/+15%)	bar
grease delivery	per stroke	0.16 (-5%)	cm <sup>3</sup>
<b>Electrics</b>			
operating voltage		24 (+/- 5%)	V
protection		0.75 (slow blow)	A
protection class		IP 54	
current draw		$I_{\max} < 0.3$ $I_{\text{rest}} < 0.025$	A
Please see chapters 7 and 8 for more information about electrics.			

\* The stated value is down to the individual application and may extensively differ in some cases (depending on the lubricant and further conditions).

## 4. Transport and storage

### 4.1 Packaging

LUB-D is delivered in an outer packaging (cardboard box) and - depending on the scope of delivery - with a lubricant cartridge and other accessories in the same package. To protect them from moisture and dirt they are also packed in PE films.

Dispose the packaging materials at designated disposal points in compliance with the relevant national and company regulations.

After receiving LUB-D check the delivery note for completeness and correctness. Any missing parts or damages must be reported immediately to the forwarding agent, the insurance company or Gruetzner GmbH in writing.

### 4.2 Transport

NOTICE	
	<p><b>Hard shocks due to e.g. falling or setting down too hard can damage LUB-D.</b></p> <ul style="list-style-type: none"> <li>• Do not throw LUB-D.</li> <li>• When using lifting equipment only use hoists and load handling attachments in perfect condition and with sufficient load capacity.</li> <li>• The permissible lifting weight of the lifting device must not be exceeded.</li> </ul>

### 4.3 Storage

Store LUB-D in its original packaging in a vertical position in a dry, frost-free environment at an ambient temperature of +5 °C to +30 °C. The maximum storage time in unopened condition is 2 years.

The so-called "first-in-first-out" principle (fifo) is recommended for storage logistics.

## 5. Versions

LUB-D is designed as a compact central lubrication unit for supplying one or more lubrication points. Depending on the specific application LUB-D can also reliably and cleanly supply a limited number of lubrication points with lubricant. In this case accessories (e.g. splitters, progressive distributors or lubrication gears) can be connected to LUB-D in order to extend the number of lubrication points beyond the number of outlets. LUB-D is available as a version with one and as a version with two pump bodies. The outlets of pump body (PB) 1 are marked on the housing with 1.1 and 1.2, the outlets of pump body 2 with 2.1 and 2.2.

### 5.1 LUB-D-1

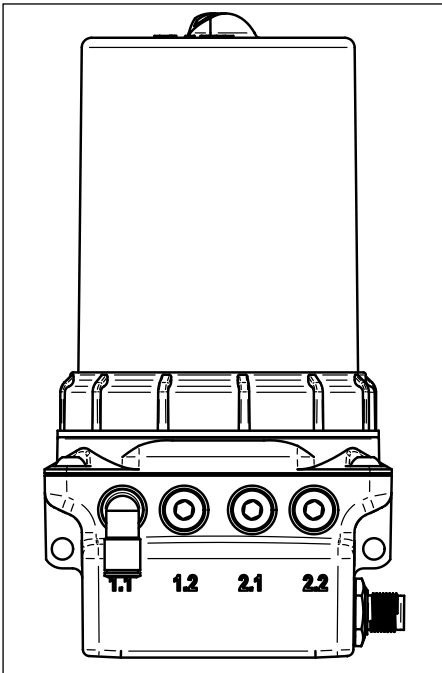

Number of pump units	1
Number of outlets	1
Differences in dosing volume per pump unit	not applicable (only one pump unit)

LUB-D-1's theoretical two outlets of the built-in one pump unit are combined internally. The outlet is supplied with 0.16 cm<sup>3</sup> lubricant per stroke.

## 5.2 LUB-D-2

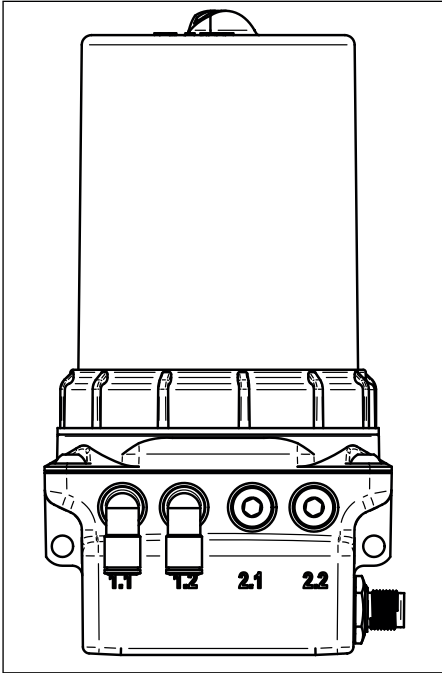

Number of pump units	1
Number of outlets	2
Differences in dosing volume per pump unit	not applicable (only one pump unit)

LUB-D-2's two outlets are supplied with the same quantity of lubricant. One outlet is supplied with 0.16 cm<sup>3</sup> lubricant per stroke. The outlets are supplied with lubricant one after the other.

## 5.3 LUB-D-1-1

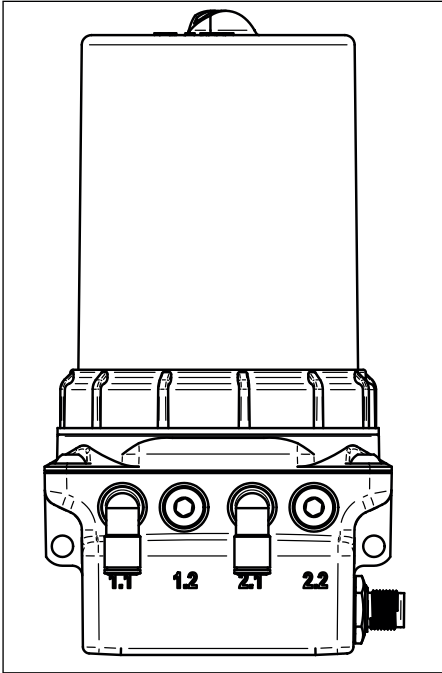

Number of pump units	2
Number of outlets	2
Differences in dosing volume per pump unit	yes

LUB-D-1-1's theoretical two outlets per installed pump unit are combined internally. One outlet is supplied with 0.16 cm<sup>3</sup> lubricant per stroke. The outlets are supplied with lubricant one after the other.

LUB-D-1-1 allows to set dosing volume differences from outlet 1.1 to outlet 2.1 by individual control of the two pump bodies. An explanation of the different control signals can be found in chapter 8.2.



## 5.4 LUB-D-3

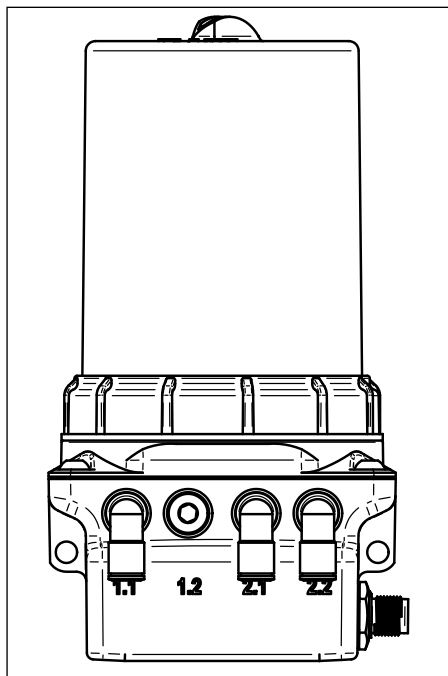

Number of pump units	2
Number of outlets	3
Differences in dosing volume per pump unit	yes

LUB-D-3's theoretical two outlets of the first pump body are internally combined into one outlet 1.1. One outlet is supplied with  $0.16 \text{ cm}^3$  lubricant per stroke. The outlets are supplied with lubricant one after the other.

LUB-D-3 allows you to set dosing volume differences from outlet 1.1 to outlets 2.1 and 2.2 by controlling the two pump bodies individually. An explanation of the different control signals can be found in chapter 8.2.

ⓘ If the two pump units are controlled equally, outlet 1.1 is supplied with twice the amount of lubricant of outlets 2.1 or 2.2, due to the internal combination of the outlets of the first pump unit.

## 5.5 LUB-D-4

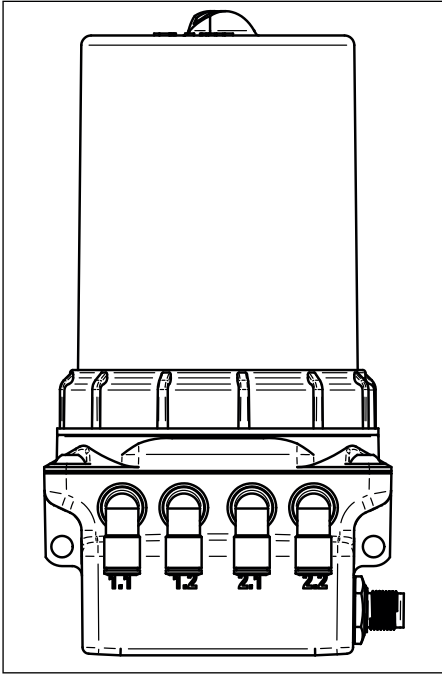

Number of pump units	2
Number of outlets	4
Differences in dosing volume per pump unit	yes

At LUB-D-4 each possible outlet is operated individually. One outlet is supplied with 0.16 cm<sup>3</sup> lubricant per stroke. The outlets are supplied with lubricant one after the other.

LUB-D-4 allows you to set dosing volume differences from outlets 1.1 and 1.2 to outlets 2.1 and 2.2 by individually controlling the two pump bodies. An explanation of the different control signals can be found in chapter 8.2.

## 6. Mounting

### 6.1 Preparations

Before starting to work, inform yourself in detail about LUB-D using this user manual; and follow the general safety instructions (section 2.7) in particular. Prepare the installation site carefully.

	NOTICE
	<p><b>Pressurised air can damage the seals of LUB-D and can transport dirt and foreign matter into LUB-D or the lubricant.</b></p> <ul style="list-style-type: none"> <li>• Do not use pressurised air.</li> <li>• Make sure that there is no coarse dirt in the mounting area.</li> </ul>

### 6.2 Assembly

1	<p><b>Condition as delivered</b></p> <p>LUB-D is delivered in a cardboard box. Depending on the version ordered further accessories such as battery, lubricant cartridge or brackets are included. It also contains a short manual for experienced users to start up and assemble the unit for the first time.</p>
---	--

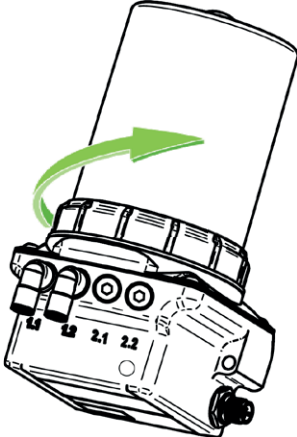
2	<div style="display: flex; align-items: center;">  <div style="margin-left: 20px;"> <p><b>Remove housing from power unit</b></p> <ul style="list-style-type: none"> <li>✦ Separate the housing from the power unit by turning the retaining ring counterclockwise.</li> <li>ⓘ Make sure that no dirt, water or foreign bodies enter the lubricant inlet.</li> </ul> </div> </div>
---	---

3

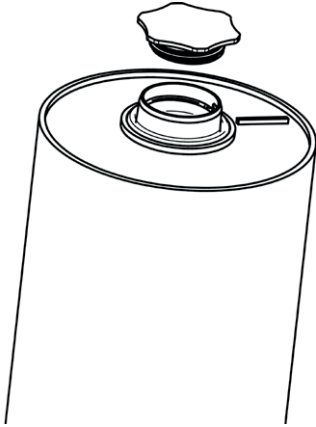

## Remove cartridge cap

✦ Turn the cap of the lubricant cartridge counterclockwise and pull it off.

ⓘ Pay attention to cleanliness when carrying out the work. Be sure to prevent dirt, liquids and foreign bodies from entering the cartridge.

4

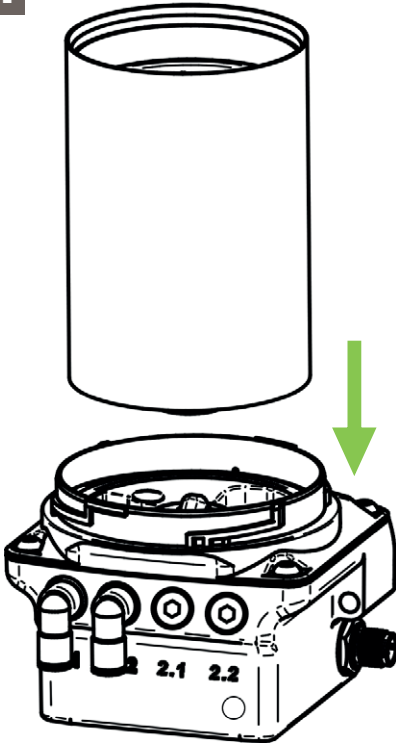

## Mount lubricant cartridge

- ✦ Place the full lubricant cartridge on LUB-D (label facing front).
- ✦ Turn the lubricant cartridge clockwise onto LUB-D.

ⓘ The end position is reached after two full rotations when the label of the lubricant cartridge is aligned with the front of LUB-D.

5

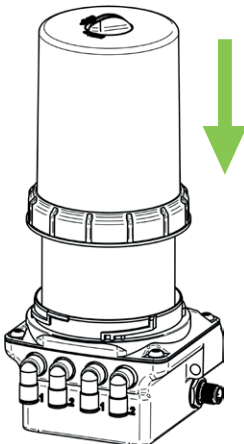

## Assemble housing on power unit

- ✦ Place the dismantled housing on LUB-D and press it onto the power unit.
- ✦ Fasten the housing to the power unit by turning the retaining ring clockwise.

ⓘ The retaining ring must snap into place when turning and be completely tightened.

**6**

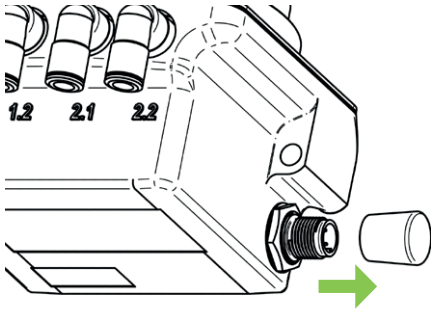

**Remove protective cap on the side of LUB-D**

✦ Remove the black protective cap from the electrical interface on the side of LUB-D.

**7**

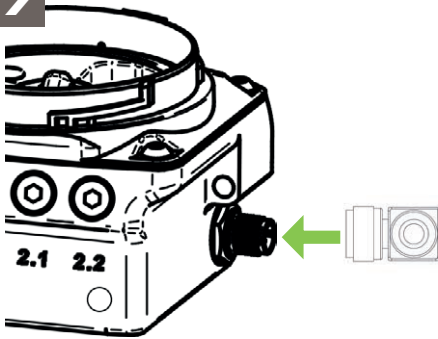

**Connect electrical interface**

✦ To connect LUB-D with an external power supply system add a proper connecting cable to the electrical interface on the side of LUB-D.

ⓘ Depending on the application connecting cables with both straight or angled sockets can be used.

ⓘ For more details on connecting cables please see chapter 8.1.

## DANGER



**Damaged or flawed electrical connections or unlicensed hot components lead to heavy injuries or even death.**

- All work on electrical connections shall be provided by qualified personnel only.
- Immediately change damaged cables or plugs.
- Before working on electrical installations, always follow the five safety regulations of electrical engineering:
  - Isolate
  - Protect against accidental restart
  - Ensure all parts are deenergized
  - Ground and short-out
  - Cover nearby hot components

## 6.3 Commissioning

Mount LUB-D carefully according to the steps described in chapter 5.2. Depending on the scope of delivery you must also carry out the following additional measures for first-time commissioning:

### 1. Mechanical fastening

Fix LUB-D mechanically. Pay particular attention to the maximum tightening torques.

### 2. Electrical connection

Connect LUB-D with an external power supply system (e.g. PLC) by adding a proper connecting cable to the electrical interface on the side of LUB-D. Thus LUB-D is switched on.

### 3. Check the assembly

Make sure that LUB-D is assembled properly and completely. In particular, the external power supply system has to be connected and a lubricant cartridge must have been fitted.

### 4. Execute FIL function

Execute the 12 seconds control signal. The detailed description can be found in chapter 8.2.4. LUB-D performs a certain number of strokes and transports lubricant from the cartridge to the outlet.

### 5. Hydraulic connection

Connect the consumer hydraulically to LUB-D. If you connect tubes to LUB-D make sure that tubes and connectors are installed tightly, cleanly and correctly.

① Ideally, use tubes prefilled with the appropriate lubricant.

### 6. Check the settings on LUB-D

Check the required values for the lubrication point at the factory settings of LUB-D and adjust them if necessary. Changes at LUB-D can only be made by adjusting the PLC.

## 7. Operation and settings

### 7.1 General information

What you should know about operating and setting LUB-D:

✓ The disposable interchangeable cartridge with 400 ml lubricant guarantees a controlled and constant quality of the lubricant and is filled bubble-free. LUB-D allows a high supply security of the lubrication point and prevents failures.

✓ LUB-D cannot be used without a lubricant cartridge. Depending on the version ordered the cartridge can already be included in the scope of delivery and may already be connected and installed in LUB-D.

✓ If you have any questions about your application and the correct settings for LUB-D please contact the manufacturer (chapter I.II).

✓ LUB-D must be integrated into a control system (PLC) and must be commanded and controlled via the PLC. LUB D delivers one or more strokes (one stroke = 0.16 cm<sup>3</sup>) depending on the signals of the external control (PLC). Depending on the internal status of LUB-D (e.g. cartridge empty) different output signals are issued.

✦ Make sure that your PLC program is appropriate for your application and that the lubrication point is supplied with the correct amount of lubricant per time unit. If this is the case, you can operate LUB-D. If this is not the case, change your PLC program accordingly.

① To use LUB-D it first has to be properly mounted and installed. The installation is very simple and described in detail in chapter 6.2.

① If you order a factory-provided special version of LUB-D the information contained in the supplement is authoritative.



## 8. Input and output signals - external control (PLC)

LUB-D operates as a pulse-controlled lubrication system only if unalterable input signals (high level) are transmitted from the PLC to LUB-D via PIN 2 in a defined sequence. LUB-D signals the respective status to the PLC via high/low levels which can be tapped off at PIN 4 and thus enables comprehensive control or, by suitable programming of the PLC, differentiated evaluation of the different states. To integrate LUB-D into an external control one input and one output must be provided on the control side.

### 8.1 Pin assignment

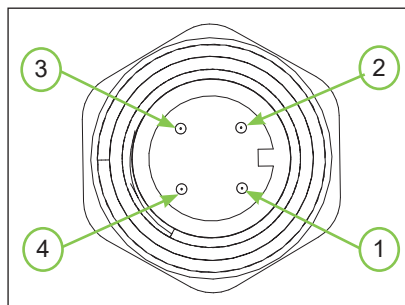

PIN assignment (PLC)		
PIN	Assignment	Colour
1	+24 V DC	brown
2	Input Signal PLC→LUB-D	white
3	Ground	blue
4	Output Signal LUB-D→PLC	black
Type: M12x1 female connector; 4-pin, A-coded		

To electrically connect LUB-D to the PLC of your machine the device provides a 4-pin interface which is designed as a standard industrial M12x1 plug connection.

ⓘ LUB-D can be switched off completely by switching off the supply voltage. After reapplying the supply voltage LUB-D checks itself automatically but only operates after receiving an input signal from the PLC.

ⓘ To operate LUB-D via an external controller (PLC) a program corresponding to the communication protocol must be created in the PLC. A basic flowchart for commanding LUB-D can be found in the appendix (chapter 11.4).

ⓘ The output signal at PIN 4 can be tapped for further processing (e.g. indicator light or external control). The maximum permissible current output must not exceed  $I_{\max} < 20 \text{ mA}$ . No inductive load (e.g. relay) may be connected!

ⓘ After a long standstill of LUB-D a manually triggered single dispense is recommended. Please use the 2 seconds signal or 8 seconds signal depending on your model (chap. 8.2.1 and 8.2.3).

## 8.2 Input signals

LUB-D provides the following unalterably defined control signals (input signals) which must be transmitted from the PLC to LUB-D via PIN 2 of the electrical M12x1 interface as high level (+24 V DC).

The control signals must be generated as high level (+24 V) by the external controller (PLC) over certain times with a tolerance of +/- 0.1 seconds.

Signal length in seconds	Description	Function	Chap.	valid for
2 high	Signal 2 seconds	1 stroke PB1	8.2.1	D-1, D-1-1, D-2
5 high	Signal 5 seconds	1 stroke PB2	8.2.2	D-1-1, D-3, D-4
8 high	Signal 8 seconds	1 stroke PB1 and PB2	8.2.3	D-1-1, D-3, D-4
12 high	Signal 12 seconds	FIL function	8.2.4	D-1, D-1-1, D-2, D-3, D-4
14 high	Signal 14 seconds	Error acknowledgement	8.2.5	D-1, D-1-1, D-2, D-3, D-4

① The input signals that LUB-D can process depend on the version of LUB-D. Compare your LUB-D with the different models described in chapter 5 to find out which signals are important for your LUB-D and can be used for control. The designation of your LUB-D can be found on the nameplate attached to the side of LUB-D, see chapter 3.1, fig. 1.

① LUB-D only processes the control signals listed in the table up to a maximum length of 14 seconds. If a high level (+24 V DC) exceeds the defined tolerance level, LUB-D does not react. If a high level (+24 V DC) is applied to PIN 2 of the electrical interface for longer than 15 seconds LUB-D does not react.

## 8.2.1 Control signal 2 seconds

The control signal 2 seconds triggers a single dispensing process at pump body 1. After a specified pause time this control signal can be repeated or another control signal can be sent.

The operating states are output by LUB-D via PIN 4 as a high/low level and must be tapped and processed accordingly by the PLC.

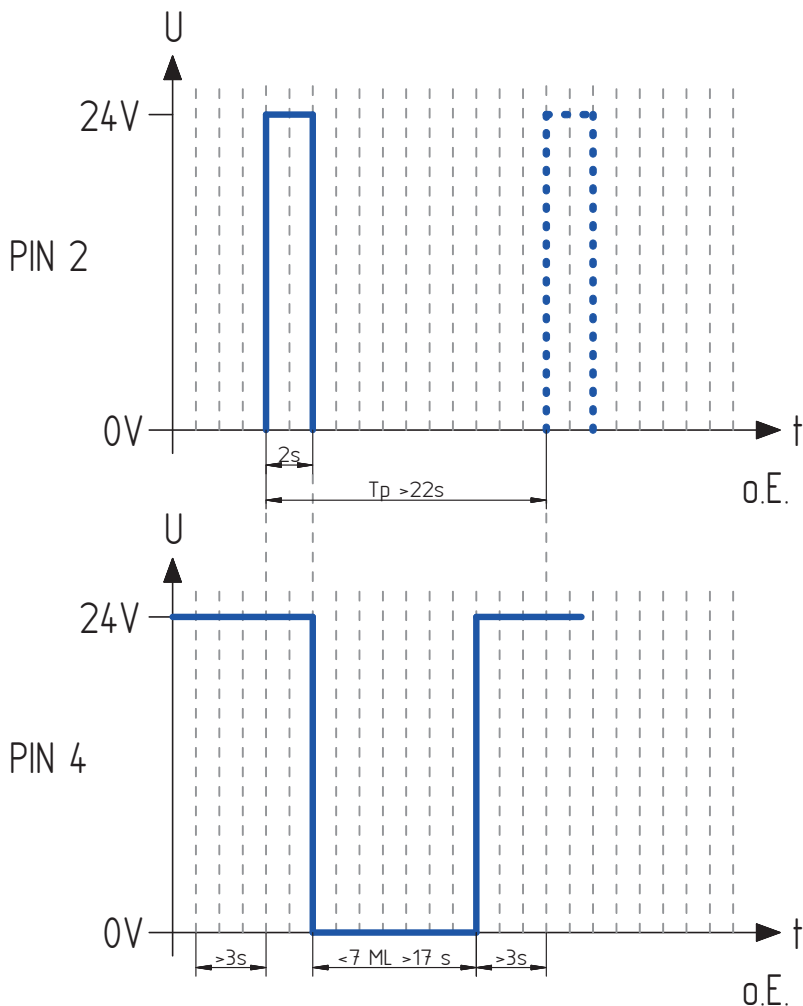

*T<sub>p</sub>*: Pause time  
*ML*: Motor running time

## Description:

✓LUB-D is properly connected to an external controller via the electrical interface and connected to the power supply.

✦ LUB-D sends a permanent output signal (high level) to PIN 4 which indicates to the external control (PLC) that it is ready for operation. This output signal must be permanently and continuously present for >3 seconds to control LUB-D by a PLC.

✦ The control signal 2 seconds with a signal length of 2 (1.9 ... 2.1) seconds high level can be sent to LUB-D from the external control (PLC).

✦ Immediately after the control signal drops the motor run (ML) of LUB-D starts and 0.16 cm<sup>3</sup> lubricant is conveyed to the outlet. Simultaneously, LUB-D sends a low level output signal to the external controller (PLC) to confirm the duration of the motor run (ML).

✦ The motor running time (ML) depends on various conditions, including the present or built up counterpressure in the hydraulic system and the temperature. The motor running time (ML) is 7...17 seconds.

✦ At the end of an error-free and successful motor run (ML) the output signal at LUB-D changes from a low level to a high level.

ⓘ A new control signal can be sent from the external controller (PLC) at the earliest of >3 seconds after the motor run ended error-free and successfully. In the meantime, LUB-D does not process any control signals.

ⓘ In order to ensure a reliable and unambiguous recognition of the control signal a pause must be observed. The control signal 2 seconds requires a pause time (Tp) of at least 22 seconds between two identical or different control signals.

ⓘ If the integrated microelectronics of LUB-D have detected an error during or immediately after the motor run (ML), this is transmitted to the external controller (PLC) by the corresponding output signal (chap. 8.3).

## 8.2.2 Control signal 5 seconds

The control signal 5 seconds triggers a single dispensing process at pump body 2. After a specified pause time this control signal can be repeated or another control signal can be sent.

The operating states are output by LUB-D via PIN 4 as a high/low level and must be tapped and processed accordingly by the PLC.

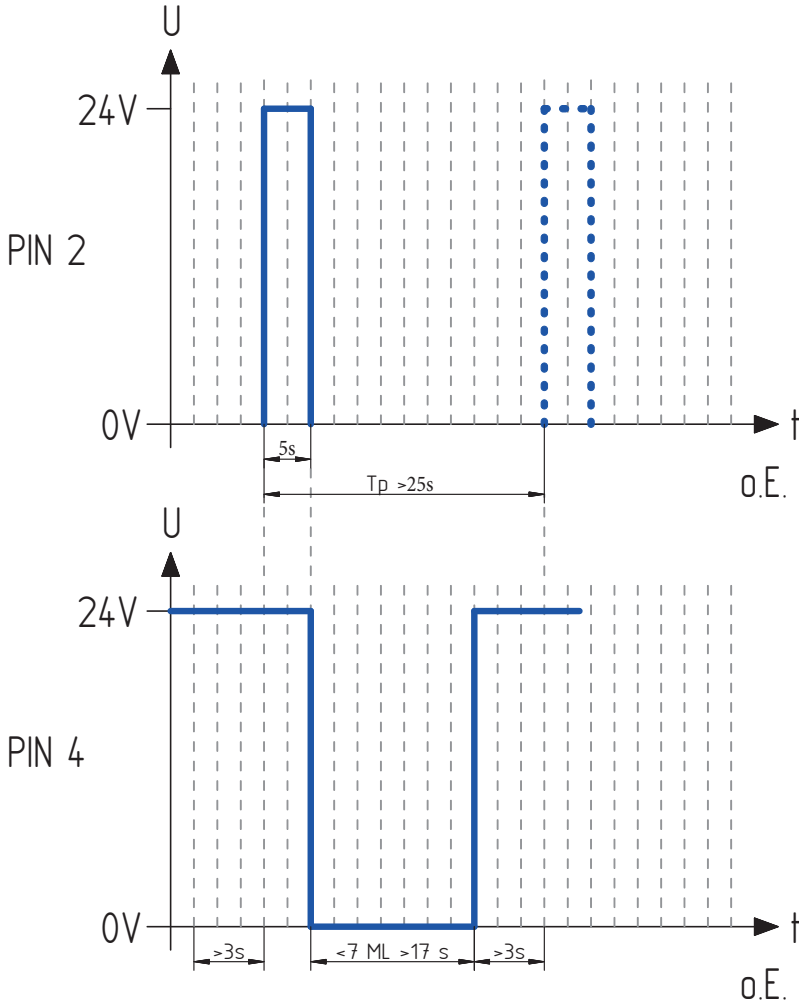

## Description:

✓LUB-D is properly connected to an external controller via the electrical interface and connected to the power supply.

✦ LUB-D sends a permanent output signal (high level) to PIN 4 which indicates to the external control (PLC) that it is ready for operation. This output signal must be permanently and continuously present for >3 seconds to control LUB-D by a PLC.

✦ The control signal 5 seconds with a signal length of 5 (4.9 ... 5.1) seconds high level can be sent to LUB-D from the external control (PLC).

✦ Immediately after the control signal drops the motor run (ML) of LUB-D starts and 0.16 cm<sup>3</sup> lubricant is conveyed to the outlet. Simultaneously, LUB-D sends a low level output signal to the external controller (PLC) to confirm the duration of the motor run (ML).

✦ The motor running time (ML) depends on various conditions, including the present or built up counterpressure in the hydraulic system and the temperature. The motor running time (ML) is 7...17 seconds.

✦ At the end of an error-free and successful motor run (ML) the output signal at LUB-D changes from a low level to a high level.

ⓘ A new control signal can be sent from the external controller (PLC) at the earliest of >3 seconds after the motor run ended error-free and successfully. In the meantime, LUB-D does not process any control signals.

ⓘ In order to ensure a reliable and unambiguous recognition of the control signal a pause must be observed. The control signal 5 seconds requires a pause time (Tp) of at least 25 seconds between two identical or different control signals.

ⓘ If the integrated microelectronics of LUB-D have detected an error during or immediately after the motor run (ML), this is transmitted to the external controller (PLC) by the corresponding output signal (chap. 8.3).

## 8.2.3 Control signal 8 seconds

If your model provides two pump bodies, the control signal 8 seconds triggers a single dispensing process at each pump body one after the other. After a specified pause time this control signal can be repeated or another control signal can be sent.

The operating states are output by LUB-D via PIN 4 as a high/low level and must be tapped and processed accordingly by the PLC.

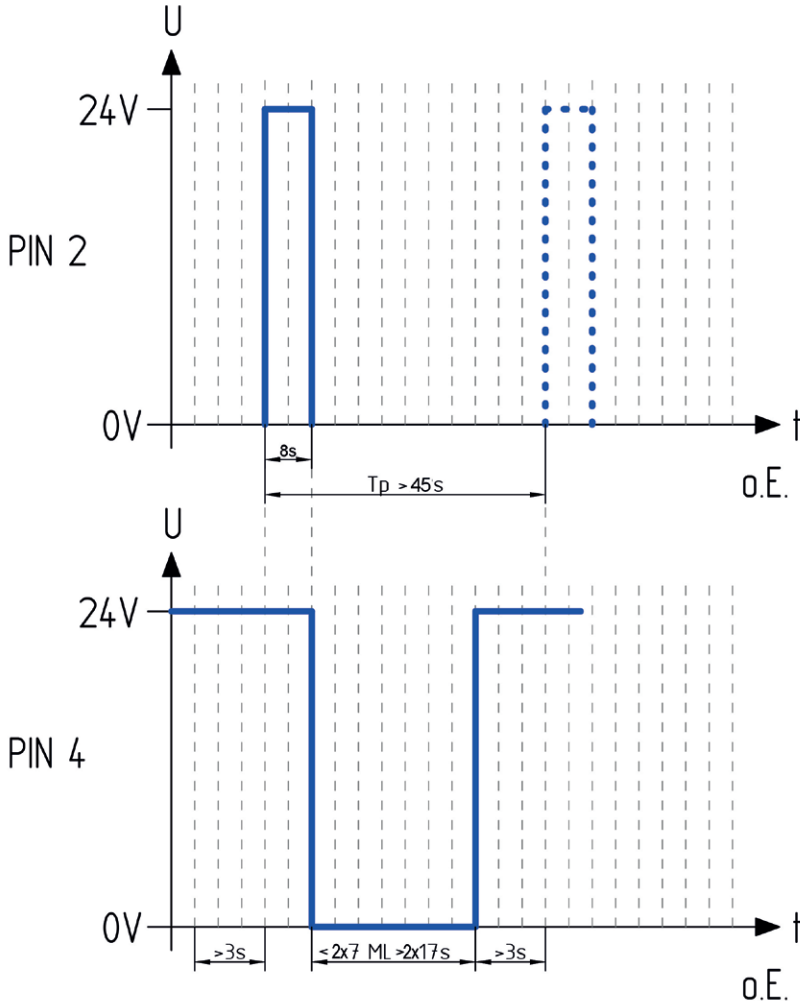

## Description:

✓ LUB-D is properly connected to an external controller via the electrical interface and connected to the power supply.

✦ LUB-D sends a permanent output signal (high level) to PIN 4 which indicates to the external control (PLC) that it is ready for operation. This output signal must be permanently and continuously present for >3 seconds to control LUB-D by a PLC.

✦ The control signal 8 seconds with a signal length of 8 (7.9 ... 8.1) seconds high level can be sent to LUB-D from the external control (PLC).

✦ Immediately after the control signal drops the motor run (ML) of LUB-D starts and 0.16 cm<sup>3</sup> lubricant is conveyed to the outlet. Simultaneously, LUB-D sends a low level output signal to the external controller (PLC) to confirm the duration of the motor run (ML).

✦ The motor running time (ML) depends on various conditions, including the present or built up counterpressure in the hydraulic system and the temperature. The motor running time (ML) is 2x 7...17 seconds.

✦ At the end of an error-free and successful motor run (ML) the output signal at LUB-D changes from a low level to a high level.

ⓘ A new control signal can be sent from the external controller (PLC) at the earliest of >3 seconds after the motor run ended error-free and successfully. In the meantime, LUB-D does not process any control signals.

ⓘ In order to ensure a reliable and unambiguous recognition of the control signal a pause must be observed. The control signal 8 seconds requires a pause time (Tp) of at least 45 seconds between two identical or different control signals.

ⓘ If the integrated microelectronics of LUB-D have detected an error during or immediately after the motor run (ML), this is transmitted to the external controller (PLC) by the corresponding output signal (chap. 8.3).



## 8.2.4 Control signal 12 seconds

The control signal 12 seconds triggers the FIL function by the external control. A total of 40 dispensing operations are carried out automatically one after the other. After a certain pause time this control signal can be repeated or another control signal can be sent. The operating states are output by LUB-D via PIN 4 as high/low levels and must be tapped and processed accordingly by the PLC.

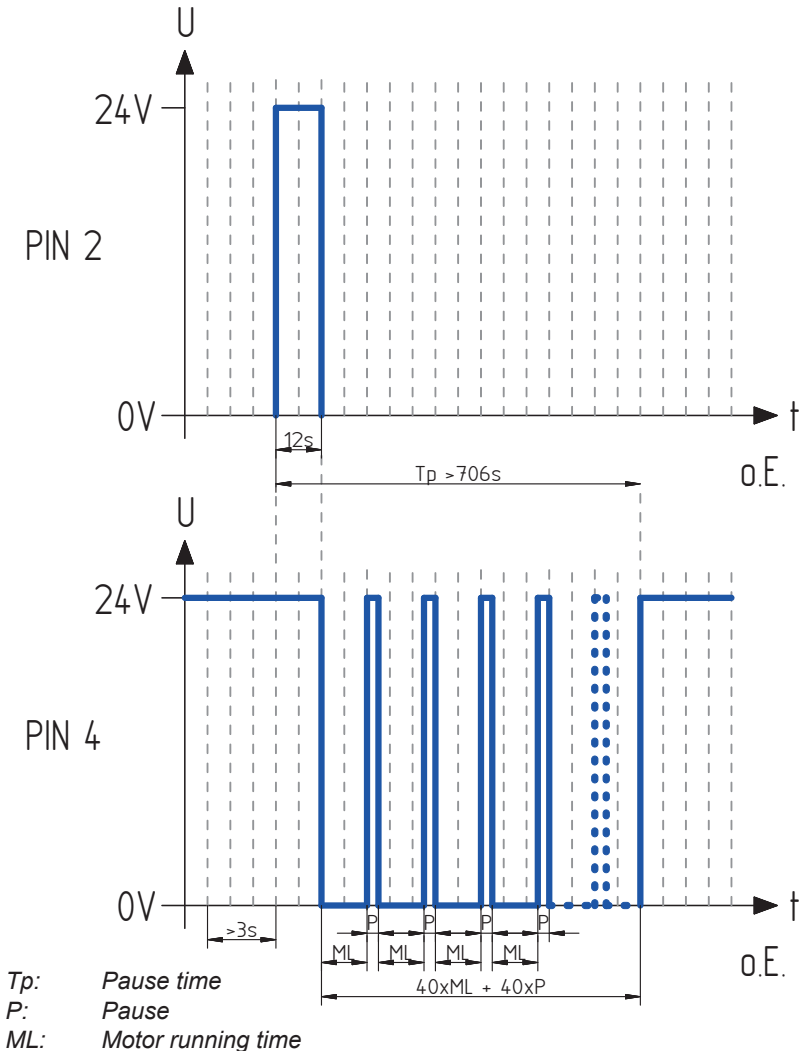

## Description:

✓LUB-D is properly connected to an external controller via the electrical interface and connected to the power supply.

✦ LUB-D sends a permanent output signal (high level) to PIN 4 which indicates to the external control (PLC) that it is ready for operation. This output signal must be permanently and continuously present for >3 seconds. This condition must be fulfilled to control LUB-D by a PLC.

✦ The control signal 12 seconds with a signal length of 12 (11.9 ... 12.1) seconds high level can be sent to LUB-D from the external control (PLC).

✦ Immediately after the control signal drops the motor run (ML) of LUB-D starts and 0.16 cm<sup>3</sup> lubricant is conveyed to the outlet. Simultaneously, LUB-D sends a low level output signal to the external controller (PLC) to confirm the duration of the motor run (ML).

✦ The motor running time (ML) depends on various conditions, including the present or built up counterpressure in the hydraulic system and the temperature. The motor running time (ML) is 7...17 seconds.

✦ At the end of an error-free and successful motor run (ML) the output signal at LUB-D changes from a low level to a high level for a short pause time P = 0.5 seconds.

✦ A total of 40 engine runs and dispenses will take place immediately one after the other.  $40 \times 0.16 \text{ cm}^3 = 6.4 \text{ cm}^3$  lubricant is conveyed from the cartridge to the outlet.

ⓘ A new control signal can be sent from the external controller (PLC) at the earliest of >3 seconds after the motor run ended error-free and successfully. In the meantime, LUB-D does not process any control signals.

ⓘ In order to ensure a reliable and unambiguous recognition of the control signal a pause must be observed. The control signal 12 seconds requires a pause time (Tp) of at least 706 seconds between two identical or different control signals.

ⓘ At a LUB-D version with two pump units 40 filling strokes **per pump unit** are triggered when the control signal is triggered for 12 seconds. The pause time (Tp) is doubled.

ⓘ If the integrated microelectronics of LUB-D have detected an error during or immediately after the motor run (ML), this is transmitted to the external controller (PLC) by the corresponding output signal (chap. 8.3).

## 8.2.5 Control signal 14 seconds

The control signal 14 seconds is used to acknowledge error messages. It is the only control signal that LUB-D can process when a low level output signal is sent. Regardless of the basic principle of remotely acknowledging an error it is essential to identify and eliminate the cause when an error message is present.

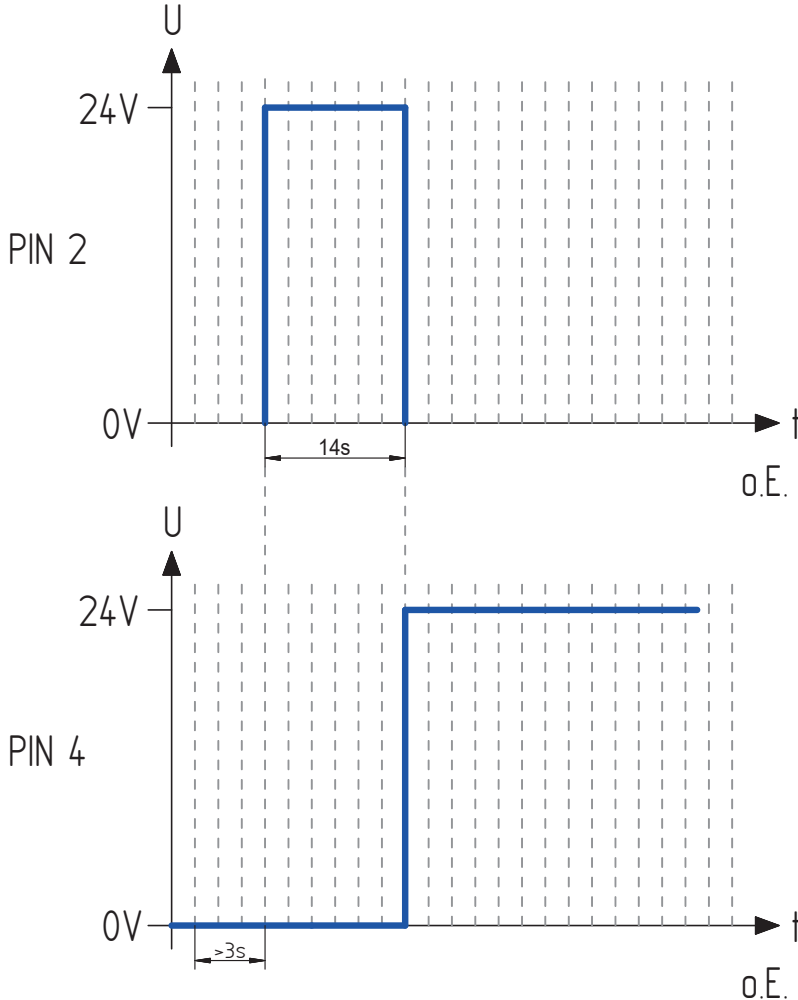

## Description:

✓LUB-D is properly connected to an external controller via the electrical interface and connected to the power supply.

✓There is an error at LUB-D.

✦ LUB-D sends a permanent output signal (high level) to PIN 4 which indicates to the external control (PLC) that it is ready for operation. This output signal must be permanently and continuously present for >3 seconds to control LUB-D by a PLC.

✦ The control signal 14 seconds with a signal length of 14 (13.9 ... 14.1) seconds high level can be sent to LUB-D from the external control (PLC).

✦ When the control signal ends the integrated microelectronics of LUB-D will automatically check itself:

+ If this internal check is **successful**, the output signal at LUB-D changes from a low level to a high level; the error is thus acknowledged and LUB-D is ready for operation again. The LCD briefly displays CLR and then PUL.

- If this internal check is **not successful**, LUB-D continues to send a low level output signal. The error is still present. For further measures in this case: chap. 8.3.4.

ⓘ A new control signal can be sent from the external controller (PLC) at the earliest of >3 seconds after the motor run ended error-free and successfully. In the meantime, LUB-D does not process any control signals.

ⓘ Regardless of the basic principle of remotely acknowledging an error, it is essential to identify and eliminate the cause when an error message is occurs.

## 8.3 Output signals

Output signal (PIN 4)	Description	Chapter
high, permanent	ready for operation	8
high, permanent	received control signal	8
low, 7...17 seconds	dispensing process	8
0.5Hz square wave signal, permanent	cartridge empty	8.3.1
low, permanent	error	

If an output signal as low level (0V) is permanently present at PIN 4 for longer than 3s and no dispensing process is currently being performed by LUB-D, there is an error at LUB-D. The signals only inform about the fact that an error occurred, the cause must be determined and eliminated by the operator. Chapters 8.3.2, 8.3.3 and 8.3.4 provide a procedure and possible causes for error messages.

## 8.3.1 Empty level (E1)

LUB-D is equipped with a sensor which detects the empty level of the lubricant cartridge. After reaching the empty level, LUB-D no longer dispenses lubricant. This ensures that no air enters LUB-D or the lubricant lines. The empty state message (E1) is transmitted to the external control (PLC). For this purpose, a separate, unique output signal is provided which can be easily and reliably detected by the external control (PLC).

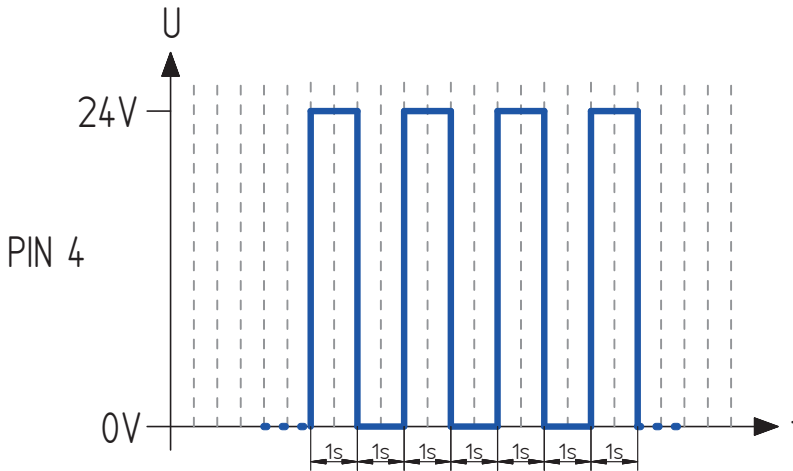

### Description:

✓ LUB-D is properly connected to an external controller via the electrical interface and connected to the power supply.

- ✦ The empty state signal can only occur immediately after a dispense.
- ✦ The empty state signal must not and cannot be acknowledged. Remedial action is described in chapter 9.2.

ⓘ LUB-D does not process any control signals until all errors have been eliminated.

The transition of the output signals when changing a cartridge on LUB-D in switched-on state is shown and described below:

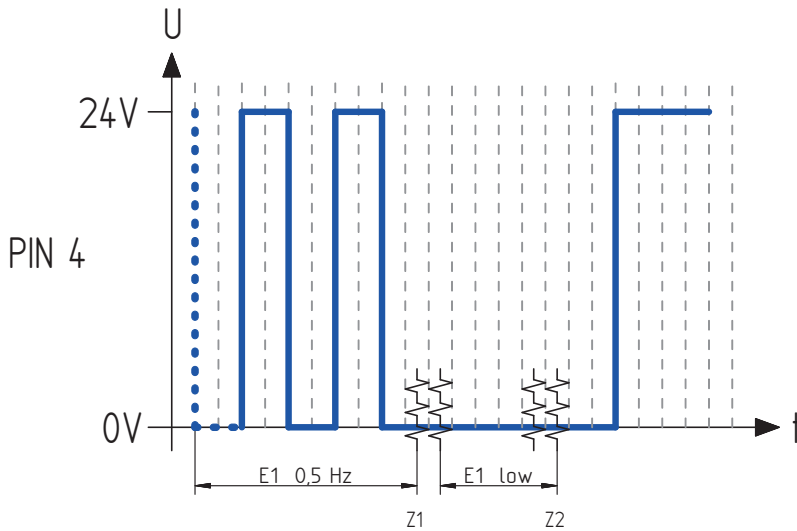

- Z1: *Removing the empty cartridge*  
 Z2: *Mounting the new cartridge*

### Description:

✓ LUB-D is properly connected to an external controller via the electrical interface and connected to the power supply.

- ✦ The empty cartridge is detected after a dispense, the output signal of LUB-D is initially a 0.5Hz square wave signal (empty state signal) (0/+24 V).
- ✦ Z1 indicates the period of removing the empty cartridge. The output signal of LUB-D now changes from a 0.5Hz square wave signal to a permanent low signal (0V).
- ✦ Z2 indicates the period of screwing on a new, full cartridge. The output signal of LUB-D now changes from a permanent low signal (0V) to a permanent high signal (+24V). In this way LUB-D signals to the external controller (PLC) that it is ready for operation again.
- ✦ If the empty state signal has occurred during the execution of the control signal 12 seconds the outstanding strokes are continued after the new cartridge has been screwed on.

ⓘ LUB-D does not process any control signals until all errors have been eliminated.

## 8.3.2 Error: overload (E2)

Error "overload" (E2) signals a hydraulic overload during a dispensing process, e.g. if the maximum pressure is exceeded.

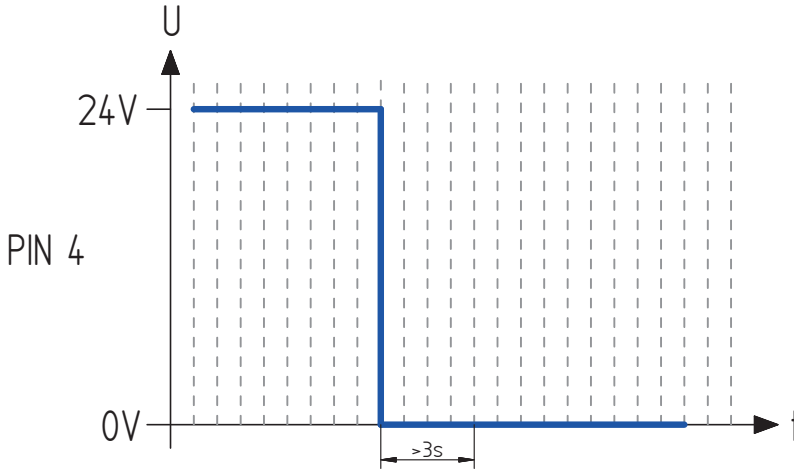

### Description:

✓LUB-D is properly connected to an external controller via the electrical interface and connected to the power supply.

✓LUB-D has been successfully controlled by the external control (PLC) immediately before the occurrence of error E2 and has (attempted to) perform a dispensing operation.

✦ When the maximum permissible pressure is reached during or after a dispense, LUB-D sends a permanent output signal as low level (0 V) to PIN 4 for external control (PLC).

✦ Check the connection lines to the lubrication points and eliminate the causes.

✦ The error "overload" must be acknowledged with the control signal 14 seconds (chapter 8.2.5) after elimination of the cause(s).

ⓘ LUB-D does not process any control signals until all errors have been eliminated.



## 8.3.3 Error: undervoltage (E3)

Error "undervoltage/overvoltage" (E3) indicates that the power supply is not within the specified parameters.

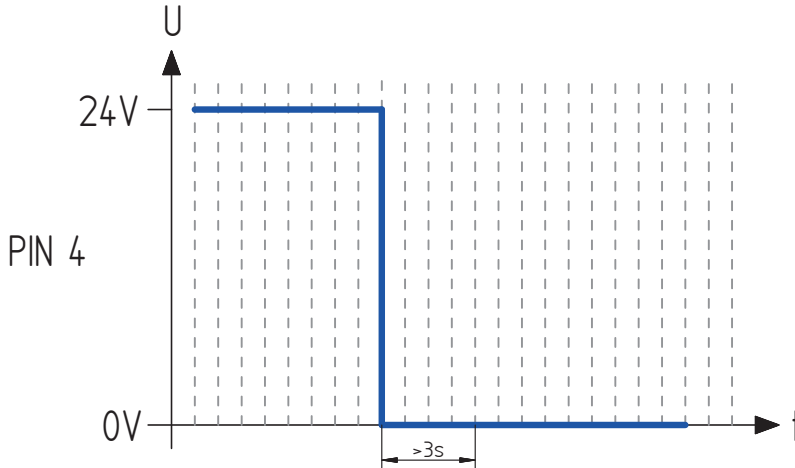

### Description:

✓LUB-D is properly connected to an external controller via the electrical interface and connected to the power supply.

- ✦ If the supply voltage is too low, LUB-D sends a permanent output signal as low level (0 V) to PIN 4 for external control (PLC).
- ✦ Check the supply voltage and compare it with the parameters given in the technical data sheet.
- ✦ Error E3 (undervoltage) must be acknowledged with the control signal 14 seconds (chapter 8.2.3) after elimination of the cause(s).

ⓘ LUB-D does not process any control signals until all errors have been eliminated.

## 8.3.4 Fatal error (E4)

A "fatal error" (E4) indicates that the integrated microelectronics has detected a critical error and that LUB-D is not operating within the valid parameters. The cause can be mechanical, electronic or any other influencing variable.

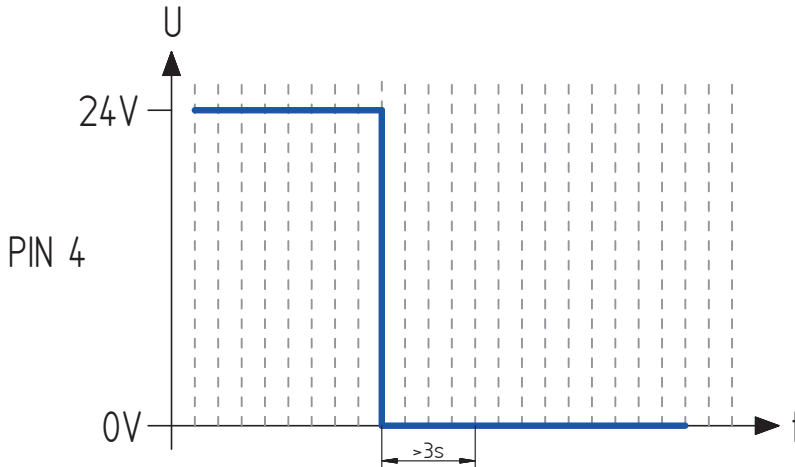

### Description:

✓ LUB-D is properly connected to an external controller via the electrical interface and connected to the power supply.

- ✦ In an (internal) diagnosis, the critical (rare) error E4 has been detected.
- ✦ Error E4 cannot be corrected by you on site and cannot be acknowledged by you on LUB-D!
- ✦ Remove LUB-D with the lubricant cartridge screwed on and return the complete lubrication system to the manufacturer with a detailed description of the fault.

ⓘ Do not open LUB-D without authorization! Observe the relevant notes and regulations for proper use (section 2.5) and warranty (section 2.6).

## 9. Maintenance and disposal

- ✦ Before starting any maintenance work, inform yourself about the general safety instructions (see chapter 2) and observe the relevant local and operational safety regulations.
- ✦ Do not deactivate any protective device without authorization!

### 9.1 Maintenance schedule

The following maintenance schedule must be observed for LUB-D:

Maintenance	Commissioning	After 500 hours or after 3 months	Annually	If required
Cleaning	X	X	X	X*
Visual check	X	X	X	X*
Cartridge change	X**		X***	X*

\* Depending on operating conditions and lubricant consumption

\*\* Depending on delivery status (ordered version)

\*\*\* after 2 years at the latest

## 9.1.1 Visual check

- ✦ Check the entire lubrication system (LUB-D and any connected accessories including tubes and distributors) for external damage (e.g. loose or loosened tubes) by a thorough and conscientious visual inspection.
- ✦ Check the condition of the lubrication point for correct supply of lubricant.
- ✦ Replace damaged or defective parts immediately to ensure permanent lubrication.
- ✦ Check the filling level of the cartridge on LUB-D.
- ✦ Check possible error messages on LUB-D and remedy the causes accordingly.

## 9.1.2 Cleaning

- ✦ Clean LUB-D from dirt using suitable cleaning agents (e.g. absorbent towels, cloths).

	<b>NOTICE</b>
	<p><b>Compressed air can damage the seals of LUB-D as well as transport dirt and foreign bodies into LUB-D or the lubricant.</b></p> <ul style="list-style-type: none"><li>• Do not use compressed air to clean LUB-D.</li></ul>

## 9.1.3 Recommissioning after maintenance

- ✦ Reinstall all safety devices and make sure that no tools remain in the danger area.
- ✦ Check if LUB-D is switched on.
- ✦ After a long standstill of LUB-D a manually triggered single dispense is recommended. Please use the 2 seconds signal or 8 seconds signal depending on your model (chap. 8.2.1 and 8.2.3)..

## 9.2 Cartridge change

	NOTICE
	<p><b>A used lubricant cartridge must not be replaced on LUB-D as the integrated stroke counter of LUB-D is automatically reset by the cartridge sensor after a cartridge has been removed.</b></p> <ul style="list-style-type: none"> <li>• Only use full lubricant cartridges.</li> </ul>

	NOTICE
	<p><b>Only use original lubricant cartridges with lubricant approved by the manufacturer.</b></p> <ul style="list-style-type: none"> <li>• Observe the maximum shelf life of lubricant filled in cartridges.</li> </ul>

	NOTICE
	<p><b>It is not possible to refill empty or opened lubricant cartridges.</b></p>

	NOTICE
	<p><b>Make sure you use the same lubricant in the new cartridge that is already in use.</b></p> <ul style="list-style-type: none"> <li>• Compare the data on the lubricant cartridge.</li> </ul>

✓The cartridge is empty.

Changing the lubricant cartridge of LUB-D is very easy.

The cartridge needs to be changed if it is empty or if the service life of the lubricant has been exceeded. The cartridge can be changed during normal operation of LUB-D. Besides the cartridge change no further action is needed.

1

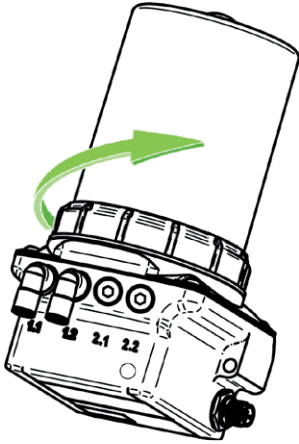

## Remove housing from power unit

✦ Separate the housing from the power unit by turning the retaining ring counterclockwise.

ⓘ Make sure that no dirt, water or foreign bodies enter the lubricant inlet.

2

## Remove empty cartridge

✦ Turn the empty cartridge clockwise to remove it.

3

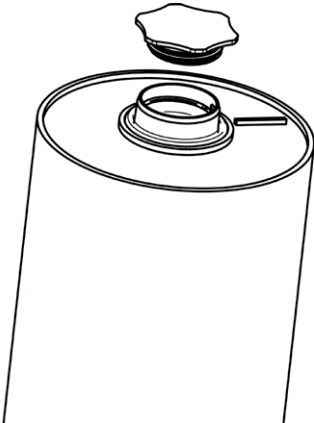

## Remove cartridge cap

✦ Turn the cap of the lubricant cartridge counterclockwise and pull it off.

ⓘ Pay attention to cleanliness when carrying out the work. Be sure to prevent dirt, liquids and foreign bodies from entering the cartridge.

4

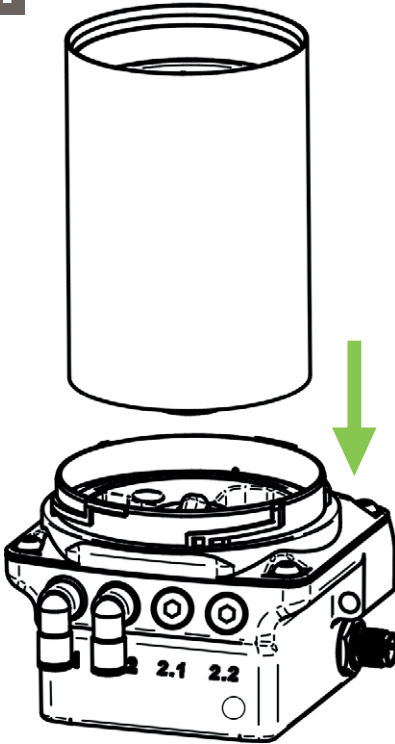

## Mount new lubricant cartridge

- ✦ Place the full lubricant cartridge onto LUB-D (label facing front).
- ✦ Turn the lubricant cartridge clockwise onto LUB-D.

ⓘ The end position is reached after two full rotations when the label of the lubricant cartridge is aligned with the front label of LUB-D.

5

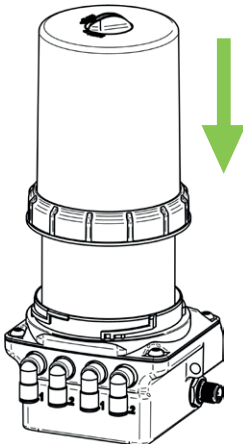

## Assemble housing on power unit

- ✦ Place the dismantled housing on LUB-D and press it onto the power unit.
- ✦ Fasten the housing to the power unit by turning the retaining ring clockwise.

ⓘ The retaining ring must snap into place when turning and be completely tightened.

✦ Carry out the work as described above.

① If the empty state of the cartridge (error E1) was reached during a dispensing cycle, it is interrupted and continued automatically after completing the work explained above.

## 9.3 Disposal

✦ When disposing LUB-D and empty or opened cartridges follow the relevant national regulations in force.

✦ When disposing LUB-D observe the relevant safety data sheets and disposal instructions for the individual components.

① It is not possible to refill empty lubricant cartridges.



### 3. Released accessories

The present LUB-D can be considerably extended from use as a single point lubricator by the extensive system and accessory program. This may necessitate changes to the factory and/or the default settings of LUB-D to ensure reliable and proper operation of LUB-D combined with the hydraulically connected accessories.

Amongst others, cartridges filled with different lubricants, brackets, splitters and progressive distributors are available.

For more information please contact the manufacturer or visit its website [www.G-LUBE.com](http://www.G-LUBE.com).

## 10.1 Lubricants

Only use lubricants approved by Gruetzner GmbH in the original cartridges developed and manufactured exclusively for LUB-D.

	<b>NOTICE</b>
	<b>The lubricant used in each case differs according to the application. The respective designation can be found on the label of the cartridge.</b>

Further information on lubricants, documentation and safety data sheets can be obtained directly from Gruetzner GmbH.

## 10.2 Tube lengths

Generally it is recommended to install LUB-D as close as possible to the consumer (lubrication point). Ideally, this should be done directly at or on the lubrication point. In cases where this is not possible due to the installation space or for reasons of reachability or accessibility, tubes can also be used between LUB-D and the lubrication point (or distributor).

The tube length shall not exceed 5 meters, the inner tube diameter shall not be lower than 4 mm. The maximum tube length depends on a wide range of parameters such as temperature, application and viscosity of the lubricant used.

## 4. Appendix 4.1 Dimension sheet and installation dimensions

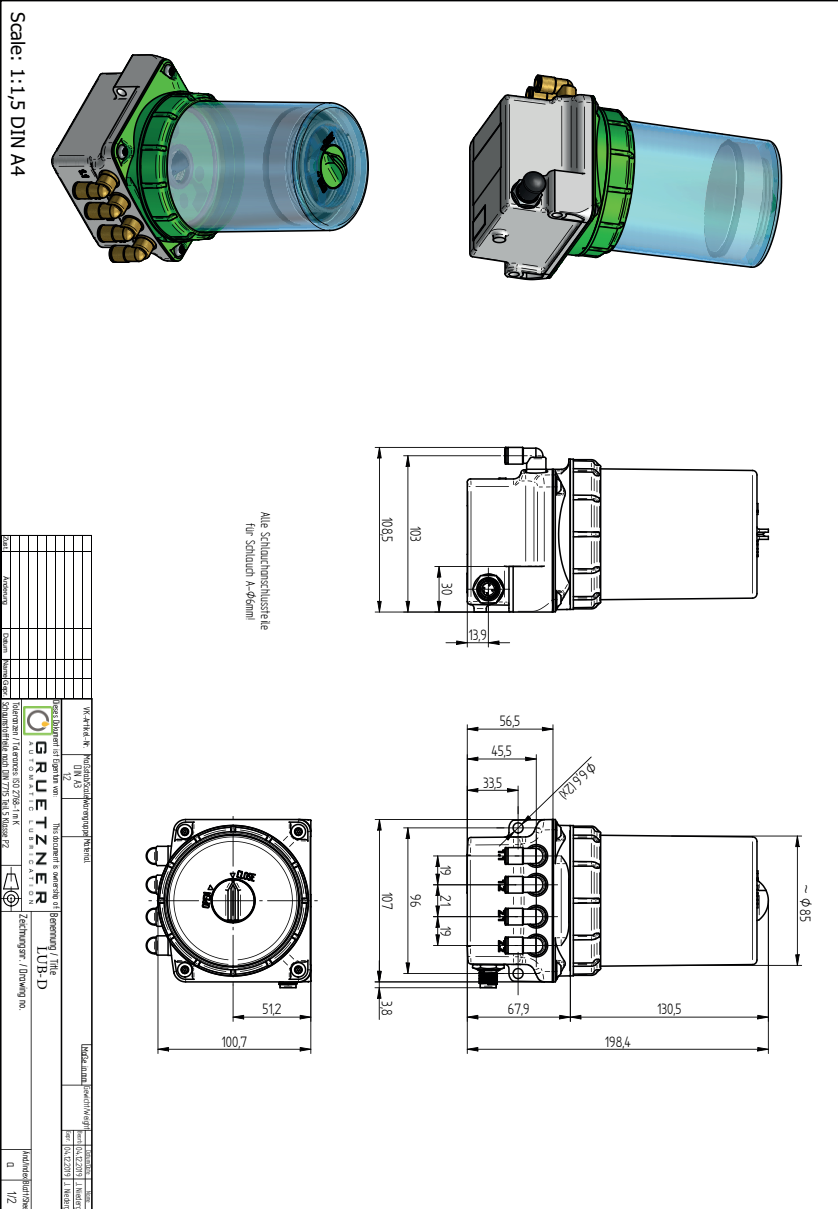

## 4.2 EC/EU Declaration of conformity

### EC declaration of conformity



**Declaration of conformity  
according to EC machinery directive 2006/42/EC as of 17. May 2006**

The manufacturer or authorised representative\*

**Gruetzner GmbH, Kohlenhofstr. 60, 90443 Nuremberg, Germany**

hereby declares that the following lubrication systems

**Product designation: LUB-D**  
**Type designation: LUB-D-1, LUB-D-2, LUB-D-3, LUB-D-4, LUB-D-1-1**

comply with the essential requires of EC directive 2006/42/EC.

The following harmonized standards have been applied:

EN 12100:2011 Saftey of machines

Additionally the systems comply with the regulations for electromagnetic compability according to 2004/108/EC.

The following harmonized standards have been applied:

EN 61000-6-2, EN 61000-6-4 electromagnetic compability

Authorised representative for the compilation of technical documents:

Volker Grütznér, CEO, Gruetzner GmbH, Kohlenhofstr. 60, 90443 Nuremberg, Germany

Nuremberg, 01.06.2015

Volker Grütznér, CEO

\*must be based within the EU

**Gruetzner GmbH**

Kohlenhofstr. 60

90443 Nuremberg, Germany

Tel: +49 911 277399-0

Fax: +49 911 277399-99

info@G-LUBE.com

www.G-LUBE.com



**GRUETZNER**  
AUTOMATIC LUBRICATION



## 4.3 Spare parts

Art. no.	Designation	Application

## 4.4 Flow chart impulse mode PUL

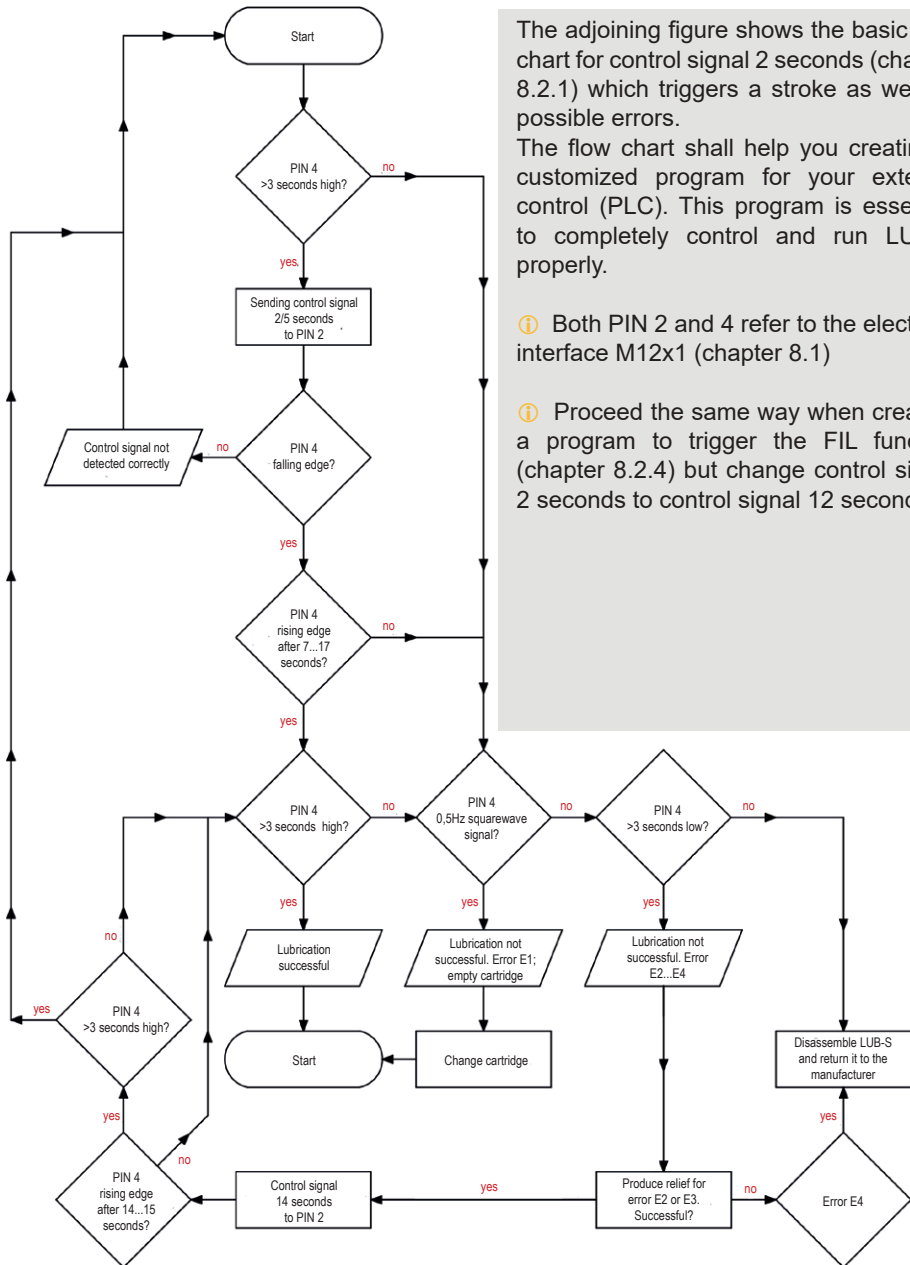

The adjoining figure shows the basic flow chart for control signal 2 seconds (chapter 8.2.1) which triggers a stroke as well as possible errors.

The flow chart shall help you creating a customized program for your external control (PLC). This program is essential to completely control and run LUB-D properly.

**i** Both PIN 2 and 4 refer to the electrical interface M12x1 (chapter 8.1)

**i** Proceed the same way when creating a program to trigger the FIL function (chapter 8.2.4) but change control signal 2 seconds to control signal 12 seconds.



**GRUETZNER**  
AUTOMATIC LUBRICATION



**G LUBE**



**SOLO LUBE**

**AUTOMATIC LUBRICATION**



**LUB 5**



**LUBRICUS**

**Gruetzner GmbH**

Kohlenhofstr. 60 • D - 90443 Nuremberg, Germany  
info@G-LUBE.com • www.G-LUBE.com