

Dear customer,

Congratulations!

You have chosen the best product we know how to make with our 30 years of experience and passion for precision.

Please follow the instructions in this manual to avoid mistakes and save time.

In case you need further information or you have further requests we will be glad to be at your disposal.

With best regards,

Your GRIP GmbH

GRIP GmbH Handhabungstechnik  
Alter Hellweg 70  
44379 Dortmund, Germany

Tel. +49 231 96450 01

info@grip-gmbh.com  
www.grip-gmbh.com

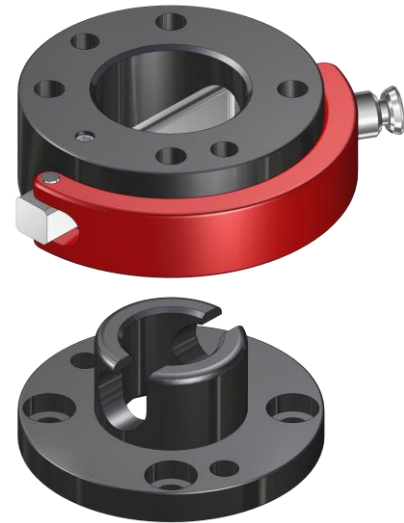

## MGW Connector

	<b>Contents</b>	<b>Page</b>
<b>1</b>	Operation	2
<b>2</b>	Safety	2
	<b>2.1</b> Symbol	2
	<b>2.2</b> Intended use	2
	<b>2.3</b> Environmental and operating conditions	2
	<b>2.4</b> Safety indication	2
<b>3</b>	Warranty	3
<b>4</b>	Scope of delivery	3
<b>5</b>	Technical data	3
<b>6</b>	Assembly	4
<b>7</b>	Maintenance and care	5
	<b>7.1</b> Disassembly	5
	<b>7.2</b> Torque specifications	5
<b>8</b>	Parts list	6
	<b>8.1</b> Spare and wear parts	6
<b>9</b>	Exploded view	7
<b>10</b>	EC-Declaration of incorporation	8

## 1 Operation

To open the change system, pull the locking pin on the hand lever. After that the hand lever is to be opened by approximately 90°. With the help of the hand lever the semi-cylindrical bolt can be turned counter clockwise ("to the left") by 180° up to the stop. The upper and lower assembly can now be pulled apart. When joining the parts, the hand lever must be set to open position. It cannot lock in this position. Now, upper and lower assembly can be pushed into each other. By turning the semi-cylindrical bolt clockwise ("to the right") 180° up to the stop, the system is locked. Afterwards the hand lever is folded and latched.

## 2 Safety

### 2.1 Symbol



This symbol indicates possible hazards to persons or the MGW Connector.

### 2.2 Intended use

The MGW Connector has been designed as an interface between handling device and tool (e.g. gripper). Furthermore, the MGW can also be used in special solutions, automation and also as a general mechanical standard interface. The unit may only be used in the context of its technical specifications. The system is intended for the installation in a machine. The requirements of the applicable instructions must be considered and adhered to.

### 2.3 Environmental and operating conditions

Use this unit only in dry and splash-proof environments at room temperature as well as within the application parameters defined in the technical specifications. If this is not the case, warranty cannot be accepted. Exceptions are units designed especially for the respective conditions.

### 2.4 Safety indication

Dangers may arise from the unit, if:

- the product is not installed or inserted properly,
- the system is not used for its intended purpose,
- the safety and installation notes are not observed.

Everyone who is responsible for assembly, commissioning and maintenance must read and understand the complete operating instructions. Improper use, which affects the function and operational safety of the MGW Connector, is prohibited.

#### **CAUTION! Never operate the hand lever when the load is suspended!**



In order to prevent damage to the connector as well as injuries to the operator, the lower assembly or the tool must be secured by hand or other devices before opening the exchange system. Otherwise there is a risk that irreparable damages to the tool or injury to the operator are caused by the unit falling down.



#### **NOTICE!**

The unit may only be operated if the machine in which the unit is installed complies with the relevant provisions of the machinery directive 2006/42/EC.

### **3 Warranty**

If the product is used as intended in 1-shift operation the warranty is valid for 24 months from the ex-works delivery date under observance the mandatory maintenance and lubrication intervals and the given operating conditions. Generally parts touching the work piece and wear parts are not part of the warranty. Wear parts are listed in chapter 8.1. The unit is considered to be defective if its basic function "Lock" is no longer functioning.

### **4 Scope of Delivery**

- MGW as shown in Image 6 depending on the order number of the upper or lower assembly.

### **5 Technical Data**

Behold technical data sheets: TD-MGW050-EN, TD-MGW063-EN, TD-MGW080-EN, TD-MGW100-EN, TD-MGW125-EN, TD-MGW160-EN

**6 Assembly**

The upper assembly of the MGW Connector is mounted on the robot flange, the manipulator or similar actuators. It can be centered with the help of a centering disc. The angular orientation is determined by means of a fitting bore. The lower assembly is mounted on grippers, measuring instruments or other tools. If the MGW Connector can not be installed directly, adapter flanges must be used. Use screws according to ISO 4762 during mounting. For the sizes 50, 63 and 80, screws according to DIN 7984 are to be used on the gripper side. The screw-in depth of the screws must be observed. We recommend the use of a "medium-tight" screw lock.

There is a fitting bore available for the angular orientation for sizes MGW050 to MGW080. For the installation sizes MGW100 to MGW160 there are two fitting bores on the flange surfaces. These are designed according to ISO 9409.

Optionally, the MGW can be provided with a MEK Energy Coupling. To mount the MEK the "E" option must be specified when ordering the MGW. The MEK is available in different versions. The MEK enables the simultaneous coupling of electrical and pneumatic feedthroughs. The MEK is mounted with two cylinder screws to the upper and lower assemblies. For further installation instructions, please refer to the assembly and operating instructions of the MEK.



**CAUTION!**

**Perform assembly work only when the power supply is switched off!**



**CAUTION! Risk of pinching the fingers when closing the MGW**

When assembling, the upper and lower assemblies do not have to be inserted into each other as far as they will go. The upper assembly is able to pull the bottom approx. 1/12 of the external diameter. That means a change system with the installation size 160 is capable of using the lower assembly 160/12 ~ 13mm.

See also the demo video at [www.grip-gmbh.com](http://www.grip-gmbh.com)

**Image 1**

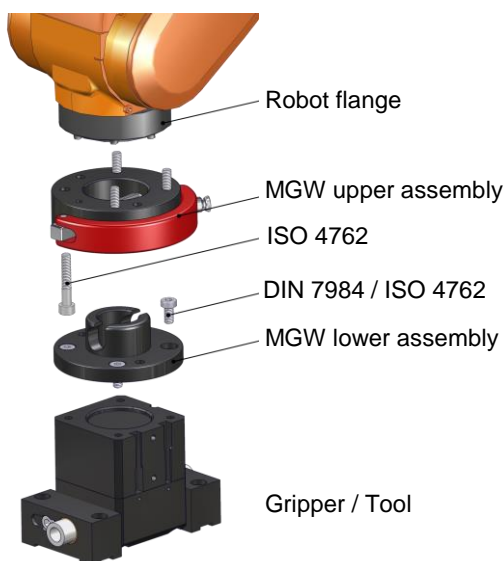

**Image 2**



## Centering disc

In order to achieve a precise fit, centering discs in every size are offered (as shown in image 3).

The use of a centering disc ensures that the upper assembly and/or lower assembly of the Connector are properly centered. Installation on both the upper assembly and lower assembly is possible (as shown in image 4).

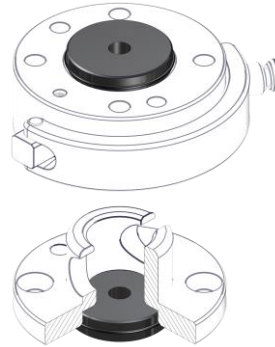
**Image 3****Image 4**

## 7 Maintenance and care

The MGW is virtually maintenance-free. Check the semi-cylindrical bolt in regular intervals for correct function. Keep the mating surface and the moving parts clean and lubricate them slightly. Spare parts and component parts of the MGW can be found on our homepage: [www.grip-gmbh.com](http://www.grip-gmbh.com)

### 7.1 Disassembly of the MGWs

(Behold Image 5)

1. Disassemble the MGW.
2. Loosen the Setscrew (Pos. 7).
3. Disassemble the semi-cylindrical bolt (Pos. 2) from the other components (Pos. 3, 5 and 6). Remove the cylinder bolt if needed (Pos. 5).
4. Clean all parts thoroughly. Inspect for wear and defects.
5. Lubricate all mating surfaces.

For assembly, reverse the order.

### 7.2 Torque specifications

M6 – 8,5 Nm; M8 – 20,6 Nm; M10 – 41 Nm; M12 – 71 Nm

**8 Parts list**

Pos.	Description	Quantity
1	Upper assembly	1
2	Semi-cylindrical bolt	1
3	Hand lever	1
4	Index pin	1
5	Cylinder bolt	1
6	Spring locking pin	1
7	Setscrew	1
8	Lower assembly	1

**8.1 Spare and wear parts, depending on size**

Pos.	Description	Order-No.
1	Semi-cylindrical bolt	EG-MGW...-HB
2	Semi-cylindrical bolt VA	EG-MGW...-HB-V
3	Hand lever	EG-MGW...-HH

9 Exploded view

Image 5

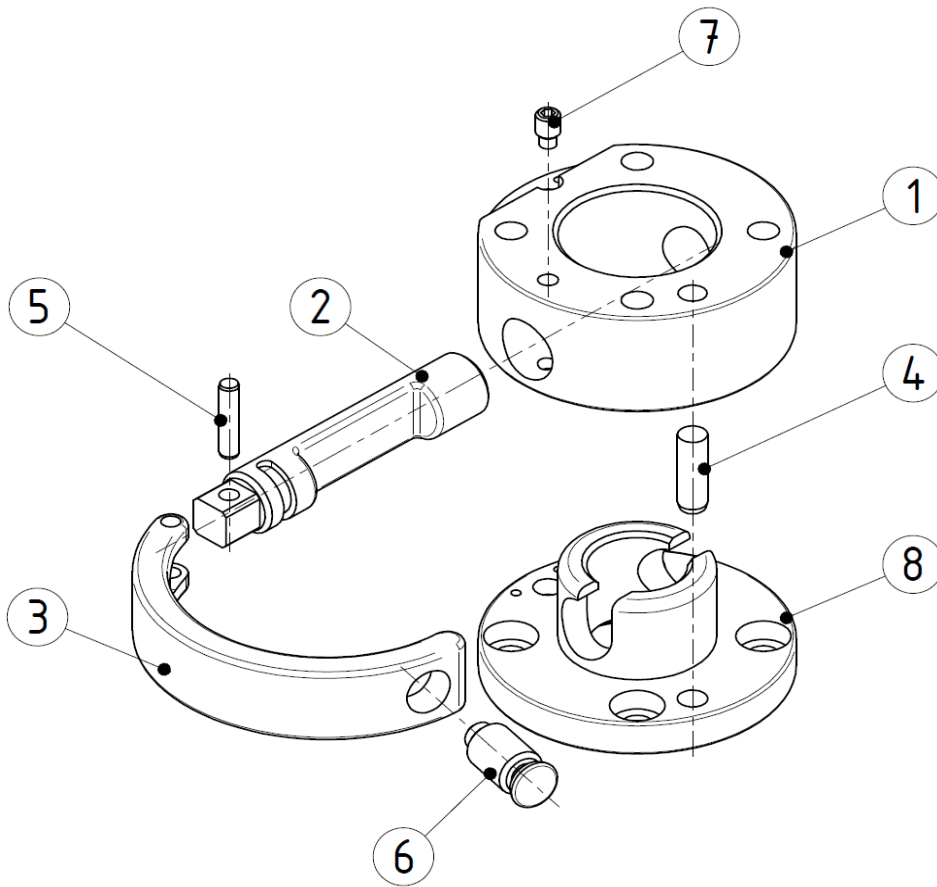
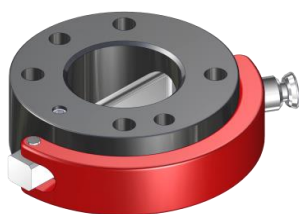

Image 6



Upper assembly



Lower assembly

**10 EC - Declaration of incorporation**

according to the Machinery Directive 2006/42/EC

The producer / distributor GRIP GmbH Handhabungstechnik  
Alter Hellweg 70  
D-44379 Dortmund, Germany

hereby declares that the following products

**Product designation:** Manual gripper change System (MGW)

**Functional description:** Systems for the semi-automatic and form-closed exchange of components such as grippers and tools on robots or receptacles

**Type designation:** G-MGW050 to MGW160

The provisions of the above-mentioned directives -including their effective amendments- comply with the time of the declaration.

He further states that the following essential requirements of the Machinery Directive 2006/42/EC were applied and observed:  
annex I, numerics: 1.1.2; 1.1.3; 1.1.5; 1.3.2; 1.7.4

He further states that the specific technical documentation has been drawn up in accordance with annex VII, Part B.

The following harmonized standard has been applied:

EN ISO 12100:2010 Safety of Machinery- Basic concepts, general principles for design- Part 1:  
Basic terminology and methodology

Safety of Machinery- Basic concepts, general principles for design- Part 2:  
Technical principles

In the case of reasoned requests, the specific documents shall be sent to the national authorities as follows: Post

The product mentioned above may only be put into operation if it has been established applicable that the unit, into which the above-mentioned product is to be incorporated, complies with the provisions of the Machinery Directive 2006/42/EC.

Authorized representative Dipl.-Ing. (FH) Hasan Canti

Location: Dortmund  
Date: 14.09.2022

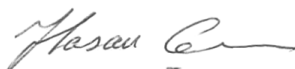

Dipl.-Ing. (FH) Hasan Canti  
Executive Director