

Datum 08.11.2016 Maßstab 1:1

Zeichnungsnummer
G-MGW063-2Z

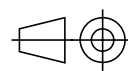

GRIP
GRIP GmbH Handhabungstechnik

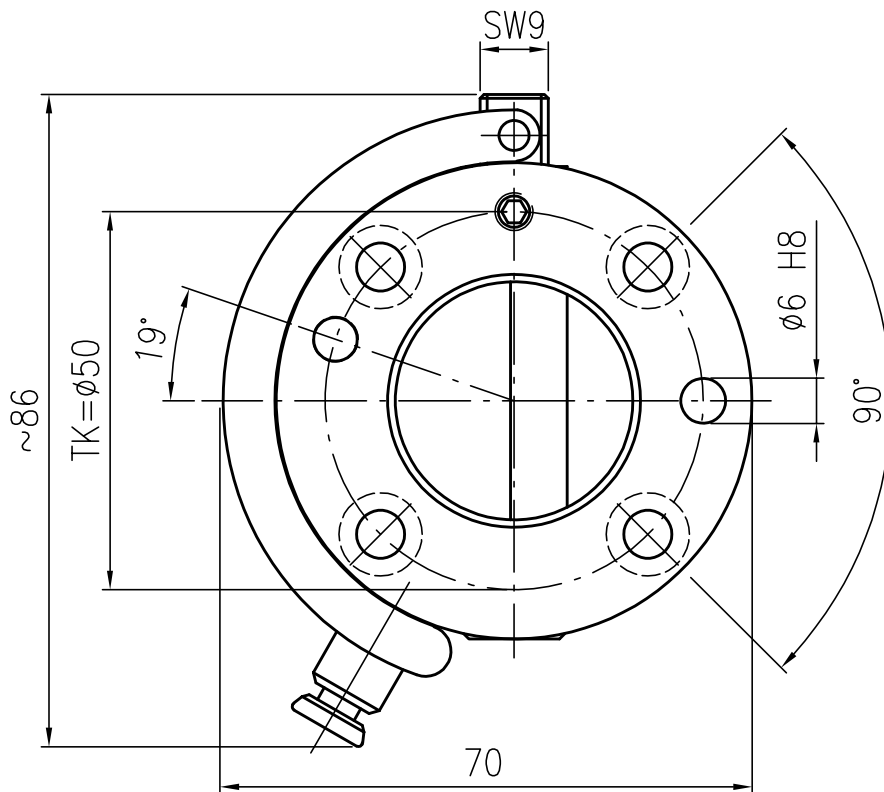
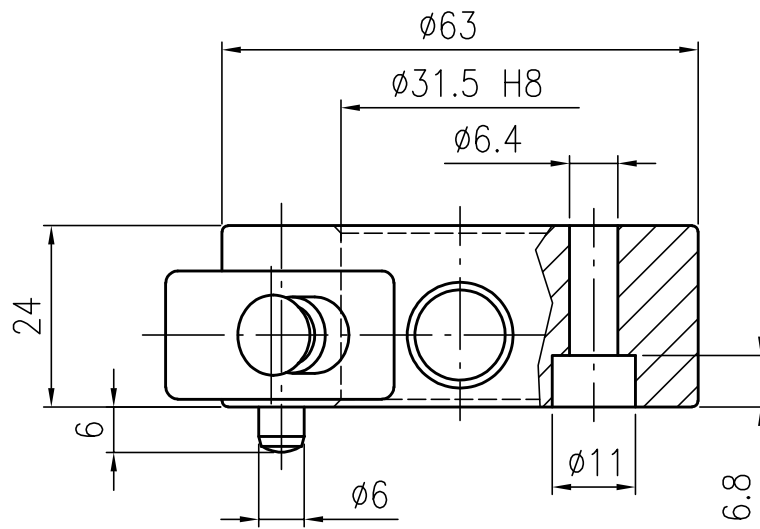

Grundmaterial	Bestellnummer Oberteil
Al. eloxiert	G-MGW063-20
Stahl	G-MGW063-20-S
St. nitriert	G-MGW063-20-N
VA	G-MGW063-20-V

Datum 08.11.2016

Maßstab 1:1

Zeichnungsnummer

G-MGW063-20

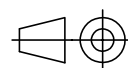

GRIP

GRIP GmbH Handhabungstechnik

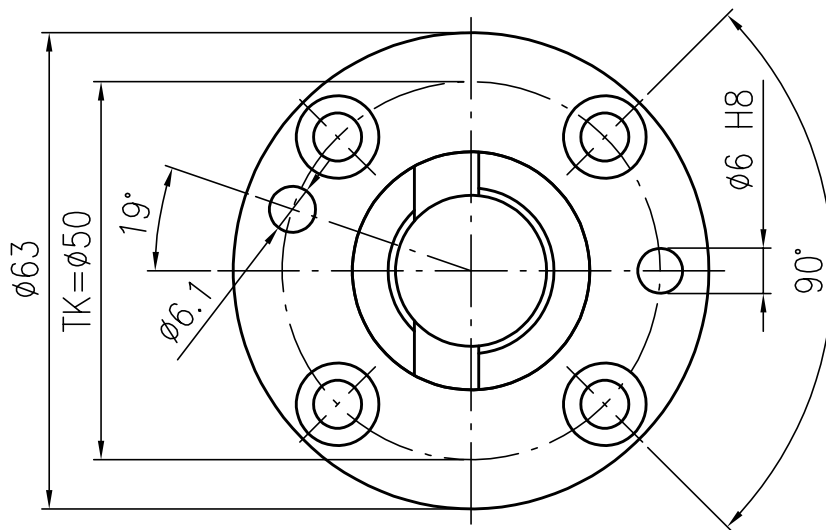
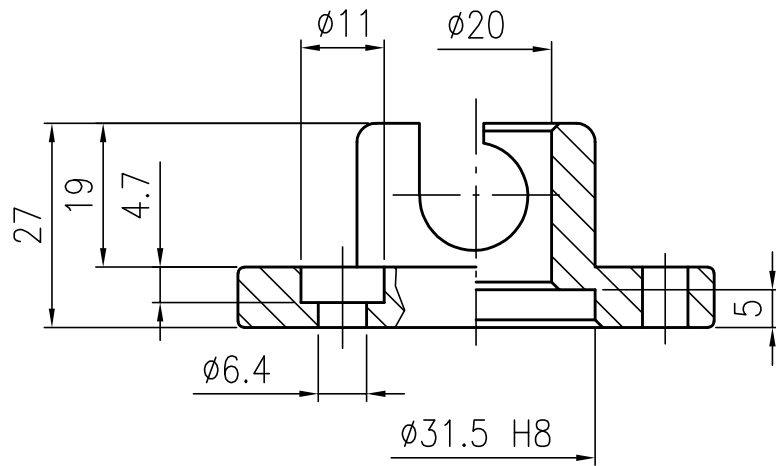

Grundmaterial	Bestellnummer Unterteil
Al. eloxiert	G-MGW063-2U
Stahl	G-MGW063-2U-S
St. nitriert	G-MGW063-2U-N
VA	G-MGW063-2U-V

Datum 08.11.2016

Maßstab 1:1

Zeichnungsnummer

G-MGW063-2U

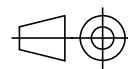

GRIP

GRIP GmbH Handhabungstechnik

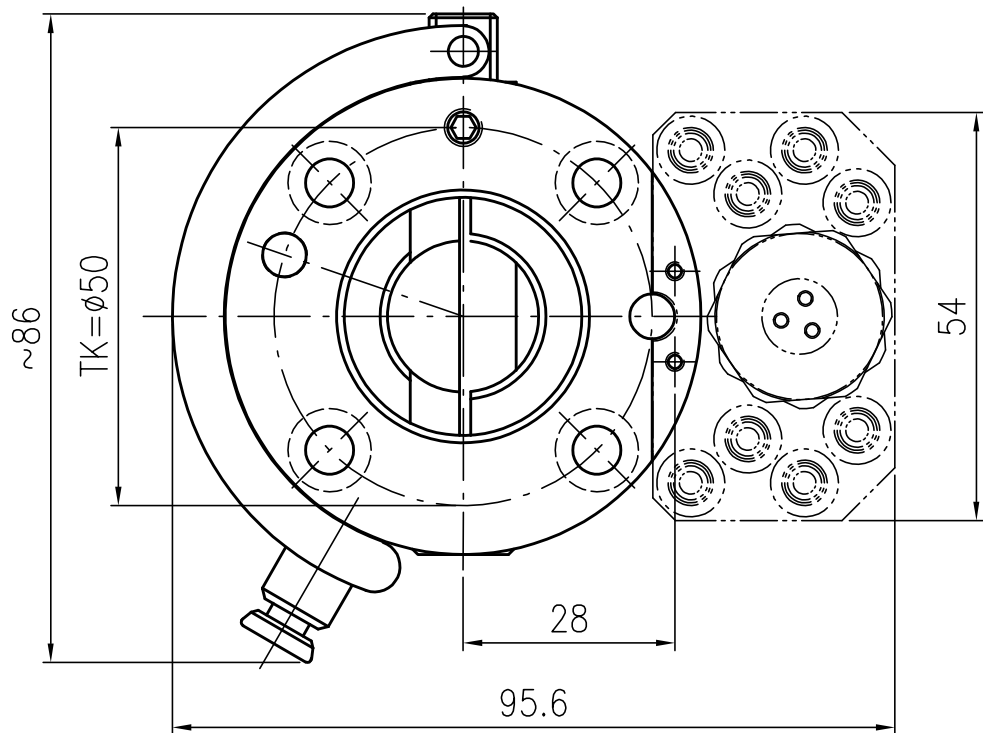
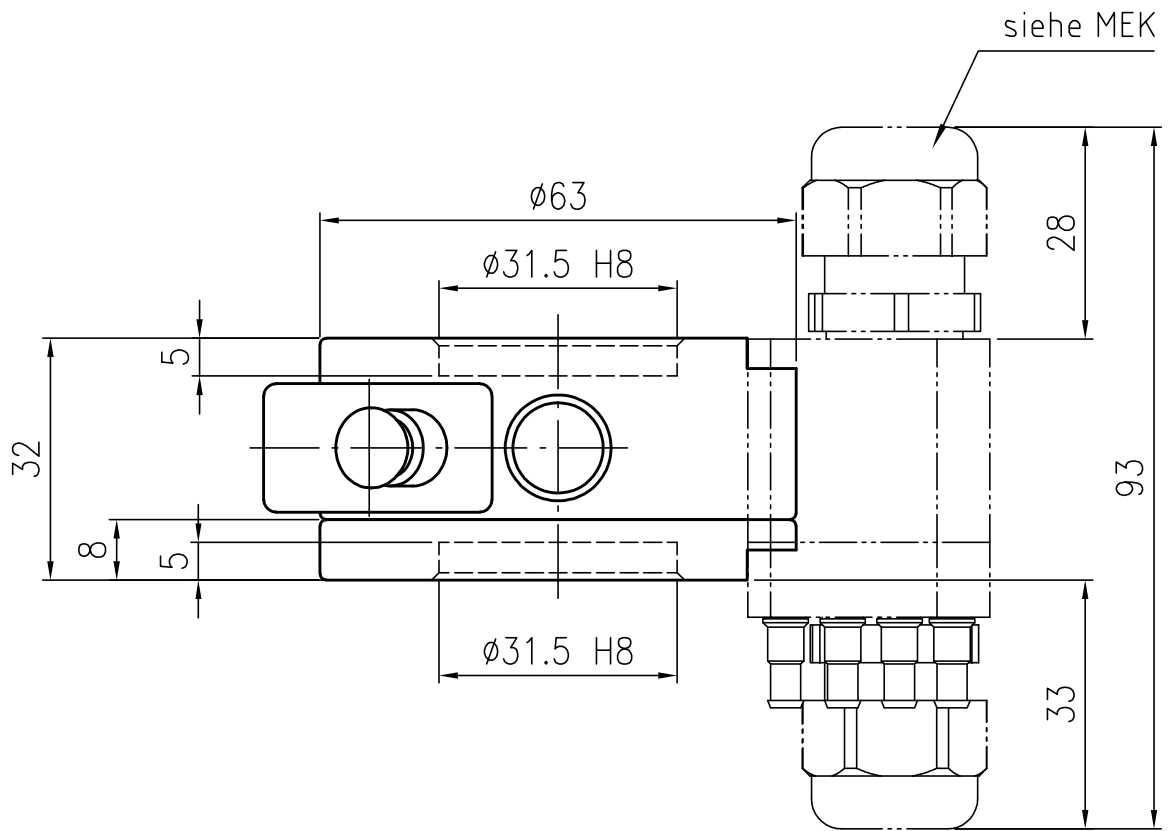

Datum 08.11.2016

Maßstab 1:1

Zeichnungsnummer

G-MGW063-2ZE

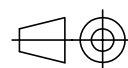

GRIP

GRIP GmbH Handhabungstechnik

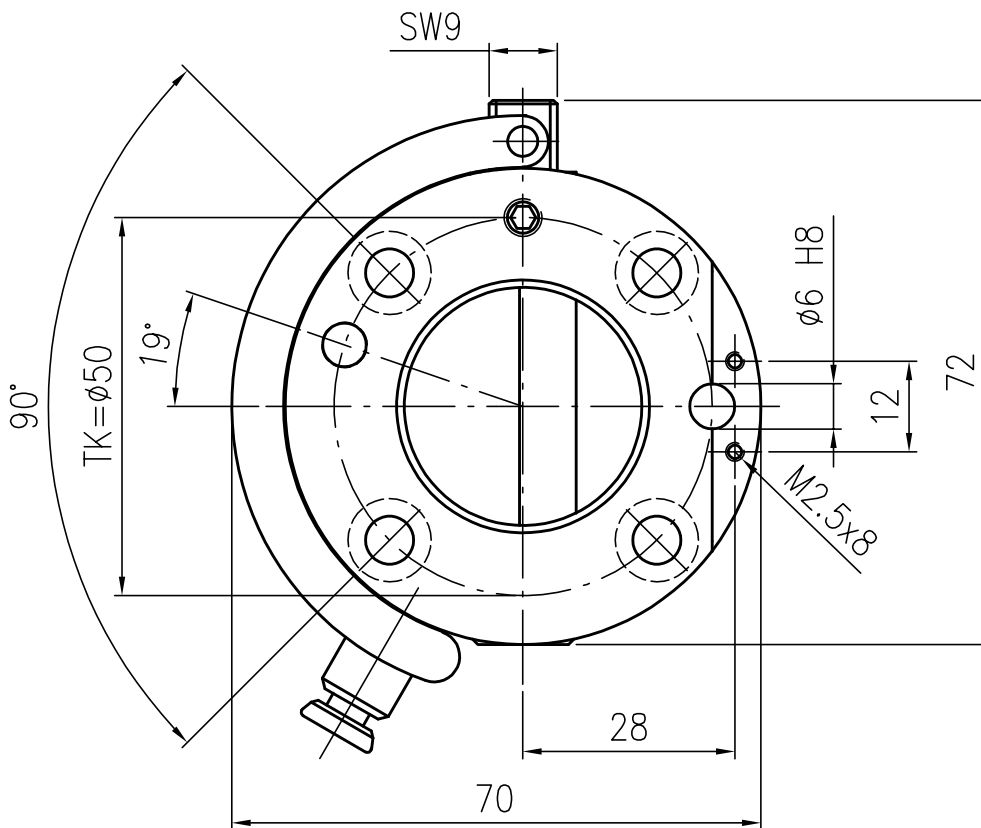
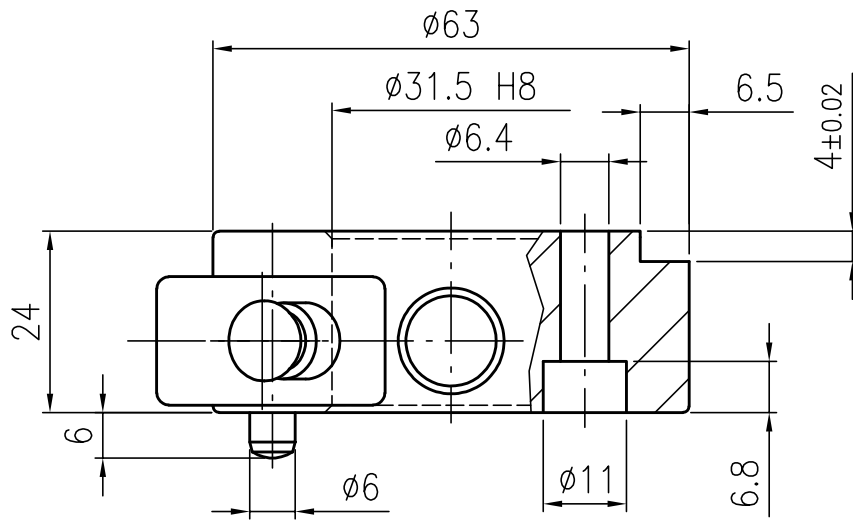

Grundmaterial	Bestellnummer Oberteil
Al. eloxiert	G-MGW063-20E
Stahl	G-MGW063-20ES
St. nitriert	G-MGW063-20EN

Datum 08.11.2016

Maßstab 1:1

Zeichnungsnummer

G-MGW063-20E

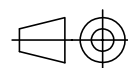

GRIP

GRIP GmbH Handhabungstechnik

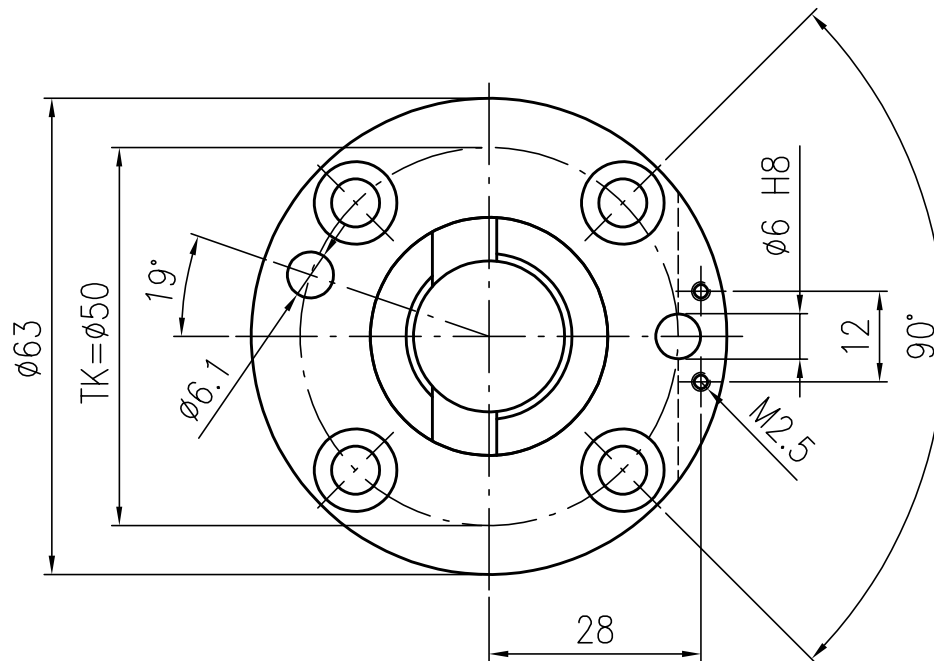
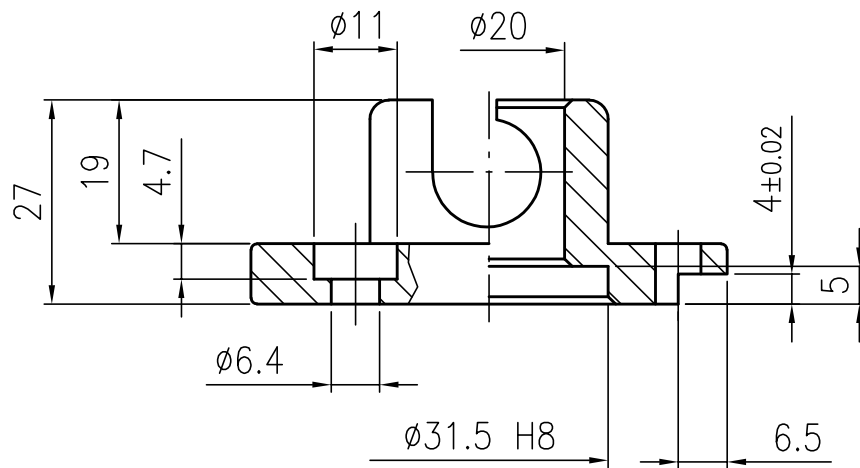

Grundmaterial	Bestellnummer Unterteil
Al. eloxiert	G-MGW063-2UE
Stahl	G-MGW063-2UES
St. nitriert	G-MGW063-2UEN

Datum 08.11.2016 Maßstab 1:1

Zeichnungsnummer
G-MGW063-2UE

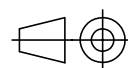

GRIP
GRIP GmbH Handhabungstechnik