

PRODUCT INFO

Base clamps BKG of die-cast aluminum have a clamping point machined with cutting methods without a clamping slit.

The base flange with four bores serves as an interface or for fastening the clamp to the place of use.

The bore at the clamping point is arranged perpendicular to the face of the flange. It receives typically available construction tubes with full surface contact over the entire cross-section of the bore.

A grub screw with a cup point acts radially at the screw point to reduce the cross-section of the bore. The bushing into which the grub screw is inserted is made of red brass.

A centering bore on the clamped tube prevents pressure points and enables precise positioning.

RoHS-compliant product

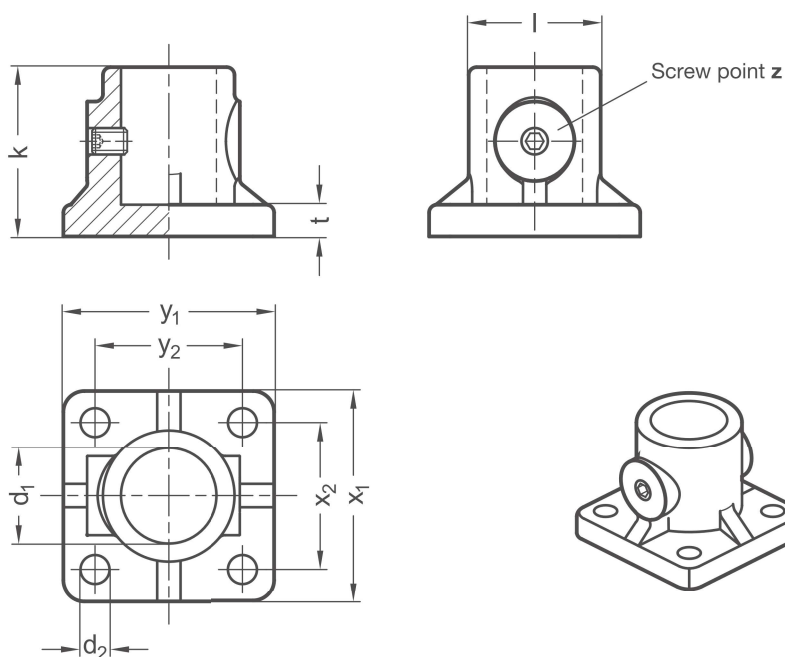

Clamping point									
Bore d_1	d_2	Clamping length k	l	t	x_1	x_2	y_1	y_2	Grub screw
B 10	5,5	32	25	6	40	28	40	28	M 6-6
B 12	5,5	32	25	6	40	28	40	28	M 6-6
B 14	5,5	32	25	6	40	28	40	28	M 6-6
B 15	5,5	32	25	6	40	28	40	28	M 6-6
B 16	5,5	32	25	6	40	28	40	28	M 6-6
B 18	5,5	32	25	6	40	28	40	28	M 6-6

Screw point z	
B	Grub screw with zinc-plated hex socket (DIN 913)
D	Grub screw with stainless steel hex socket (DIN 913)

Surface o	
2	Aluminum, textured powder-coated, Black RAL 9005
8	Aluminum, blasted, matt

ORDER KEY

BKG - d₁ - z - o

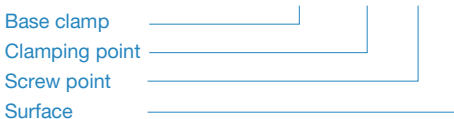

ON REQUEST

- Clamping point with special diameter
- Screw point with hex head screw, hex socket cap screw
- Surface ball-burnished, anodized or powder-coated in other RAL colors