

PRODUCT INFO

Attachment clamp mountings CGA are made of drawn aluminum profiles and have a slitted clamping point machined by cutting methods.

The clamping point bore is T-shaped relative to the attachment side. It receives rods and tubes with round or square cross-sections with the additionally incorporated square bore.

Attachment clamp mountings are intended for attaching sensor mounts SG and retaining plates SGU. on the attachment side, they have a central thread and, as of bore size $d_1 = B15$, also an additional bore pattern of 4 x M4.

For clamping, a stainless steel socket cap screw DIN 912-A2-70 combines with the clamping thread to reduce the bore cross-section. For regular tool-free clamping, adjustable hand lever sets are available as accessories under the designation HK.

RoHS-compliant product

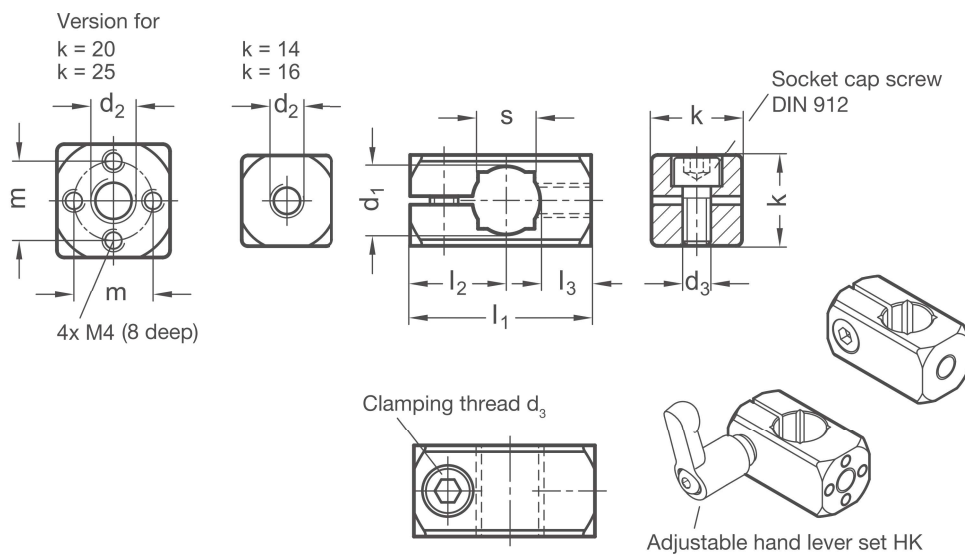

Clamping point				Clamping thread d₃	k	l₁	l₂	l₃	m	Square s	Accessories
Bore d₁	d₂										Hand lever set HK for d₃
B 8	M 5	-	-	M 4	14	25	13,5	7,5	-	-	M 4-14
B 10	M 5	M 6	M 8	M 5	16	30	17	8	-	8	M 5-16
B 12	M 5	M 6	M 8	M 5	16	32	17	9	-	10	M 5-16
B 15	M 6	M 8	-	M 6	20	40	20,5	12	14	12	M 6-20
B 16	M 6	M 8	-	M 6	20	40	20,5	11,5	14	-	M 6-20
B 20	M 8	M 10	-	M 6	25	45	21,5	12	17	16	M 6-25

Surface	
O	
G	Tumbled, matt
S	Anodized black

ORDER KEY

CGA - d₁ - d₂ - o

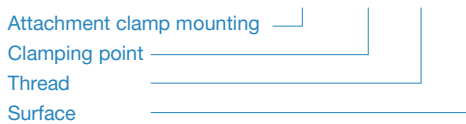

ACCESSORIES

– Adjustable hand lever set **HK** see page 172

ON REQUEST

- Clamping point with special diameter
- Screw point with hex head screw
- Surface anodized in colors