

PRODUCT INFO

Angle clamps ES of die-cast aluminum have cylindrical clamping points machined by cutting methods. Two clamping points have a slitted cross-section and one has no clamping slit.

All bores of the clamping points are arranged at an angle of 90° to each other. The slitted bores lie in a plane, while the bore cross-section without clamping slit is perpendicular to this plane. All bores receive typically available construction tubes with full surface contact over the entire cross-section.

At the screw points, hex socket cap screws or adjustable hand levers reduce the slitted bore cross-section. Grub screws with cup points act radially on the cross-section of the bore for clamping without a clamping slit. Centering bores on the clamped tube prevent pressure points and enable precise positioning.

Adjustable hand levers are intended for repeated, tool-free clamping. Under the designation HSK, these are available separately for individual use and in other designs. Compared with the tool-operated hex socket cap screw, the clamping force achievable with an adjustable hand lever is lower due to the shorter lever length.

RoHS-compliant product

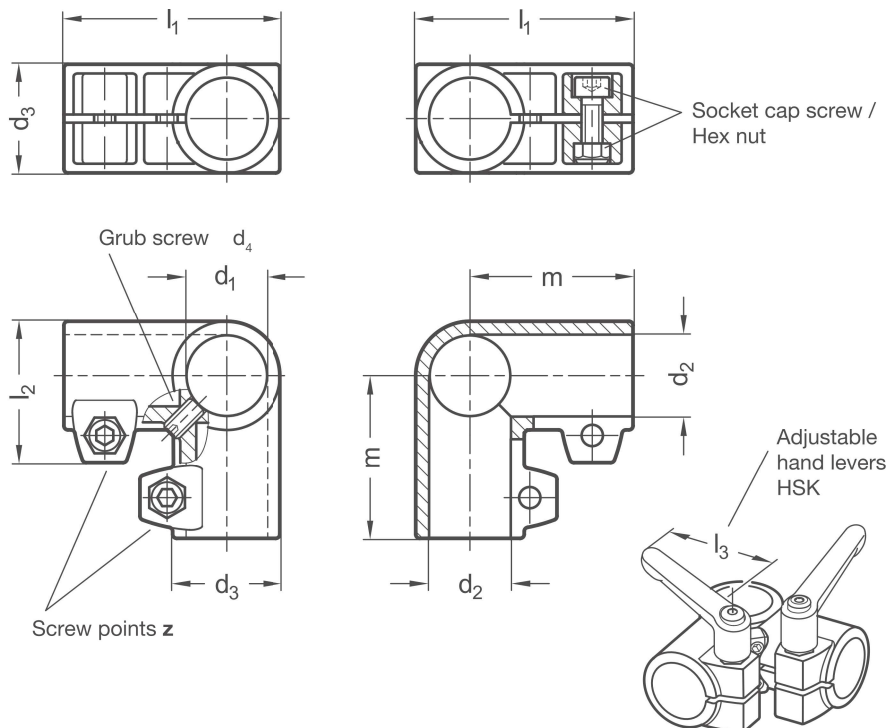

Clamping point 1	Clamping points 2							Accessories recom. hand lever
Bore d_1	Bore d_2	d_3	d_4	l_1	l_2	m	Hex socket cap screws	HSK for z lever length l_3
B 20	B 20	40	M 8	80	52	60	M 8-25	-
B 25	B 25	40	M 8	80	52	60	M 8-25	78
B 30	B 30	40	M 8	80	52	60	M 8-25	78
B 40	B 40	65	M 10	135,5	77,5	103	M 10-50	-
B 42	B 42	65	M 10	135,5	77,5	103	M 10-50	-
B 45	B 45	65	M 10	135,5	77,5	103	M 10-50	92
B 48	B 48	65	M 10	135,5	77,5	103	M 10-50	92
B 50	B 50	65	M 10	135,5	77,5	103	M 10-50	92

Screw points

Z

1	Hex socket cap screw steel, zinc-plated DIN 912-8.8 and lock nut steel DIN 985-8, zinc-plated / grub screw DIN 914 steel, zinc-plated
2	Hex socket cap screw stainless steel DIN 912-A2-70 and lock nut stainless steel DIN 985-A2, glide coating / grub screw stainless steel

Surface

O

2	textured powder-coated, Black RAL 9005
8	blasted, matt

ORDER KEY

ES - d_1 - d_2 - z - o



ACCESSORIES

– Adjustable hand levers **HSK** see page 168

ON REQUEST

- Clamping points with different diameters d_1 and d_2 or special diameter
- Screw points with hex head screws or mixed screw / adjustable hand lever elements
- Surface ball-burnished, anodized or powder-coated in other RAL colors