



PRODUCT INFO

Fastening lugs SP are made of polyamide by injection molding and have a slitted clamping point.

The lug is situated in a plane with and parallel to the clamping point bore, which receives rods and tubes with round cross-sections or also square cross-sections via the additionally incorporated square bore. A variety of types make fastening lugs suitable for all manner of uses.

Stainless steel screws and nuts reduce the bore cross-section for clamping.

The exceptionally lightweight plastic elements are well-suited for use in corrosive environments.

RoHS-compliant product



elesa
Original design MSX.

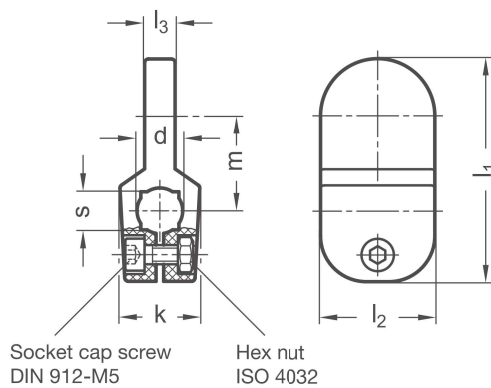

Application example

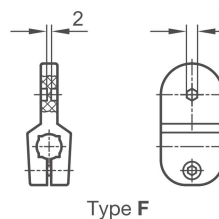
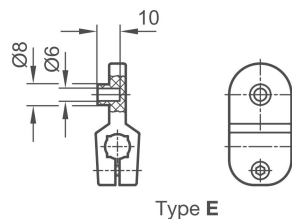
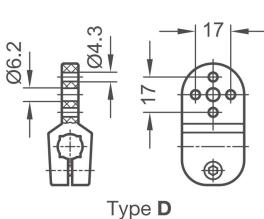
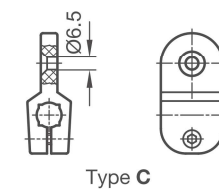
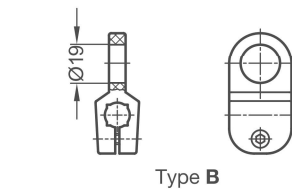
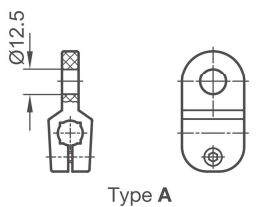
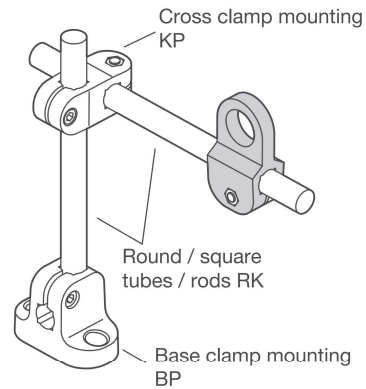

Clamping point							
Bore d	k	l₁	l₂	l₃	m		Square s
B 10	21	58,5	30	8	25		V 8
B 12	21	58,5	30	8	25		V 10
B 14	21	58,5	30	8	25		V 12

Type t	
A	For sensor mounting
B	For sensor mounting
C	With bore for countersunk screw M6
D	For reflector mounting
E	For reflector mounting
F	For inserting specific bores

ORDER KEY

SP - d - t

