

PRODUCT INFO

Sensor mounts SSP of die-cast aluminum have a slitted clamping point and a sensor bore, both machined by cutting methods.

The sensor bore allows attachment of sensors with male thread. It lies within a plane and parallel to the clamping point bore, which receives typically available construction tubes with full contact over the entire cross-section.

At the screw point, a hex socket cap screw or an adjustable hand lever reduces the bore cross-section for clamping.

Adjustable hand levers are intended for repeated, tool-free clamping. Under the designation HSK, these are available separately for individual use and in other designs. Compared with the tool-operated hex socket cap screw, the clamping force achievable with an adjustable hand lever is lower due to the shorter lever length.

RoHS-compliant product

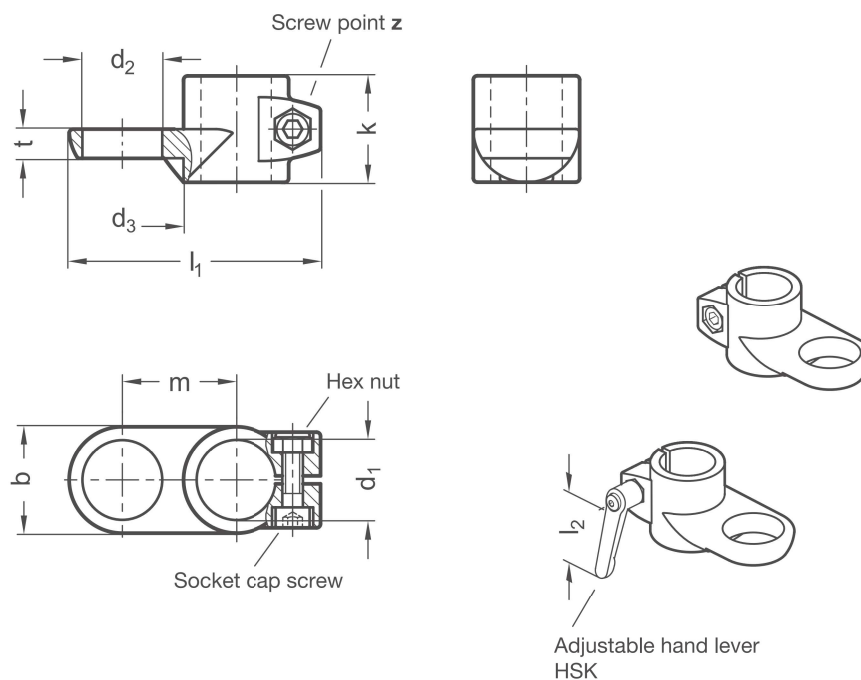

Clamping point	Sensor bore		Lug width b	d₃	k	l₁	m	t	Hex socket cap screw	Accessories recom. hand lever
	Bore d₁	d₂								HSK for z lever length l₂
B 20	B 18	B 30	40	50	40	95	43	10	M 8-25	-
B 25	B 18	B 30	40	50	40	95	43	10	M 8-25	78
B 30	B 18	B 30	40	50	40	95	43	10	M 8-25	78

Screw point
Z

1	Hex socket cap screw steel, zinc-plated DIN 912-8.8 and lock nut steel DIN 985-8, zinc-plated
2	Hex socket cap screw stainless steel DIN 912-A2-70 and lock nut stainless steel DIN 985-A2, glide coating

Surface
O

2	Aluminum, textured powder-coated, Black RAL 9005
---	--

ORDER KEY

SSP - d₁ - d₂ - z - o



ACCESSORIES

– Adjustable hand levers **HSK** see page 168

ON REQUEST

- Clamping points with special diameter
- Screw point with hex head screws
- Surface ball-burnished, anodized or powder-coated in other RAL colors