

### PRODUCT INFO

**T-clamp mountings TG** are made of drawn aluminum profiles and have a slitted clamping point machined by cutting methods.

The clamping point bore is T-shaped relative to the bolt and to the bore on the opposite side. It receives rods and tubes with round or square cross-sections via the additionally incorporated square bore.

T-clamp mountings of type W are suitable alternatives to swivel cross clamp mountings DGK if higher retaining torques are required.

For clamping, a stainless steel socket cap screw DIN 912-A2-70 combines with the clamping thread to reduce the cross-section of the clamping point bore. For regular tool-free clamping, adjustable hand lever sets are available as accessories under the designation HK.

**RoHS-compliant product**

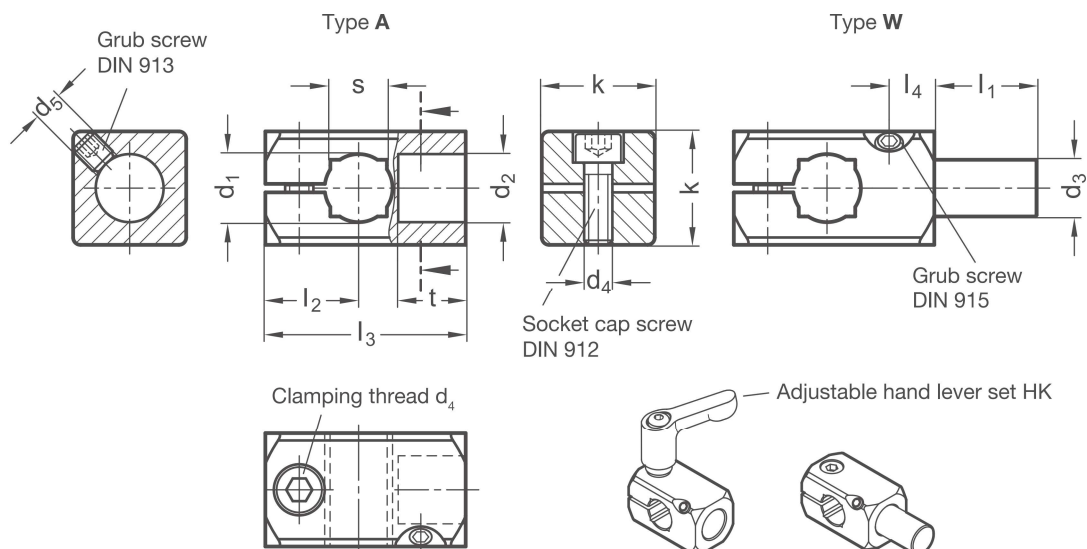

Clamping point		Type A <b>d<sub>2</sub></b>	Type W <b>d<sub>3</sub></b>	Clamping thread <b>d<sub>4</sub></b>	<b>k</b>	<b>d<sub>5</sub></b>	<b>l<sub>1</sub></b>	<b>l<sub>2</sub></b>	<b>l<sub>3</sub></b>	<b>l<sub>4</sub></b>	Square <b>s</b>	<b>t</b>	Accessories
Bore <b>d<sub>1</sub></b>	Hand lever set HK for <b>d<sub>4</sub></b>												
B 8	B 8	8	M 4	16	M 4	16	13	26	5,5	-	8	M 4-16	
B 10	B 10	10	M 5	20	M 5	17	15,5	31,5	7	8	10	M 5-20	
B 12	B 12	12	M 5	20	M 5	19	16,5	35,5	8	10	12	M 5-20	
B 15	B 15	15	M 6	25	M 6	21	20	43,5	10	12	15	M 6-25	
B 16	B 16	16	M 6	25	M 6	24	20	45	11	-	16	M 6-25	
B 20	B 20	20	M 6	30	M 6	26	22	51	12	16	18	M 6-30	

Type <b>t</b>	
A	With bore
W	With bolt (stainless steel, AISI 303)

Surface <b>o</b>	
G	Tumbled, matt
S	Anodized black

**ORDER KEY**

**TG - d<sub>1</sub> - d<sub>2</sub> / d<sub>3</sub> - t - o**

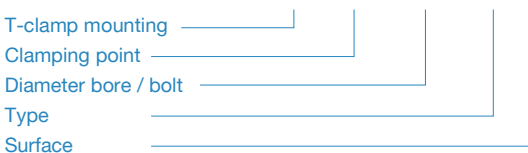

**ACCESSORIES**

– Adjustable hand lever set **HK** see page 172

**ON REQUEST**

- Clamping point with special diameter
- Screw point with hex head screw
- Surface anodized in colors

2D  
2C  
2B  
2A  
1D  
1C  
1B  
1A