



PRODUCT INFO

Flanged linear unit connectors FS.E of die-cast aluminum have a slitted bore machined by cutting methods, with or without a sliding insert. This is arranged in the plane parallel to the face of the flange.

Together with the guide tube of the linear unit, the guide element bore forms a solid linear round guide mechanism that can be adjusted and clamped for low play. Drive keys transmit the linear movement of the linear unit to the linear unit connector.

Depending on the design, the part to be moved is fastened to the guide element or the guide element itself is installed at the place of use such that the entire linear unit moves together. At the screw point, a hex socket cap screw or an adjustable hand lever reduces size of the guide element bore.

Adjustable hand levers are intended for repeated, tool-free clamping. Under the designation HSK, these are available separately for individual use and in other designs. Compared with the tool-operated hex socket cap screw, the clamping force achievable with an adjustable hand lever is lower due to the shorter lever length.

RoHS-compliant product

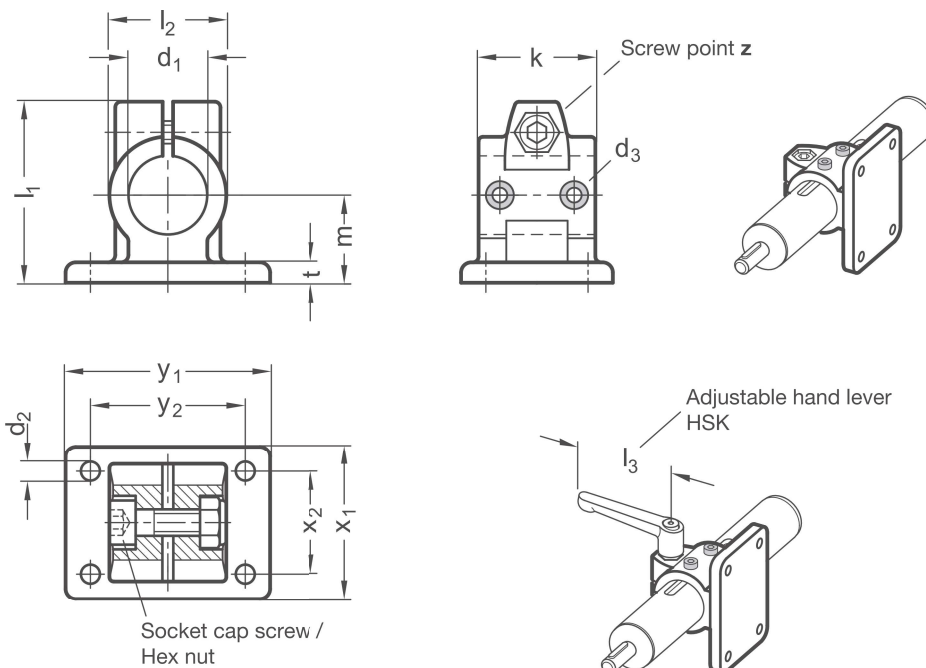

Clamping point		Clamping length k	d₂	Fastening screws on the drive key d₃	l₁	l₂	m	t	x₁	x₂	y₁	y₂	Hex socket cap screw	Accessories recom. hand lever
Bore d₁														HSK for z lever length l₃
Without sliding insert	With sliding insert													
B 30	G 30	40	6,5	M 4	62	40	30	7	52	35	70	53	M 8-25	78
B 30	G 30	56	8,5	M 4	83	56	42	10	78	52	108	82	M 10-35	-
B 40	G 40	56	8,5	M 5	83	56	42	10	78	52	108	82	M 10-35	92
B 40	G 40	65	11	M 5	95	65	50	14	92	62	128	98	M 10-50	-
B 50	G 50	65	11	M 6	95	65	50	14	92	62	128	98	M 10-50	92
B 60	G 60	80	11	M 8	112	80	60	14	110	74	154	118	M 10-50	92

Screw point **z**

1	Hex socket cap screw steel, zinc-plated DIN 912-8.8 and lock nut steel DIN 985-8, zinc-plated
2	Hex socket cap screw stainless steel DIN 912-A2-70 and lock nut stainless steel DIN 985-A2, glide coating

Surface **o**

2	textured powder-coated, Black RAL 9005
8	blasted, matt

ORDER KEY

FS.E - d₁ - k - z - o

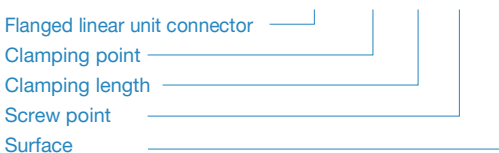

ACCESSORIES

– Adjustable hand levers **HSK** see page 168

ON REQUEST

– Surface
ball-burnished, anodized or powder-coated in other RAL colors

2D
2C
2B
2A
1D
1C
1B
1A