



PRODUCT INFO

Cross linear unit connectors KMU.E of die-cast aluminum have split clamping points and guide element bores that have been partially machined by cutting methods. The bores are offset in the plane and arranged at an angle of 90°.

Together with the guide tube of the linear unit, the guide element bores form a solid linear round or square guide mechanism that can be adjusted and clamped for low play. Centering bushes in the pass-through bores eliminate axial play. Drive keys transmit the linear movement of the linear unit to the linear unit connector.

Depending on the design, the part to be moved is fastened to the guide element or the guide element itself is installed at the place of use such that the entire linear unit moves together. At the screw points, hex socket cap screws or adjustable hand levers reduce the guide element bore or clamping point size.

Adjustable hand levers are intended for repeated, tool-free clamping. Under the designation HSK, these are available separately for individual use and in other designs. Compared with the tool-operated hex socket cap screw, the clamping force achievable with an adjustable hand lever is lower due to the shorter lever length.

RoHS-compliant product

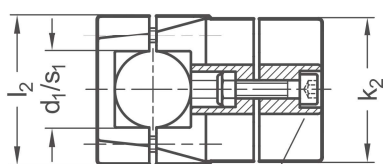
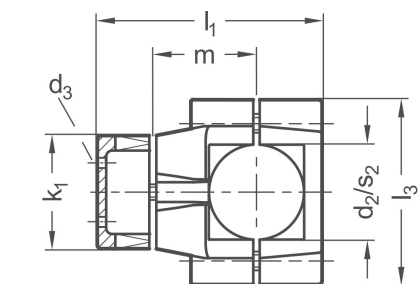

Socket cap screw /
Hex nut

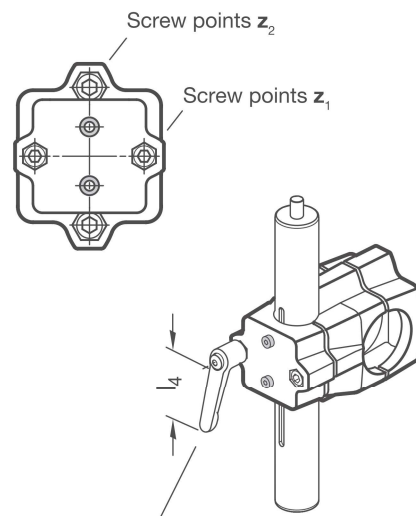

Adjustable hand lever
HSK

Clamping point 1		Clamping point 2		Mounting screws on the drive key d₃	Clamping length k₁	Clamping length k₂	l₁	l₂	l₃	m	z₁	z₂	Accessories recom. hand lever	
Bore d₁	Square s₁	Bore d₂	Square s₂										HSK for z₁ Lever length l₄	HSK for z₂ Lever length l₄
B 30	V 30	B 40	V 40	M 4	60	76	120	79	98	55	M 8-50	M 10-55	78	92
B 30	V 30	B 50	V 50	M 4	60	76	120	79	98	55	M 8-50	M 10-55	78	92
B 40	V 40	B 50	V 50	M 5	60	76	120	79	98	55	M 8-50	M 10-55	78	92

Screw points
z

1	Hex socket cap screw steel, zinc-plated DIN 912-8.8 and lock nut steel DIN 985-8, zinc-plated
2	Hex socket cap screw stainless steel DIN 912-A2-70 and lock nut stainless steel DIN 985-A2, glide coating

Surface
o

2	textured powder-coated, Black RAL 9005
8	blasted, matt

ORDER KEY **KMU.E - d₁ - d₂ - z - o**



ACCESSORIES

– Adjustable hand levers **HSK** see page 168

ON REQUEST

– Surface
ball-burnished, anodized or powder-coated in other RAL colors