



PRODUCT INFO

Cross linear unit connectors KS.E and KS.Z of die-cast aluminum have slitted clamping points and guide element bores machined by cutting methods, with or without a sliding insert. The bores are offset in the plane and arranged at an angle of 90°.

Together with the guide tube of the linear unit, the guide element bores form a solid linear round guide mechanism that can be adjusted and clamped for low play. Drive keys transmit the linear movement of the linear unit to the linear unit connector.

Depending on the design, the part to be moved is fastened to the guide element or the guide element itself is installed at the place of use such that the entire linear unit moves together. At the screw points, hex socket cap screws or adjustable hand levers reduce the guide element bore or clamping point size.

Adjustable hand levers are intended for repeated, tool-free clamping. Under the designation HSK, these are available separately for individual use and in other designs. Compared with the tool-operated hex socket cap screw, the clamping force achievable with an adjustable hand lever is lower due to the shorter lever length.

RoHS-compliant product

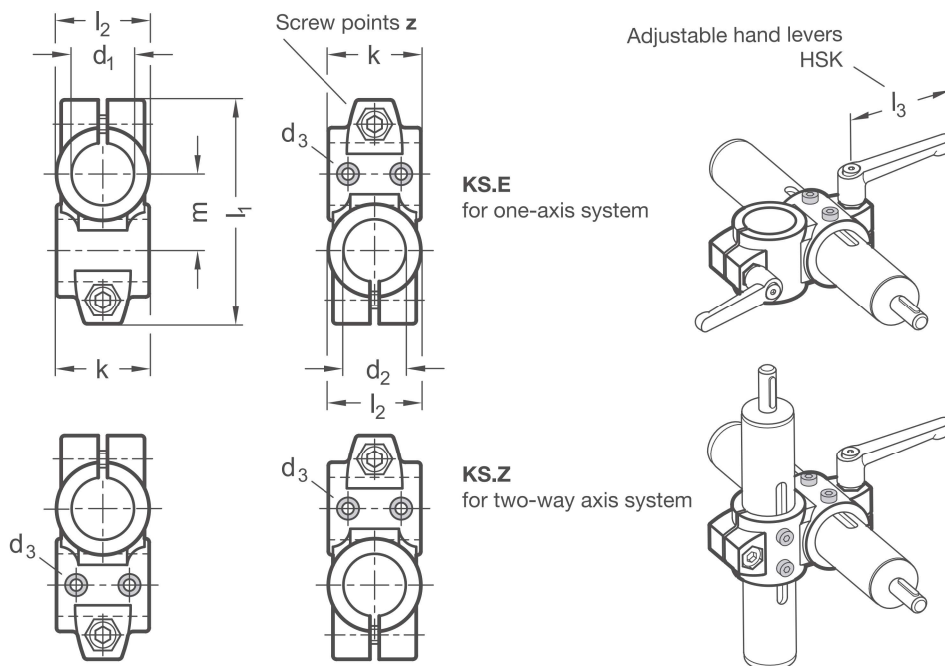

KS.E for one-axis systems

Clamping point 1 - 2		Clamping length k	Mounting screws on the drive key d₃	l₁	l₂	m	Hex socket cap screws	Accessories recom. hand lever
d₁ - d₂								HSK for z lever length l₃
Without sliding insert	With PTFE sliding insert							
B30 - B30	G30 - B30	40	M 4	97	40	33	M 8-25	78
B30 - B30	G30 - B30	56	M 4	125	56	45	M 10-35	-
B40 - B40	G40 - B40	56	M 5	125	56	45	M 10-35	92
B40 - B40	G40 - B40	65	M 5	143	65	53	M 10-50	-
B50 - B50	G50 - B50	65	M 6	143	65	53	M 10-50	92
B60 - B60	G60 - B60	80	M 8	169	80	65	M 10-50	92

KS.Z for two-axis systems

Clamping point 1 - 2		Clamping length k	Mounting screws on the drive key d₃	l₁	l₂	m	Hex socket cap screws	Accessories recom. hand lever
d₁ - d₂								HSK for z lever length l₃
Without sliding insert	With PTFE sliding insert							
B30 - B30	G30 - G30	40	M 4	97	40	33	M 8-25	78
B30 - B30	G30 - G30	56	M 4	125	56	45	M 10-35	-
B40 - B40	G40 - G40	56	M 5	125	56	45	M 10-35	92
B40 - B40	G40 - G40	65	M 5	143	65	53	M 10-50	-
B50 - B50	G50 - G50	65	M 6	143	65	53	M 10-50	92
B60 - B60	G60 - G60	80	M 8	169	80	65	M 10-50	92

Screw point z

1	Hex socket cap screw steel, zinc-plated DIN 912-8.8 and lock nut steel DIN 985-8, zinc-plated
2	Hex socket cap screw stainless steel DIN 912-A2-70 and lock nut stainless steel DIN 985-A2, glide coating

Surface o

2	textured powder-coated, Black RAL 9005
8	blasted, matt

ACCESSORIES

– Adjustable hand levers **HSK** see page 168

One-axis system

ORDER KEY

KS.E - d₁ - d₂ - k - z - o



Two-axis system

ORDER KEY

KS.Z - d₁ - d₂ - k - z - o

