

PRODUCT INFO

The guide tubes of the **precision double tube linear units PD1D** are made of chrome-plated steel or polished stainless steel precision tubes. The end pieces of aluminum connect the tubes and form a precise linear guide together with the guide element. The centered continuous spindle has trapezoidal or fine thread and ball bearings on both sides. The slide-guided double guide element is moved linearly along the spindle thread by the integrated spindle nut.

Double tube linear units have high torsional stiffness and can handle high weights and torques. The double guide element distributes the load among four guide points, allowing for even higher loads.

Accessory parts are listed in the tables and are already taken into account when selecting the linear units. This ensures, for example, that the lengths of the journals z_1 and z_2 are correct for attachment of the accessories. The accessories are not included with the linear units.

RoHS-compliant product

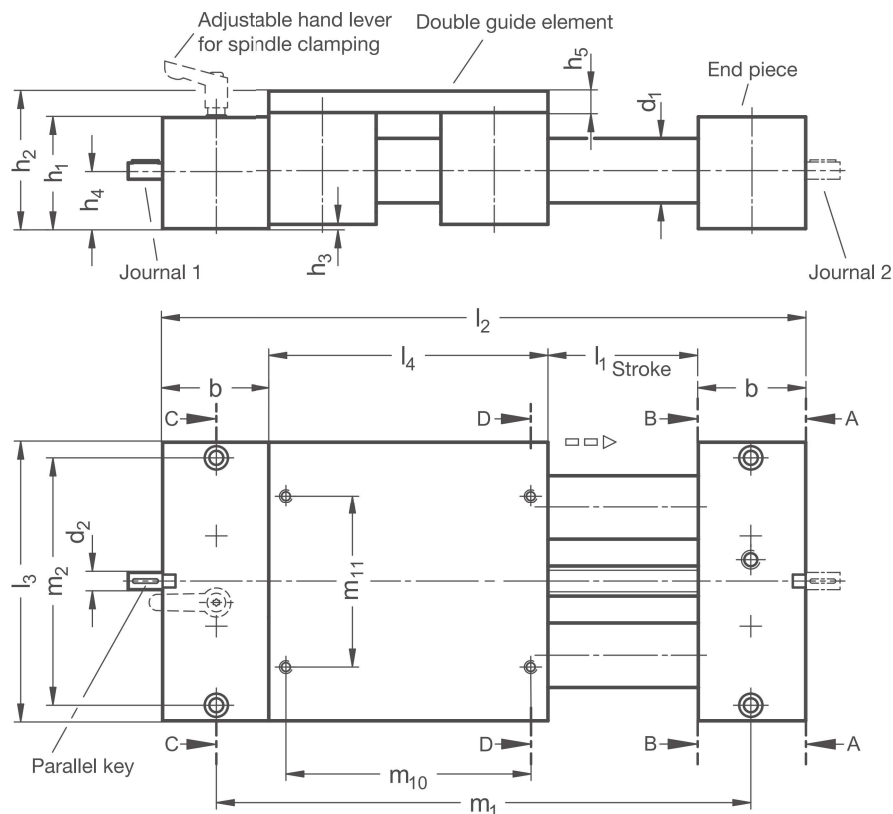

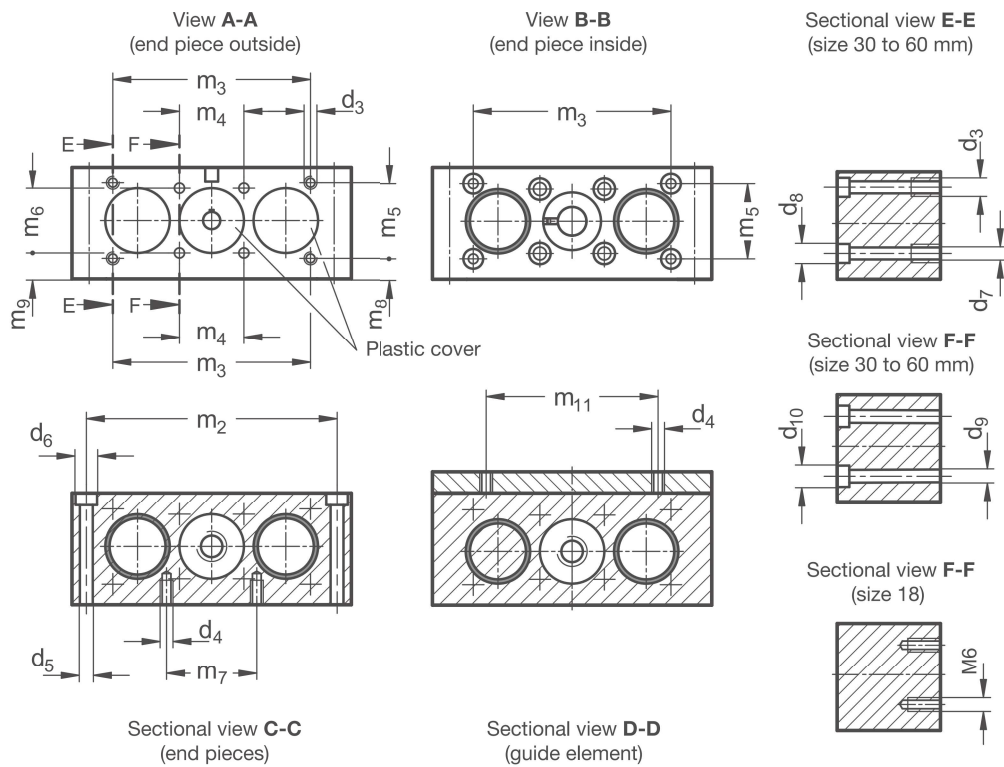

d_1	Stroke l_1	b	d_2	d_3	d_4	d_5	d_6	For screws DIN 912	d_7	d_8	For screws DIN 912	d_9	d_{10}	For screws DIN 912
18	...400	28	6	-	M 5	5,5	10	M 5	-	-	-	-	-	-
30	...1500	50	8	M 6	M 6	6,6	11	M 6	5,5	10	M 5	6,6	11	M 6
40	...2500	60	12	M 8	M 8	9	15	M 8	6,6	11	M 6	8,6	13,5	M 8
50	...2630	72	12	M 10	M 8	9	15	M 8	9	13,5	M 8	9	13,5	M 8
60	...2580	80	14	M 10	M 10	10,5	16,5	M 10	9	13,5	M 8	11	16,5	M 10

d_1	h_1	h_2	h_3	h_4	h_5	l_2	l_3	l_4	m_1	m_2	m_3	m_4	m_5	m_6
18	28	37	1	14,5	8	$2xb+l_4+l_1$	81	81	$b+l_4+l_1$	68	-	20	-	20
30	52	64	2	27	10	$2xb+l_4+l_1$	130	130	$b+l_4+l_1$	114	92	30	35	30
40	60	75	3	31,5	12	$2xb+l_4+l_1$	180	180	$b+l_4+l_1$	160	132	39	38	39
50	72	92	4	38	16	$2xb+l_4+l_1$	206	206	$b+l_4+l_1$	184	150	46	50	46
60	86	106	4	45	16	$2xb+l_4+l_1$	240	240	$b+l_4+l_1$	216	185	55	60	55

d_1	m_7	m_8	m_9	m_{10}	m_{11}	Accessories:					
						Parallel key DIN 6885	Torque support	Position indicator		Handwheel	
18	18	-	4,5	68	52	A2x2x12	VZDD	VZPM		-	VZH
30	42	9,5	12	114	80	A2x2x12	-	VZPM (only for stroke ≤ 1000 mm)		VZPE	VZH
40	62	12,5	12	160	120	A4x4x12	-	VZPM		VZPE	VZH
50	62	13	15	184	134	A4x4x12	-	VZPM		VZPE	VZH
60	74	15	17,5	216	160	A5x5x16	-	VZPM (only for trapezoidal thread)		VZPE	VZH

Version
a

1ST	Double tube sliding guide / trapezoidal lead screw • Guide tubes: Steel, chrome-plated • End pieces / guide elements: Aluminum, bright. Assembly surfaces: Machined • Trapezoidal / fine thread spindle: Steel, with ball bearing
1ED	Double tube sliding guide / trapezoidal lead screw • Guide tubes: Stainless steel AISI 304, polished • End pieces / guide elements: Aluminum, bright. Assembly surfaces: Machined • Trapezoidal / fine thread spindle: Stainless steel AISI 303, with ball bearing

Spindle thread direction / clamping
r

RH	Right-hand thread
RHK	Right-hand thread with clamping ring and hand lever for spindle clamping
LH	Left-hand thread
LHK	Left-hand thread with clamping ring and hand lever for spindle clamping

d_1	Spindle \emptyset	Spindle pitch p		Journal diameter d_2	Journal length B l_5	Journal length C l_6	Journal length D l_7	Individual journal length l_8
		Trapezoidal thread	Fine thread, metric					
18	10	3	1	6	16	30	48	16...46
30	14	4	1	8	16	36	52	16...67
40	20	4	1	12	17	42	59	17...74
50	20	4	1	12	18	42	60	18...75
60	24	5	1,5	14	19	42	61	19...76

Journal
Z₁

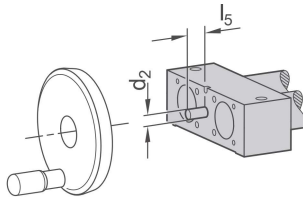
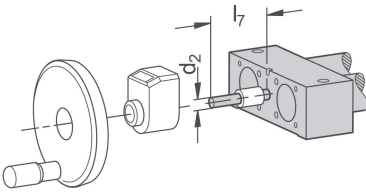
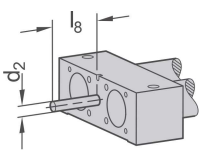
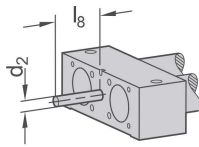
B	Journal for handwheel	D	Journal for position indicator and handwheel (torque support required for $d_1=18$)	Gxx	Individual journal length with keyway (for xx, enter values from column l_8)
 <p>Journal length l_5</p>		 <p>Journal length l_7</p>		 <p>Journal length l_8</p>	
Hxx	Individual journal length without keyway (for xx, enter values from column l_8)				
 <p>Journal length l_8</p>					

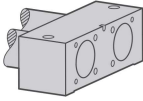
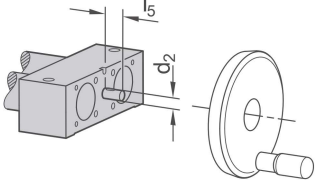
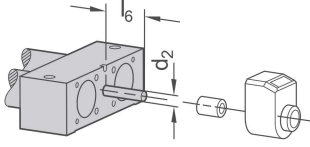
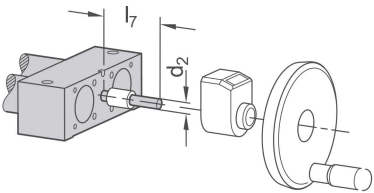
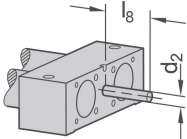
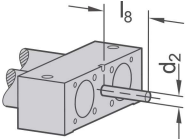
Journal Z_2								
A	Without journal		B	Journal for handwheel		C	Journal for position indicator (torque support required for $d_1=18$)	
			 <p>Journal length l_5</p>			 <p>Journal length l_6</p>		
D	Journal for position indicator and handwheel (torque support required for $d_1=18$)		Gxx	Individual journal length with keyway (for xx, enter values from column l_8)		Hxx	Individual journal length without keyway (for xx, enter values from column l_8)	
 <p>Journal length l_7</p>			 <p>Journal length l_8</p>			 <p>Journal length l_8</p>		

ORDER KEY

Name key	Supplemental key
PD1D - d ₁ - a - l ₁ - r - p - z ₁ - z ₂	

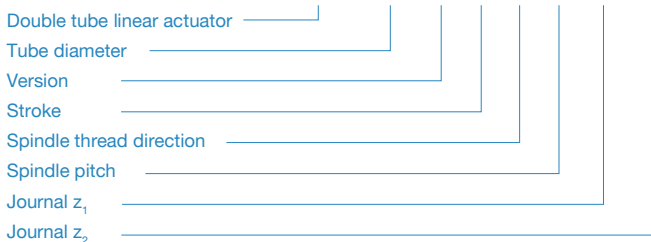

ACCESSORIES

- Handwheels **VZH** → see page 356
- Position indicators **VZPM / VZPE** → see page 358 / 360
- Torque supports **VZDD** → see page 368
- Angle gears **YLD** → see page 378
- Transfer units **VA** → see page 370

ON REQUEST

- Additional following guide elements
- Guide element connector plates
- Multiple guide elements with scissors synchronization
- Bellows covers
- Complete linear unit of stainless steel