



PRODUCT INFO

The round guides of the **precision double tube linear units PD1E** are available either as tubes or solid shafts. They are made of chrome-plated or hard-chrome-plated steel or polished stainless steel. The end pieces of aluminum connect the tubes or solid shafts and form a precise linear guide together with the guide element. The centered continuous spindle has trapezoidal or fine thread and ball bearings on both sides. The single guide element is moved linearly along the spindle thread by the integrated spindle nut. The single guide element has either a sliding or roller guide.

Double tube linear units have high torsional stiffness and can handle high weights and torques. Depending on the requirements, the part to be moved is fastened to the guide element or the guide element itself is installed at the place of use such that the entire linear unit moves together.

Accessory parts are listed in the tables and are already taken into account when selecting the linear units. This ensures, for example, that the lengths of the journals z_1 and z_2 are correct for attachment of the accessories. The accessories are not included with the linear units.

RoHS-compliant product

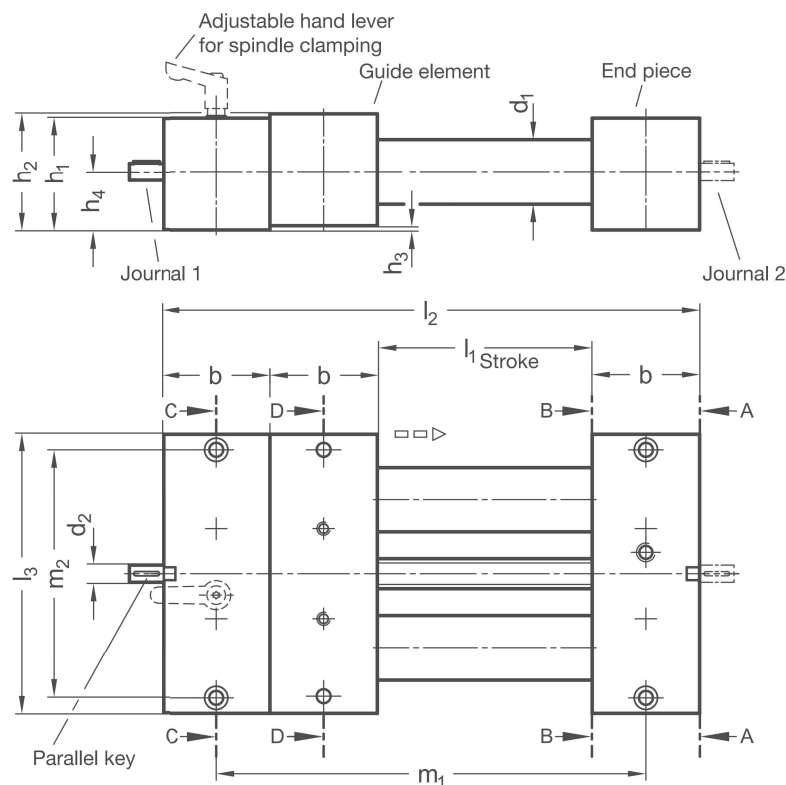

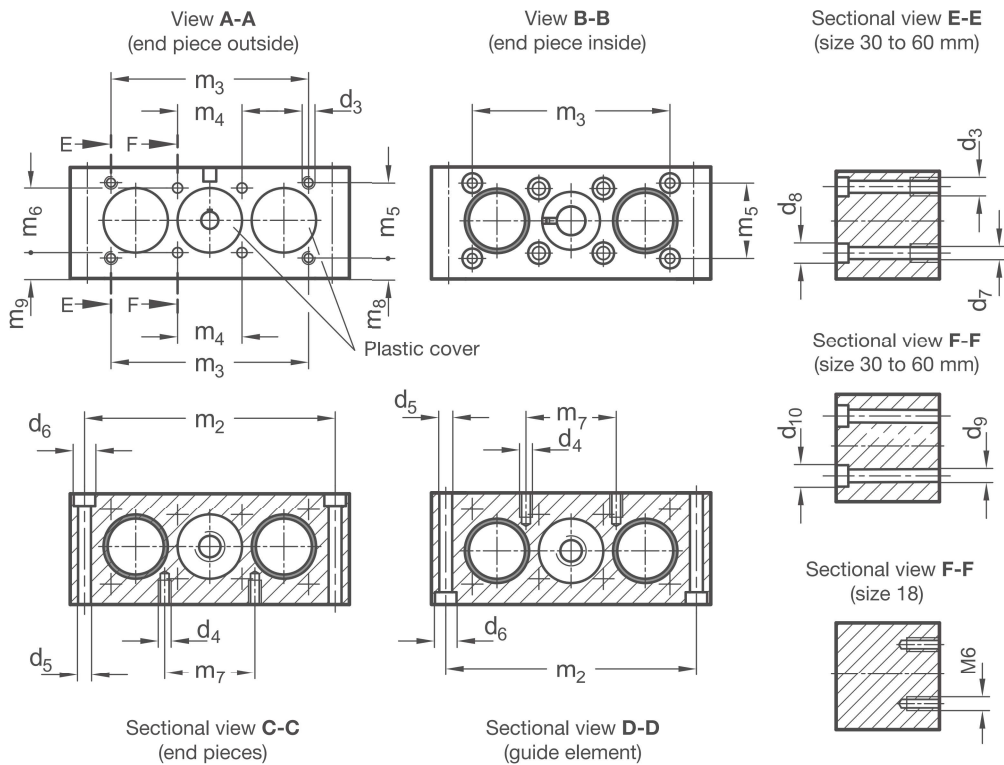

d_1	Stroke l_1	b	d_2	d_3	d_4	d_5	d_6	For screws DIN 912	d_7	d_8	For screws DIN 912	d_9	d_{10}	For screws DIN 912
18	...420	28	6	-	M 5	5,5	10	M 5	-	-	-	-	-	-
25*	...1500	50	8	M 6	M 6	6,1	10,5	M 6	5,5	10	M 5	6,6	11	M 6
30	...1500	50	8	M 6	M 6	6,6	11	M 6	5,5	10	M 5	6,6	11	M 6
40	...2650	60	12	M 8	M 8	8,4* / 9	13,5* / 15	M 8	6,6	11	M 6	8,6	13,5	M 8
50	...2760	72	12	M 10	M 8	9	15	M 8	9	13,5	M 8	9	13,5	M 8
60	...2740	80	14	M 10	M 10	10,5	16,5	M 10	9	13,5	M 8	11	16,5	M 10

d_1	h_1	h_2	h_3	h_4	l_2	l_3	m_1	m_2	m_3	m_4	m_5	m_6	m_7
18	28	29	1	14,5	$3xb+l_1$	81	$2xb+l_1$	68	-	20	-	20	18
25*	52	54	2	27	$3xb+l_1$	130	$2xb+l_1$	114	97	30	35	30	42
30	52	54	2	27	$3xb+l_1$	130	$2xb+l_1$	114	92	30	35	30	42
40	60	63	3	31,5	$3xb+l_1$	180	$2xb+l_1$	160	138* / 132	39	38	39	52* / 62
50	72	76	4	38	$3xb+l_1$	206	$2xb+l_1$	184	150	46	50	46	62
60	86	90	4	45	$3xb+l_1$	240	$2xb+l_1$	216	185	55	60	55	74

d_1	m_8	m_9	Accessories:				
			Parallel key DIN 6885	Torque support	Position indicator	Handwheel	
18	-	4,5	A2x2x12	VZDD	VZPM	-	VZH
25*	9,5	12	A2x2x12	-	VZPM (only for stroke \leq 1000 mm)	VZPE	VZH
30	9,5	12	A2x2x12	-	VZPM (only for stroke \leq 1000 mm)	VZPE	VZH
40	12,5	12	A4x4x12	-	VZPM	VZPE	VZH
50	13	15	A4x4x12	-	VZPM	VZPE	VZH
60	15	17,5	A5x5x16	-	VZPM (only for trapezoidal thread)	VZPE	VZH

* Only for version a = 2ST / 2ED

2D
2C
2B
2A
1D
1C
1B
1A

Version
a

1ST	Double tube sliding guide / trapezoidal lead screw • Guide tubes: Steel, chrome-plated • End pieces / guide elements: Aluminum, bright. Assembly surfaces: Machined • Trapezoidal / fine thread spindle: Steel, with ball bearing	2ST	Double solid shaft roller slideway / trapezoidal lead screw (only for $d_1 = 25$ and $d_1 = 40$) • Solid guide shafts: Steel, polished and hard-chrome-plated • End pieces / guide elements: Aluminum, CNC-milled parts • Trapezoidal / fine thread spindle: Steel, with ball bearing
1ED	Double tube sliding guide / trapezoidal lead screw • Guide tubes: Stainless steel AISI 304, polished • End pieces / guide elements: Aluminum, bright. Assembly surfaces: Machined • Trapezoidal / fine thread spindle: Stainless steel AISI 303, with ball bearing	2ED	Double solid shaft roller slideway / trapezoidal lead screw (only for $d_1 = 25$ and $d_1 = 40$) • Solid guide shafts: Stainless steel, induction-hardened and polished • End pieces / guide elements: Aluminum, CNC-milled parts • Trapezoidal / fine thread spindle: Stainless steel AISI 303, with ball bearing

Spindle thread direction / clamping
r

RH	Right-hand thread
RHK	Right-hand thread with clamping ring and hand lever for spindle clamping
LH	Left-hand thread
LHK	Left-hand thread with clamping ring and hand lever for spindle clamping

d_1	Spindle \varnothing	Spindle pitch p		Journal diameter d_2	Journal length B l_4	Journal length C l_5	Journal length D l_6	Individual journal length l_7
		Trapezoidal thread	Fine thread, metric					
18	10	3	1	6	16	30	46	16...46
25	14	4	1	8	16	36	52	16...67
30	14	4	1	8	16	36	52	16...67
40	20	4	1	12	17	42	59	17...74
50	20	4	1	12	18	42	60	18...75
60	24	5	1,5	14	19	42	61	19...76

Journal
Z₁

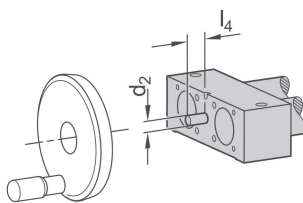
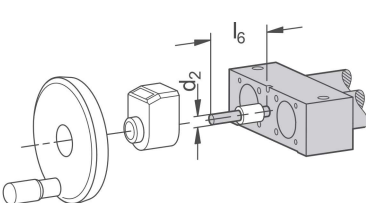
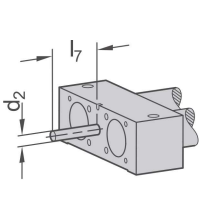
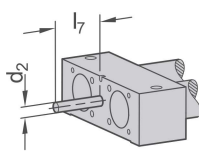
B	Journal for handwheel	D	Journal for position indicator and handwheel (torque support required for $d_1=18$)	Gxx	Individual journal length with keyway (for xx, enter values from column l_7)
 <p>Journal length l_4</p>		 <p>Journal length l_6</p>		 <p>Journal length l_7</p>	
Hxx	Individual journal length without keyway (for xx, enter values from column l_7)				
 <p>Journal length l_7</p>					

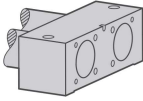
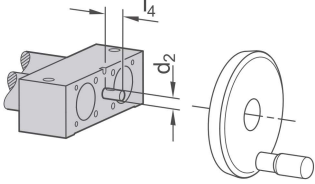
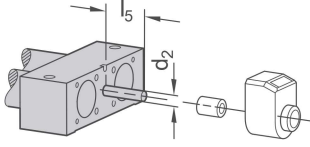
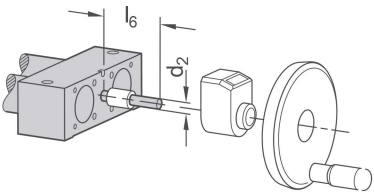
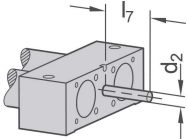
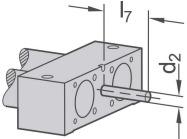
Journal Z_2								
A	Without journal		B	Journal for handwheel		C	Journal for position indicator (torque support required for $d_1=18$)	
			 <p>Journal length l_4</p>			 <p>Journal length l_5</p>		
D	Journal for position indicator and handwheel (torque support required for $d_1=18$)		Gxx	Individual journal length with keyway (for xx, enter values from column l_7)		Hxx	Individual journal length without keyway (for xx, enter values from column l_7)	
 <p>Journal length l_6</p>			 <p>Journal length l_7</p>			 <p>Journal length l_7</p>		

ORDER KEY

Name key | Supplemental key
PD1E - d₁ - a - l₁ - r - p - z₁ - z₂

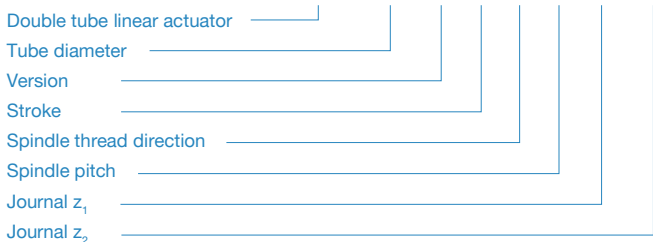

ACCESSORIES

- Handwheels **VZH** → see page 356
- Position indicators **VZPM / VZPE** → see page 358 / 360
- Torque supports **VZDD** → see page 368
- Angle gears **YLD** → see page 378
- Transfer units **VA** → see page 370

ON REQUEST

- Additional following guide elements
- Guide element connector plates
- Multiple guide elements with scissors synchronization
- Bellows covers
- Complete linear unit of stainless steel