



PRODUCT INFO

Drive and transfer units VA are used together with angle gears and T-gears to introduce rotational movements and to transmit rotational movements between two linear units.

The drive units are available in the indicated standard lengths l_1 and are intended for the installation of handwheels on angle gears.

Transfer units are generally longer and are manufactured in special lengths l_1 to millimeter precision for the specific application. They transmit rotational movements over relatively large distances, e.g. between linear units, other transfer units or handwheels.

With an angle gear set of type 1, the drive and transfer units can be mounted to a single linear unit.

RoHS-compliant product

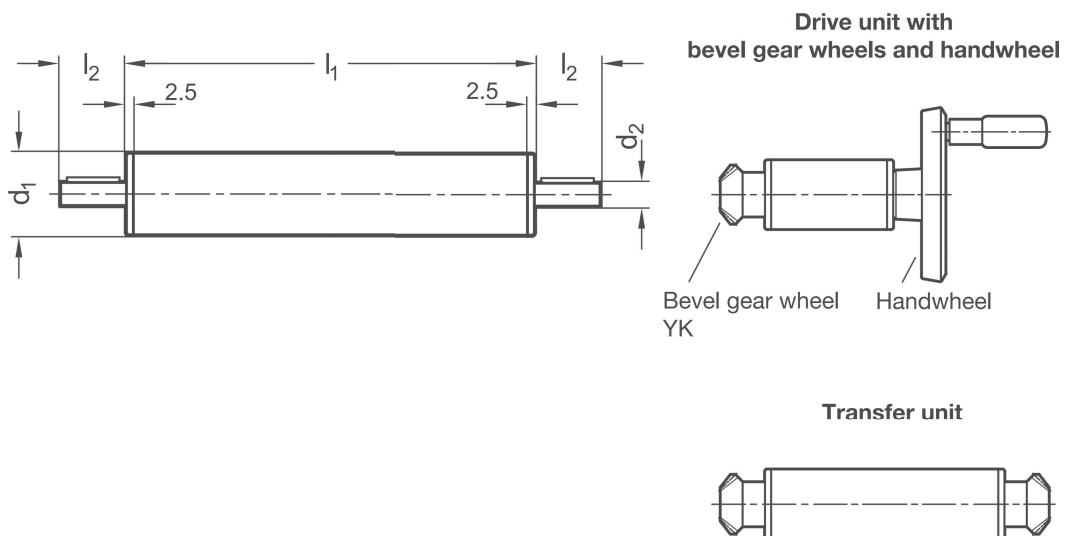

d ₁	l ₁		d ₂	l ₂
	Drive units standard lengths	Transmission units special manufacturing		
18	47	42...500	6	16
30	60	55...2000	8	16
40	93	88...2500	12	17
50	93	88...2500	12	18
60	95	90...2800	14	19

Material	
w	
ST	Steel • Guide tube, DIN EN 10305-4 chrome-plated steel • Shaft steel, with ball bearing • End plug plastic
ED	Stainless steel • Guide tubes, EN 10216-5, stainless steel AISI 304 • Shaft stainless steel AISI 303, with ball bearing • End plug plastic

ORDER KEY

VA - d₁ - l₁ - w

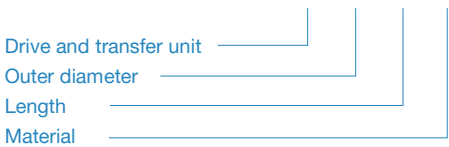

ON REQUEST

- Lengths, see table
- more journal lengths, see product group 2A