

PRODUCT INFO

The guide tubes of the **double tube linear units VD1D** are made of chrome-plated steel or polished stainless steel precision tubes. The aluminum end pieces connect the tubes and form a solid linear guide together with the guide element. A continuous spindle with ball bearings on each side is installed in the center. Together with the double guide element, the affixed spindle nut moves linearly along the spindle thread.

Double tube linear units have high torsional stiffness and can handle high weights and torques. The double guide element distributes the load among four guide points, allowing for higher loads. Depending on the design, the part to be moved is fastened to the guide element or the guide element itself is installed at the place of use such that the entire linear unit moves together.

Possible accessories are already taken into account in the selection of the linear units according to the options given in the tables. This ensures, for example, that the journal lengths z_1 and z_2 are appropriate for attachment of the accessories. The accessories are not included with the linear units.

RoHS-compliant product

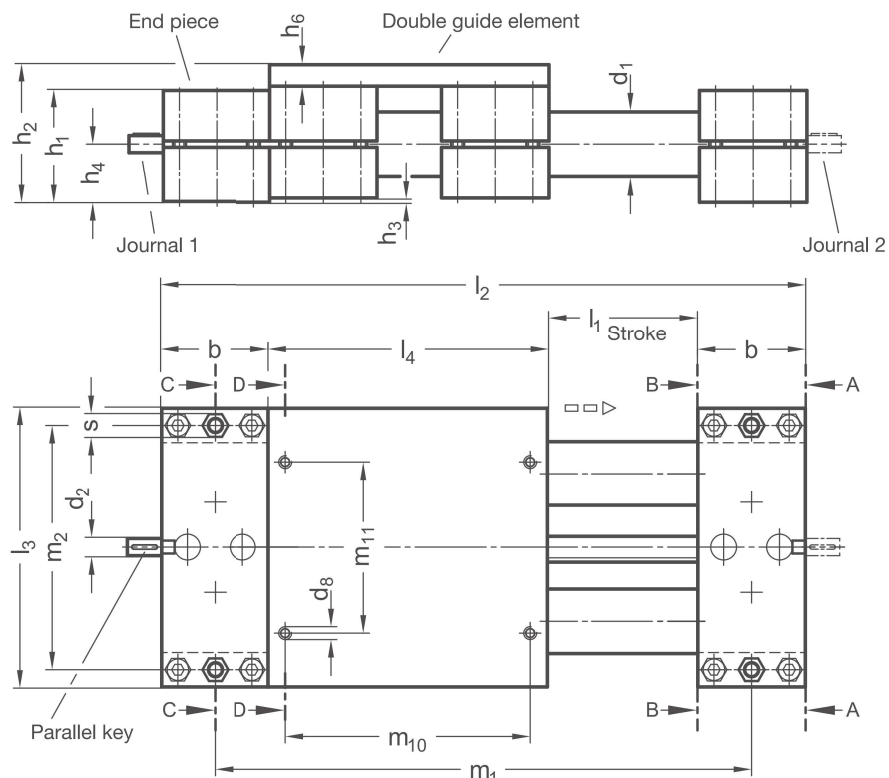

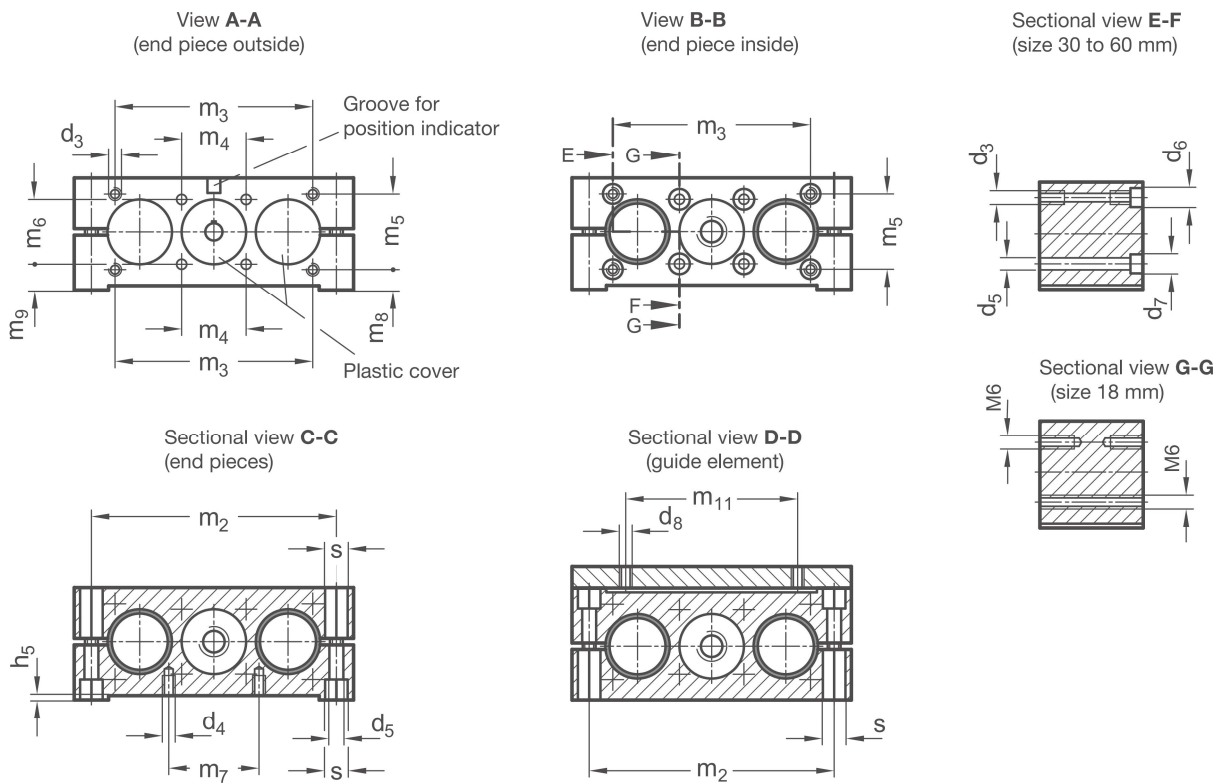

d_1	Stroke l_1	b	d_2	d_3^*	d_4^{**}	d_5	d_6	For screws DIN 912	d_7	For screws DIN 912	d_8	h_1	h_2	h_3	h_4
18	...400	28	6	-	M 5	5,3	-	-	-	-	M 5	28	37	1	14,5
30	...1500	50	8	M 6	M 6	6,5	9	M 5	10,5	M 6	M 6	52	64	2	27
40	...2500	60	12	M 8	M 8	8,5	13,5	M 6	13,5	M 8	M 8	60	75	3	31,5
50	...2630	72	12	M 10	M 8	8,5	13,5	M 8	13,5	M 8	M 8	72	92	4	38
60	...2580	80	14	M 10	M 10	10,5	13,5	M 8	16,5	M 10	M 10	86	106	4	45

d_1	h_5	h_6	l_2	l_3	l_4	m_1	m_2	m_3	m_4	m_5	m_6	m_7	m_8
18	0,75	8	$2xb + l_4 + l_1$	81	81	$b + l_4 + l_1$	68	-	20	-	20	18	-
30	0,85	10	$2xb + l_4 + l_1$	130	130	$b + l_4 + l_1$	114	92	30	35	30	42	9,5
40	1,05	12	$2xb + l_4 + l_1$	180	180	$b + l_4 + l_1$	160	132	39	38	39	62	12,5
50	1,2	16	$2xb + l_4 + l_1$	206	206	$b + l_4 + l_1$	184	150	46	50	46	62	13
60	1,35	16	$2xb + l_4 + l_1$	240	240	$b + l_4 + l_1$	216	185	55	60	55	74	14

d_1	m_9	m_{10}	m_{11}	s	Parallel key DIN 6885	Accessories:			Handwheel	
						Torque support	Clamping plate	Position indicator		
18	4,5	68	52	8	A2x2x12	VZDD	-	VZPM	-	VZH
30	12	114	80	10	A2x2x12	-	VZK	VZPM (only for stroke \leq 1000 mm)	VZPE	VZH
40	12	160	120	13	A4x4x12	-	VZK	VZPM	VZPE	VZH
50	15	184	134	13	A4x4x12	-	VZK	VZPM	VZPE	VZH
60	16,5	216	160	17	A5x5x16	-	VZK	VZPM (only for trapezoidal thread)	VZPE	VZH

* usable thread depth on both sides min. $2 \times d_3$ ** usable thread depth min. $1,5 \times d_4$

Material
W

ST	Aluminum - steel • Guide tubes: Steel, chrome-plated • End pieces / guide elements: Aluminum, bright. Assembly surfaces: Machined • Trapezoidal / fine thread spindle: Steel, with ball bearing	STS	Aluminum - steel • Guide tubes: Steel, chrome-plated • End pieces / guide elements: Aluminum, powder-coated, Black RAL 9005, Assembly surfaces: Machined bright • Trapezoidal / fine thread spindle: Steel, with ball bearing
ED	Aluminum - stainless steel • Guide tubes: Stainless steel AISI 304, polished • End pieces / guide elements: Aluminum, bright. Assembly surfaces: Machined • Trapezoidal / fine thread spindle: Stainless steel AISI 303, with ball bearing	EDS	Aluminum - stainless steel • Guide tubes: Stainless steel AISI 304, polished • End pieces / guide elements: Aluminum, powder-coated, Black RAL 9005, Assembly surfaces: Machined bright • Trapezoidal / fine thread spindle: Stainless steel AISI 303, with ball bearing

Spindle thread direction
r

RH	Right-hand thread
LH	Left-hand thread

d ₁	Spindle Ø	Spindle pitch p		Journal diameter d ₂	Journal length B l ₅	Journal length C l ₆	Journal length D l ₇	Journal length E l ₈	Journal length F l ₉	Individual journal length l ₁₀
		Trapezoidal thread	Fine thread, metric							
18	10	3	1	6	16	30	46	-	-	16...46
30	14	4	1	8	16	36	52	31	67	16...67
40	20	4	1	12	17	42	59	32	74	17...74
50	20	4	1	12	18	42	60	33	75	18...75
60	24	5	1,5	14	19	42	61	34	76	19...76

Journal
Z₁

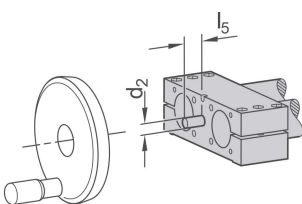
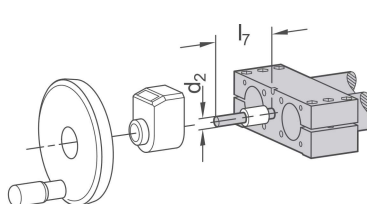
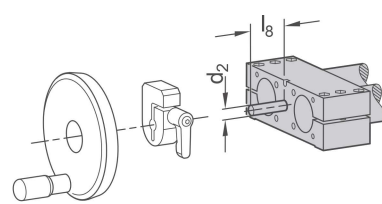
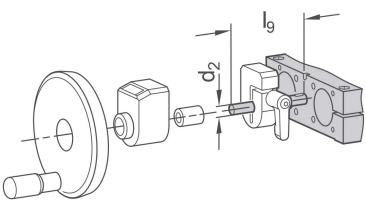
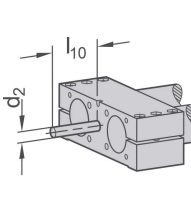
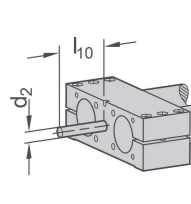
B	Journal for handwheel	D	Journal for position indicator and handwheel (torque support required for d ₁ = 18)	E	Journal for spacer plate and handwheel (only for d ₁ ≥ 30)
 <p>Journal length l₅</p>		 <p>Journal length l₇</p>		 <p>Journal length l₈</p>	
F	Journal for spacer plate, Position indicator und handwheel (only for d ₁ ≥ 30)	Gxx	Individual journal length with keyway (for xx, enter values from column l ₁₀)	Hxx	Individual journal length without keyway (for xx, enter values from column l ₁₀)
 <p>Journal length l₉</p>		 <p>Journal length l₁₀</p>		 <p>Journal length l₁₀</p>	

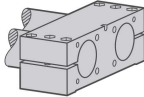
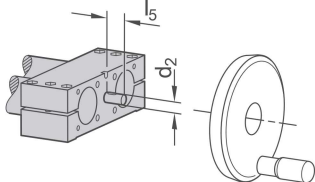
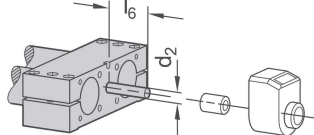
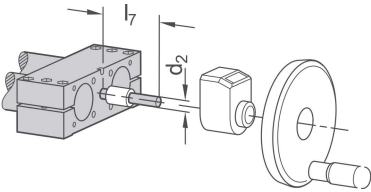
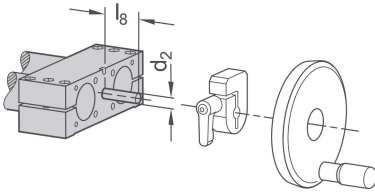
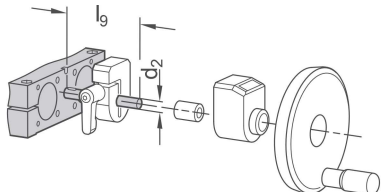
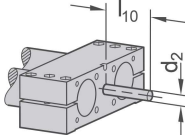
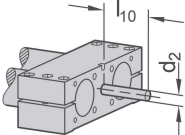
Journal Z_2	
A	Without journal  Journal length l_5
B	Journal for handwheel  Journal length l_5
C	Journal for position indicator (torque support required for $d_1=18$)  Journal length l_6
D	Journal for position indicator and handwheel (torque support required for $d_1=18$)  Journal length l_7
E	Journal for spacer plate and handwheel (only for $d_1 \geq 30$)  Journal length l_8
F	Journal for spacer plate, position indicator and handwheel (only for $d_1 \geq 30$)  Journal length l_9
Gxx	Individual journal length with keyway (for xx, enter values from column l_{10})  Journal length l_{10}
Hxx	Individual journal length without keyway (for xx, enter values from column l_{10})  Journal length l_{10}

ORDER KEY

Name key | Supplemental key
VD1D - d₁ - w - l₁ - r - p - z₁ - z₂

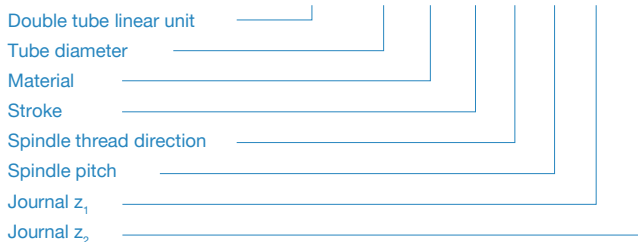

ACCESSORIES

- Handwheels **VZH** → see page 356
- Position indicators **VZPM / VZPE** → see page 358 / 360
- Clamping plates **VZK** → see page 362
- Torque supports **VZDD** → see page 368
- Angle gears **YLD** → see page 378
- Transfer units **VA** → see page 370

ON REQUEST

- Additional following guide elements
- Guide element connector plates
- Multiple guide elements with scissors synchronization
- Bellows covers