



PRODUCT INFO

The guide tubes of the **double tube linear units VD1E** are made of chrome-plated steel or polished stainless steel precision tubes. The aluminum end pieces connect the tubes and form a solid linear guide together with the guide element. A continuous spindle with ball bearings on each side is installed in the center. Together with the single guide element, the affixed spindle nut moves linearly along the spindle thread.

Double tube linear units have high torsional stiffness and can handle high weights and torques. Depending on the design, the part to be moved is fastened to the guide element or the guide element itself is installed at the place of use such that the entire linear unit moves together.

Possible accessories are already taken into account in the selection of the linear units according to the options given in the tables. This ensures, for example, that the journal lengths z_1 and z_2 are appropriate for attachment of the accessories. The accessories are not included with the linear units.

RoHS-compliant product

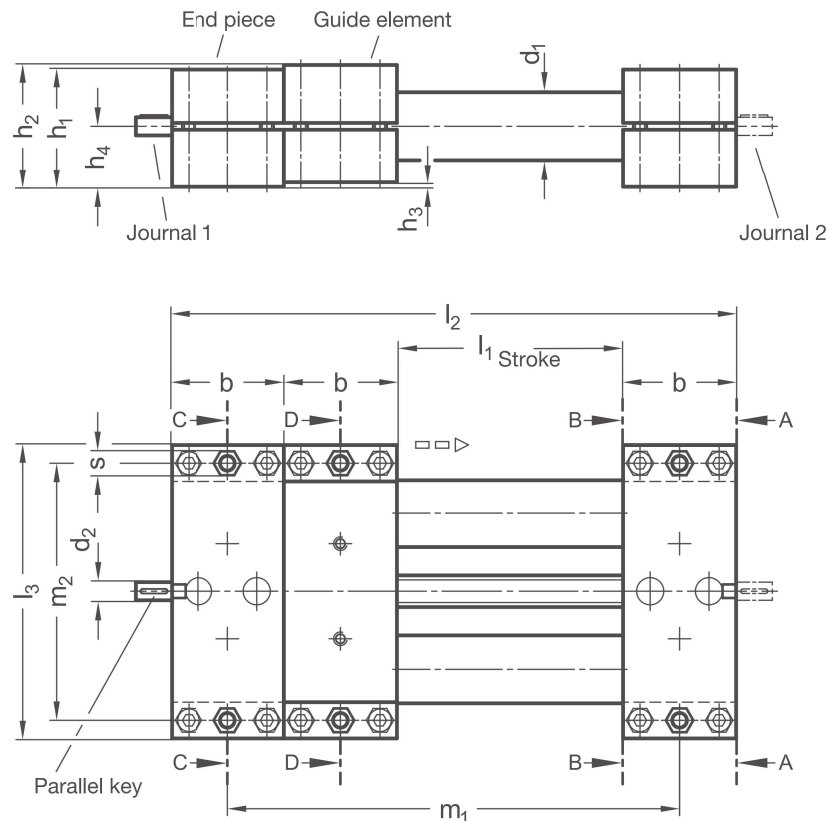

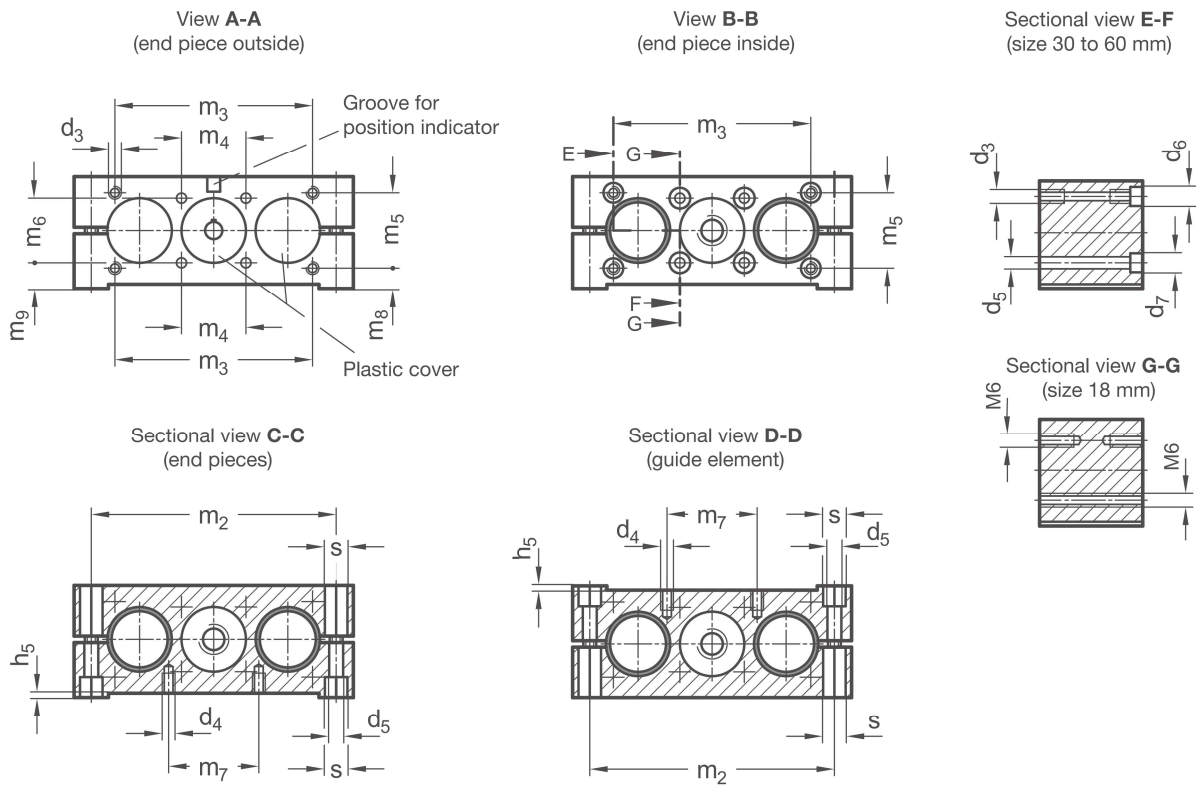

d_1	Stroke l_1	b	d_2	d_3^*	d_4^{**}	d_5	d_6	For screws DIN 912	d_7	For screws DIN 912	h_1	h_2
18	...420	28	6	-	M 5	5,3	-	-	-	-	28	29
30	...1500	50	8	M 6	M 6	6,5	9	M 5	10,5	M 6	52	54
40	...2650	60	12	M 8	M 8	8,5	13,5	M 6	13,5	M 8	60	63
50	...2760	72	12	M 10	M 8	8,5	13,5	M 8	13,5	M 8	72	76
60	...2740	80	14	M 10	M 10	10,5	13,5	M 8	16,5	M 10	86	90

d_1	h_3	h_4	h_5	l_2	l_3	m_1	m_2	m_3	m_4	m_5	m_6	m_7
18	1	14,5	0,75	$3xb+l_1$	81	$2xb+l_1$	68	-	20	-	20	18
30	2	27	0,85	$3xb+l_1$	130	$2xb+l_1$	114	92	30	35	30	42
40	3	31,5	1,05	$3xb+l_1$	180	$2xb+l_1$	160	132	39	38	39	62
50	4	38	1,2	$3xb+l_1$	206	$2xb+l_1$	184	150	46	50	46	62
60	4	45	1,35	$3xb+l_1$	240	$2xb+l_1$	216	185	55	60	55	74

d_1	m_8	m_9	s	Accessories:					
				Parallel key DIN 6885	Torque support	Clamping plate	Position indicator	Handwheel	
18	-	4,5	8	A2x2x12	VZDD	-	VZPM	-	VZH
30	9,5	12	10	A2x2x12	-	VZK	VZPM (only for stroke ≤ 1000 mm)	VZPE	VZH
40	12,5	12	13	A4x4x12	-	VZK	VZPM	VZPE	VZH
50	13	15	13	A4x4x12	-	VZK	VZPM	VZPE	VZH
60	14	16,5	17	A5x5x16	-	VZK	VZPM (only for trapezoidal thread)	VZPE	VZH

* usable thread depth on both sides min. $2 \times d_3$ ** usable thread depth min. $1,5 \times d_4$

Material
W

ST	Aluminum - steel • Guide tubes: Steel, chrome-plated • End pieces / guide elements: Aluminum, bright. Assembly surfaces: Machined • Trapezoidal / fine thread spindle: Steel, with ball bearing	STS	Aluminum - steel • Guide tubes: Steel, chrome-plated • End pieces / guide elements: Aluminum, powder-coated, Black RAL 9005, Assembly surfaces: Machined bright • Trapezoidal / fine thread spindle: Steel, with ball bearing
ED	Aluminum - stainless steel • Guide tubes: Stainless steel AISI 304, polished • End pieces / guide elements: Aluminum, bright. Assembly surfaces: Machined • Trapezoidal / fine thread spindle: Stainless steel AISI 303, with ball bearing	EDS	Aluminum - stainless steel • Guide tubes: Stainless steel AISI 304, polished • End pieces / guide elements: Aluminum, powder-coated, Black RAL 9005, Assembly surfaces: Machined bright • Trapezoidal / fine thread spindle: Stainless steel AISI 303, with ball bearing

Spindle thread direction
r

RH	Right-hand thread
LH	Left-hand thread

d_1	Spindle \varnothing	Spindle pitch p		Journal diameter d_2	Journal length B l_4	Journal length C l_5	Journal length D l_6	Journal length E l_7	Journal length F l_8	Individual journal length l_9
		Trapezoidal thread	Fine thread, metric							
18	10	3	1	6	16	30	46	-	-	16...46
30	14	4	1	8	16	36	52	31	67	16...67
40	20	4	1	12	17	42	59	32	74	17...74
50	20	4	1	12	18	42	60	33	75	18...75
60	24	5	1,5	14	19	42	61	34	76	19...76

Journal
Z₁

B	Journal for handwheel	D	Journal for position indicator and handwheel (torque support required for $d_1 = 18$)	E	Journal for spacer plate and handwheel (only for $d_1 \geq 30$)
<p>Journal length l_4</p>		<p>Journal length l_6</p>		<p>Journal length l_7</p>	
F	Journal for spacer plate, position indicator und handwheel (only for $d_1 \geq 30$)	Gxx	Individual journal length with keyway (for xx, enter values from column l_9)	Hxx	Individual journal length without keyway (for xx, enter values from column l_9)
<p>Journal length l_8</p>		<p>Journal length l_9</p>		<p>Journal length l_9</p>	

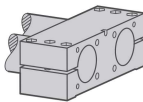
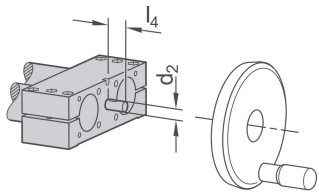
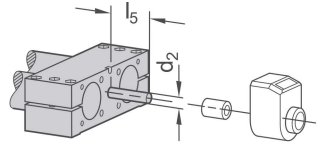
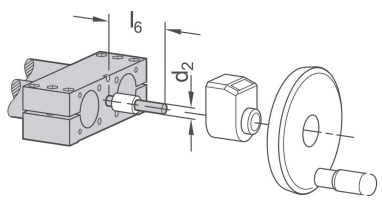
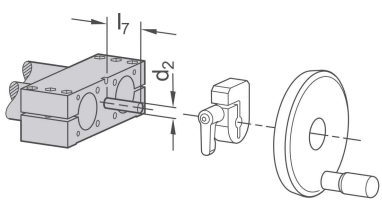
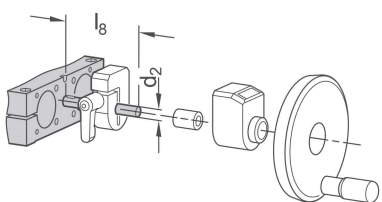
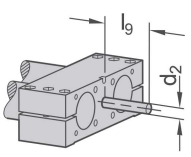
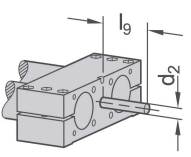
Journal z_2					
A	Without journal	B	Journal for handwheel	C	Journal for position indicator (torque support required for $d_1=18$)
					
Journal length l_4		Journal length l_5			
D	Journal for position indicator and handwheel (torque support required for $d_1=18$)	E	Journal for spacer plate and handwheel (only for $d_1 \geq 30$)	F	Journal for spacer plate, position indicator and handwheel (only for $d_1 \geq 30$)
					
Journal length l_6		Journal length l_7		Journal length l_8	
Gxx	Individual journal length with keyway (for xx, enter values from column l_9)	Hxx	Individual journal length without keyway (for xx, enter values from column l_9)		
					
Journal length l_9		Journal length l_9			

ORDER KEY

Name key	Supplemental key
VD1E - d₁ - w - l₁ - r - p - z₁ - z₂	

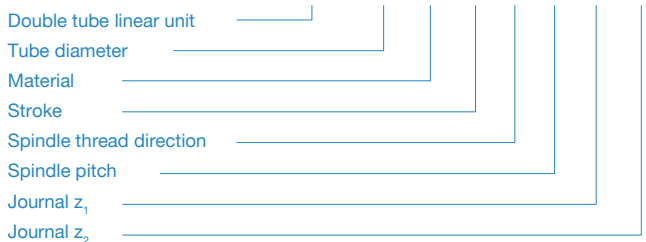

ACCESSORIES

- Handwheels **VZH** → see page 356
- Position indicators **VZPM / VZPE** → see page 358 / 360
- Clamping plates **VZK** → see page 362
- Torque supports **VZDD** → see page 368
- Angle gears **YLD** → see page 378
- Transfer units **VA** → see page 370

ON REQUEST

- Additional following guide elements
- Guide element connector plates
- Multiple guide elements with scissors synchronization
- Bellows covers