



### PRODUCT INFO

The guide tubes of the **double tube linear units VD2E** are made of chrome-plated steel or polished stainless steel precision tubes. The aluminum end pieces connect the tubes and form a solid linear guide together with the two guide elements. A continuous spindle with ball bearings on both sides is installed in the center. This is comprised of one spindle part with left-hand thread and one with right-hand thread. Together with the single guide elements, the affixed spindle nuts move linearly in opposing directions along the spindle thread.

Double tube linear units have high torsional stiffness and can handle high weights and torques. Depending on the design, the part to be moved is fastened to the guide element or the guide element itself is installed at the place of use such that the entire linear unit moves together.

Possible accessories are already taken into account in the selection of the linear units according to the options given in the tables. This ensures, for example, that the journal lengths  $z_1$  and  $z_2$  are appropriate for attachment of the accessories. The accessories are not included with the linear units.

### RoHS-compliant product

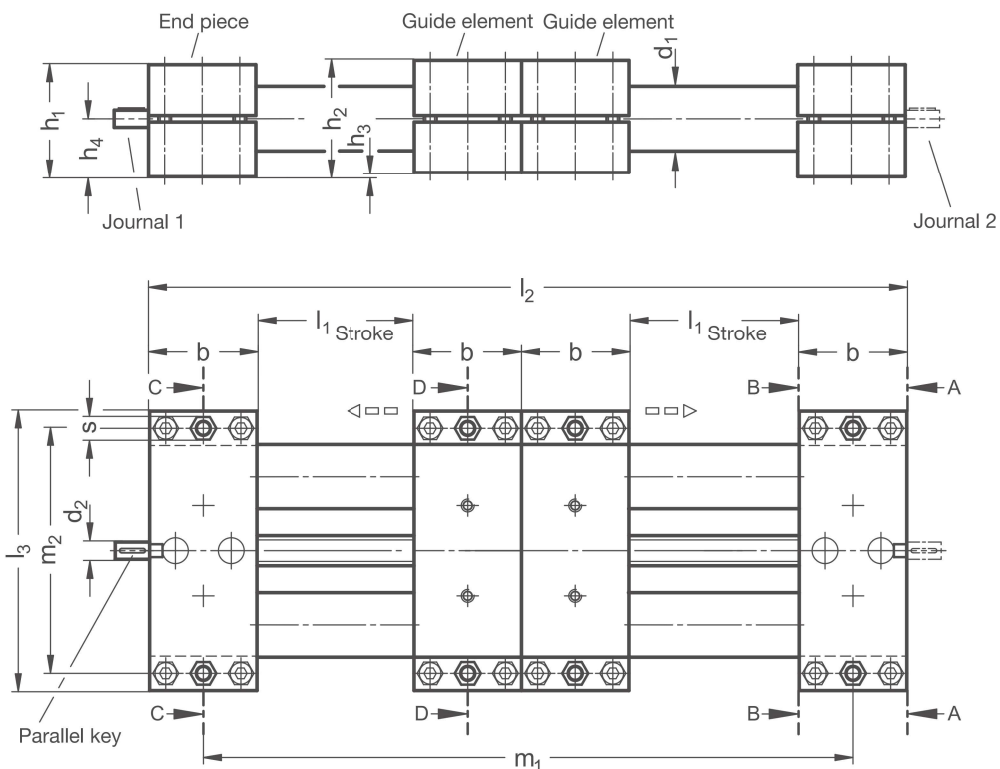

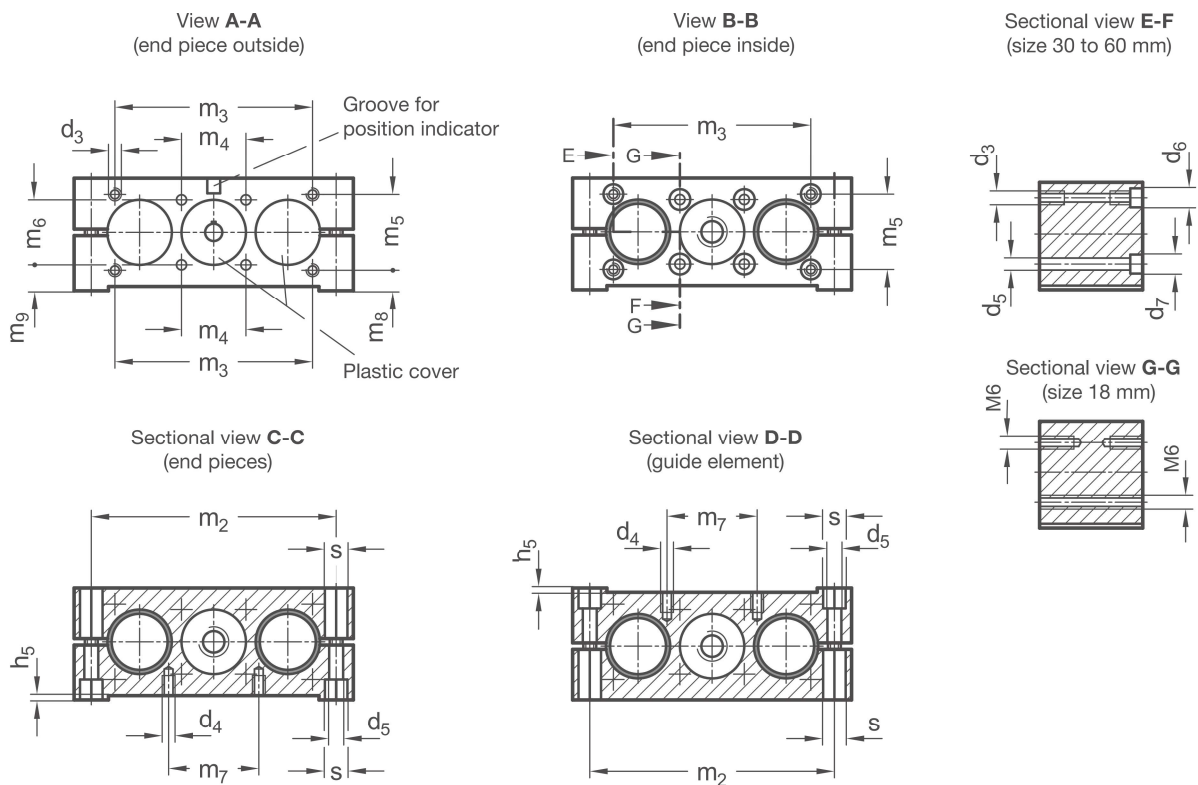

$d_1$	Stroke $l_1$	$b$	$d_2$	$d_3^*$	$d_4^{**}$	$d_5$	$d_6$	For screws DIN 912	$d_7$	For screws DIN 912	$h_1$	$h_2$
18	...420	28	6	-	M 5	5,3	-	-	-	-	28	29
30	...750	50	8	M 6	M 6	6,5	9	M 5	10,5	M 6	52	54
40	...1250	60	12	M 8	M 8	8,5	13,5	M 6	13,5	M 8	60	63
50	...1300	72	12	M 10	M 8	8,5	13,5	M 8	13,5	M 8	72	76
60	...1350	80	14	M 10	M 10	10,5	13,5	M 8	16,5	M 10	86	90

$d_1$	$h_3$	$h_4$	$h_5$	$l_2$	$l_3$	$m_1$	$m_2$	$m_3$	$m_4$	$m_5$	$m_6$	$m_7$
18	1	14,5	0,75	$4xb+2xl_1$	81	$3xb+2xl_1$	68	-	20	-	20	18
30	2	27	0,85	$4xb+2xl_1$	130	$3xb+2xl_1$	114	92	30	35	30	42
40	3	31,5	1,05	$4xb+2xl_1$	180	$3xb+2xl_1$	160	132	39	38	39	62
50	4	38	1,2	$4xb+2xl_1$	206	$3xb+2xl_1$	184	150	46	50	46	62
60	4	45	1,35	$4xb+2xl_1$	240	$3xb+2xl_1$	216	185	55	60	55	74

$d_1$	$m_8$	$m_9$	$s$	Accessories:					
				Parallel key DIN 6885	Torque support	Clamping plate	Position indicator	Handwheel	
18	-	4,5	8	A2x2x12	VZDD	-	VZPM	-	VZH
30	9,5	12	10	A2x2x12	-	VZK	VZPM (only for stroke $\leq$ 1000 mm)	VZPE	VZH
40	12,5	12	13	A4x4x12	-	VZK	VZPM	VZPE	VZH
50	13	15	13	A4x4x12	-	VZK	VZPM	VZPE	VZH
60	14	16,5	17	A5x5x16	-	VZK	VZPM (only for trapezoidal thread)	VZPE	VZH

\* usable thread depth on both sides min.  $2 \times d_3$  \*\* usable thread depth min.  $1,5 \times d_4$

Material  
W

ST	Aluminum - steel • Guide tubes: Steel, chrome-plated • End pieces / guide elements: Aluminum, bright. Assembly surfaces: Machined • Trapezoidal / fine thread spindle: Steel, with ball bearing	STS	Aluminum - steel • Guide tubes: Steel, chrome-plated • End pieces / guide elements: Aluminum, powder-coated, Black RAL 9005, Assembly surfaces: Machined bright • Trapezoidal / fine thread spindle: Steel, with ball bearing
ED	Aluminum - stainless steel • Guide tubes: Stainless steel AISI 304, polished • End pieces / guide elements: Aluminum, bright. Assembly surfaces: Machined • Trapezoidal / fine thread spindle: Stainless steel AISI 303, with ball bearing	EDS	Aluminum - stainless steel • Guide tubes: Stainless steel AISI 304, polished • End pieces / guide elements: Aluminum, powder-coated, Black RAL 9005, Assembly surfaces: Machined bright • Trapezoidal / fine thread spindle: Stainless steel AISI 303, with ball bearing

Spindle thread direction  
r

RH	Right-hand thread
LH	Left-hand thread

d <sub>1</sub>	Spindle Ø	Spindle pitch p		Journal diameter d <sub>2</sub>	Journal length B l <sub>4</sub>	Journal length C l <sub>5</sub>	Journal length D l <sub>6</sub>	Journal length E l <sub>7</sub>	Journal length F l <sub>8</sub>	Individual journal length l <sub>9</sub>
		Trapezoidal thread	Fine thread, metric							
18	10	3	1	6	16	30	46	-	-	16...46
30	14	4	1	8	16	36	52	31	67	16...67
40	20	4	1	12	17	42	59	32	74	17...74
50	20	4	1	12	18	42	60	33	75	18...75
60	24	5	1,5	14	19	42	61	34	76	19...76

Journal  
Z<sub>1</sub>

B	Journal for handwheel	D	Journal for position indicator and handwheel (torque support required for d <sub>1</sub> = 18)	E	Journal for spacer plate and handwheel (only for d <sub>1</sub> ≥ 30)
<p>Journal length l<sub>4</sub></p>		<p>Journal length l<sub>6</sub></p>		<p>Journal length l<sub>7</sub></p>	
F	Journal for spacer plate, Position indicator und handwheel (only for d <sub>1</sub> ≥ 30)	Gxx	Individual journal length with keyway (for xx, enter values from column l <sub>9</sub> )	Hxx	Individual journal length without keyway (for xx, enter values from column l <sub>9</sub> )
<p>Journal length l<sub>8</sub></p>		<p>Journal length l<sub>9</sub></p>		<p>Journal length l<sub>9</sub></p>	

Journal $Z_2$	
A	Without journal
B	Journal for handwheel
C	Journal for position indicator (torque support required for $d_1=18$ )
D	Journal for position indicator and handwheel (torque support required for $d_1=18$ )
E	Journal for spacer plate and handwheel (only for $d_1 \geq 30$ )
F	Journal for spacer plate, position indicator and handwheel (only for $d_1 \geq 30$ )
Gxx	Individual journal length with keyway (for xx, enter values from column $I_9$ )
Hxx	Individual journal length without keyway (for xx, enter values from column $I_9$ )

**ORDER KEY**

Name key | Supplemental key  
**VD2E - d<sub>1</sub> - w - l<sub>1</sub> - r - p - z<sub>1</sub> - z<sub>2</sub>**

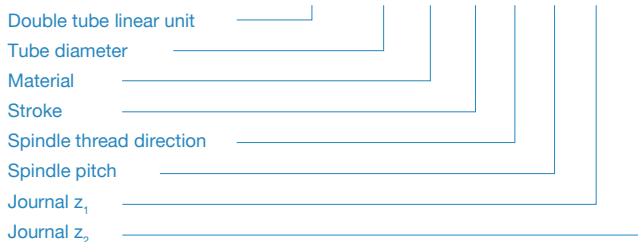

**ACCESSORIES**

- Handwheels **VZH** → see page 356
- Position indicators **VZPM / VZPE** → see page 358 / 360
- Clamping plates **VZK** → see page 362
- Torque supports **VZDD** → see page 368
- Angle gears **YLD** → see page 378
- Transfer units **VA** → see page 370

**ON REQUEST**

- Additional following guide elements
- Guide element connector plates
- Multiple guide elements with scissors synchronization
- Bellows covers