

### PRODUCT INFO

The tubes of the **telescope linear units VT1W** are made of chrome-plated steel or bright, seamless stainless steel precision tubes. A continuous spindle with ball bearings on each side is installed in the guide tube. The attached spindle nut transmits the linear movements to the telescope tube, initiating an adjustment of the telescope linear unit travel distance.

The guide tube is fitted with sliding inserts and forms a solid linear round guide together with the telescope tube. The linear unit can be adjusted for low backlash or clamped in place via the slitted guide sleeve. The drive is offset by 90 degrees by means of an angle gear, allowing the telescope linear unit to be fastened at the end. Depending on the type of fastening, the drive of the linear unit remains at the fastening point or is carried along by the travel movement.

Accessory parts are listed in the tables and are already taken into account when selecting the linear units. This ensures that the length of the shaft journal  $z$  is correct for attachment of the accessories, for example. The accessories are not included with the linear units and must be ordered separately.

**RoHS-compliant product**



2A

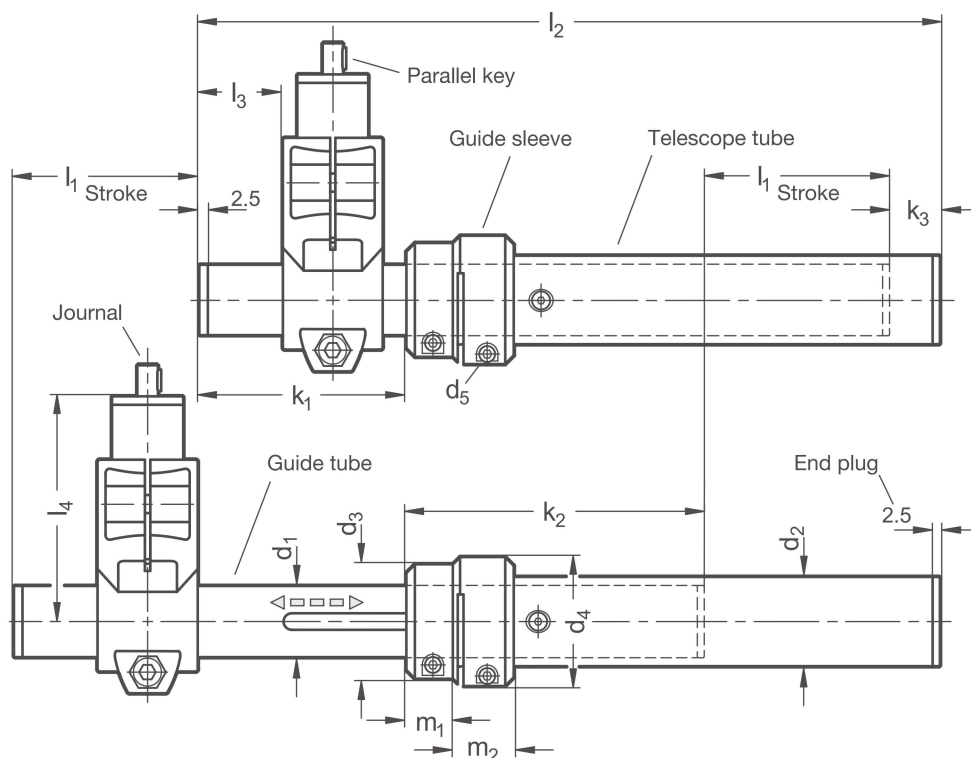

<b>d<sub>1</sub></b>	Stroke max. <b>l<sub>1</sub></b>	Edge distance 1 min. <b>k<sub>1</sub></b>	Guide length min. <b>k<sub>2</sub></b>	Edge distance 2 min. <b>k<sub>3</sub></b>	<b>d<sub>2</sub></b>	<b>d<sub>3</sub></b>	<b>d<sub>4</sub></b>	<b>d<sub>5</sub></b>	Total length max. (retracted) ( <b>k<sub>1</sub> + k<sub>2</sub> + l<sub>1</sub> + k<sub>3</sub></b> ) <b>l<sub>2</sub></b>	<b>l<sub>3</sub></b>	<b>l<sub>4</sub></b>	<b>m<sub>1</sub></b>	<b>m<sub>2</sub></b>
30	...400	120	73	12	35	49	54	M 5	1000	70	86	15	21
40	...600	156	94	12	50	64	72	M 6	1400	90	125	26	34

**Material**  
**w**

ST	Steel • Guide tube, DIN EN 10305-4: Steel, chrome-plated • Trapezoidal / fine thread spindle: Steel, with ball bearing • Spindle nut: Red brass / end plug: Plastic / Guide sleeve: Aluminum
ED	Stainless steel • Guide tubes, EN 10216-5: Stainless steel AISI 304 • Trapezoidal / fine thread spindle: Stainless steel AISI 303, with ball bearing • Spindle nut: Red brass / end plug: Plastic / Guide sleeve: Aluminum

**Spindle thread direction**  
**r**

RH	Right-hand thread
LH	Left-hand thread

<b>d<sub>1</sub></b>	Spindle <b>∅</b>	Spindle pitch <b>p</b>		Journal diameter <b>d<sub>6</sub></b>	Journal length <b>l<sub>5</sub></b>	Journal length <b>l<sub>6</sub></b>	Journal length <b>l<sub>7</sub></b>	Journal length <b>l<sub>8</sub></b>	individual journal length <b>l<sub>9</sub></b>
		Trapezoidal thread	Fine thread, metric						
30	14	4	1	8	16	52	31	67	16...67
40	20	4	1	12	17	59	32	74	17...74

**Accessories:**

<b>d<sub>1</sub></b>	Torque support	Clamping plate	Position indicator	Handwheel
30	VZDR	VZK	VZPM	VZPE
40	VZDR	VZK	VZPM	VZPE

Journal  
**Z**

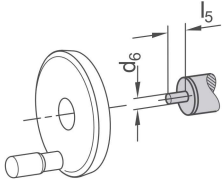
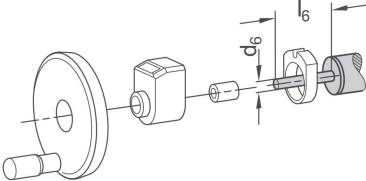
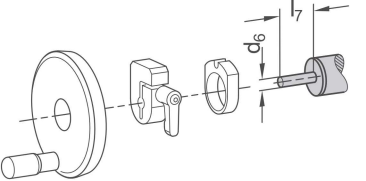
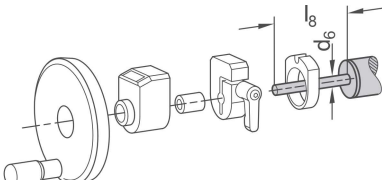
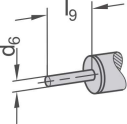
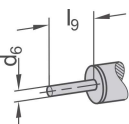
<p><b>B</b> Journal for handwheel</p>	<p><b>D</b> Journal for position indicator and handwheel</p>	<p><b>E</b> Journal for spacer plate and handwheel</p>
 <p>Journal length <math>l_5</math></p>	 <p>Journal length <math>l_6</math></p>	 <p>Journal length <math>l_7</math></p>
<p><b>F</b> Journal for spacer plate, position indicator and handwheel</p>	<p><b>Gxx</b> Individual length with keyway (for xx enter value from column <math>l_9</math>)</p>	<p><b>Hxx</b> Individual length without keyway (for xx enter value from column <math>l_9</math>)</p>
 <p>Journal length <math>l_8</math></p>	 <p>Journal length <math>l_9</math></p>	 <p>Journal length <math>l_9</math></p>

2A

**ACCESSORIES**

- Handwheels **VZH** → see page 356
- Position indicators **VZPM / VZPE** → see page 358 / 360
- Clamping plates **VZK** → see page 362
- Torque supports **VZDR** → see page 364

**ORDER KEY**

Name key	Supplemental key
<b>VT1W - d<sub>1</sub> - w - l<sub>1</sub> - k<sub>1</sub> - k<sub>2</sub> - k<sub>3</sub> - r - p - z</b>	

