

7.4 LGBCH...B / LGBCX...B

Linear guide with ball chain, carriages in block design, in normal / medium design height

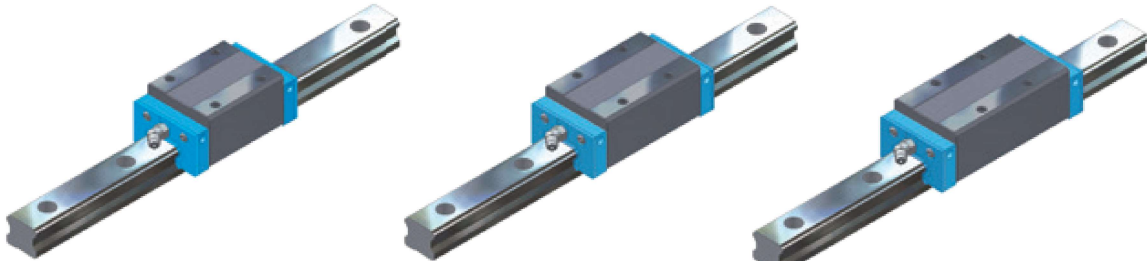

LGBCH / LGBCX...BN (standard)

LGBCH / LGBCX...BL (long)

LGBCH / LGBCX...BE (extra long)

Example of order code

LGBCH 25 BN 2 SS L 02000 N Z1 - 2 - 0 -20.0 N*

*Explanation to type code in Chapter 8

		System mm					Carriage mm											
		H	W	W2	E	L	B	J	MQ	I	L1	H2	T1	N	T2	L2	H3	Lx
LGBCH15	BN	28	34	9,5	3,4	58,6	26	26	M 4	6,0	40,2	M 3 x 0,5	9,5	5,7	8,5	4,20	M 3 x 0,5	3,0
LGBCH20	BN	30	44	12,0	4,5	70,1	32	36	M 5	6,5	48,5	M 6 x 1,0	7,1	12,3	6,3	4,25	M 6 x 1,0	3,8
LGBCH20	BL	30	44	12,0	4,5	82,9	32	36	M 5	6,5	61,3	M 6 x 1,0	7,1	12,3	6,3	4,25	M 6 x 1,0	3,8
LGBCH20	BE	30	44	12,0	4,5	98,1	32	50	M 5	6,5	76,5	M 6 x 1,0	7,1	12,3	6,3	4,25	M 6 x 1,0	3,8
LGBCX25	BN	36	48	12,5	5,8	79,2	35	35	M 6	9,0	57,5	M 6 x 1,0	10,2	12,2	9,4	4,65	M 6 x 1,0	5,0
LGBCX25	BL	36	48	12,5	5,8	93,9	35	35	M 6	9,0	72,2	M 6 x 1,0	10,2	12,2	9,4	4,65	M 6 x 1,0	5,0
LGBCX25	BE	36	48	12,5	5,8	108,6	35	50	M 6	9,0	86,9	M 6 x 1,0	10,2	12,2	9,4	4,65	M 6 x 1,0	5,0
LGBCH25	BN	40	48	12,5	5,8	79,2	35	35	M 6	9,0	57,5	M 6 x 1,0	14,2	12,2	13,4	4,65	M 6 x 1,0	5,0
LGBCH25	BL	40	48	12,5	5,8	93,9	35	35	M 6	9,0	72,2	M 6 x 1,0	14,2	12,2	13,4	4,65	M 6 x 1,0	5,0
LGBCH25	BE	40	48	12,5	5,8	108,6	35	50	M 6	9,0	86,9	M 6 x 1,0	14,2	12,2	13,4	4,65	M 6 x 1,0	5,0
LGBCH30	BN	45	60	16,0	7,0	94,8	40	40	M 8	12,0	67,8	M 6 x 1,0	13,0	11,7	8,5	6,00	M 6 x 1,0	5,0
LGBCH30	BL	45	60	16,0	7,0	105,0	40	40	M 8	12,0	78,0	M 6 x 1,0	13,0	11,7	8,5	6,00	M 6 x 1,0	5,0
LGBCH30	BE	45	60	16,0	7,0	130,5	40	60	M 8	12,0	103,5	M 6 x 1,0	13,0	11,7	8,5	6,00	M 6 x 1,0	5,0
LGBCH35	BN	55	70	18,0	7,5	111,5	50	50	M 8	12,0	80,5	M 6 x 1,0	18,5	11,5	13,5	7,25	M 6 x 1,0	5,0
LGBCH35	BL	55	70	18,0	7,5	123,5	50	50	M 8	12,0	92,5	M 6 x 1,0	18,5	11,5	13,5	7,25	M 6 x 1,0	5,0
LGBCH35	BE	55	70	18,0	7,5	153,5	50	72	M 8	12,0	122,5	M 6 x 1,0	18,5	11,5	13,5	7,25	M 6 x 1,0	5,0
LGBCH45	BN	70	86	20,5	8,9	129,0	60	60	M 10	18,0	94,0	M 8 x 1,25	24,5	10,8	24,5	8,00	M 8 x 1,25	7,5
LGBCH45	BL	70	86	20,5	8,9	145,0	60	60	M 10	18,0	110,8	M 8 x 1,25	24,5	10,8	24,5	8,00	M 8 x 1,25	7,5
LGBCH45	BE	70	86	20,5	8,9	174,0	60	80	M 10	18,0	139,0	M 8 x 1,25	24,5	10,8	24,5	8,00	M 8 x 1,25	7,5
LGBCH55	BN	80	100	23,5	12,7	155,0	75	75	M 12	22,0	116,0	M 8 x 1,25	24,0	10,8	24,5	10,80	M 8 x 1,25	7,5
LGBCH55	BL	80	100	23,5	12,7	193,0	75	75	M 12	22,0	154,0	M 8 x 1,25	24,0	10,8	24,5	10,80	M 8 x 1,25	7,5
LGBCH55	BE	80	100	23,5	12,7	210,8	75	95	M 12	22,0	171,0	M 8 x 1,25	24,0	10,8	24,5	10,80	M 8 x 1,25	7,5

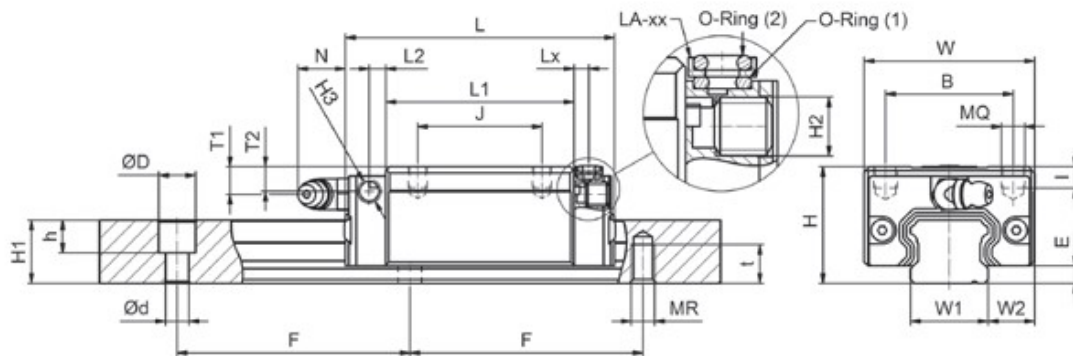
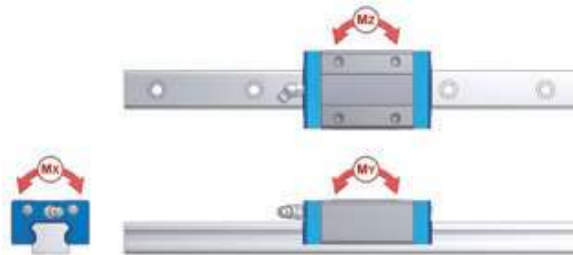

		Rail [mm]						Load rating					Mass			
		Version L			Version C			kN		kNm			kg	kg/ m		
W1	H1	F	d	D	h	MR	t	C	C0	MX	MY	MZ	Carriage	Rail		
15	13,0	60	4,5	7,5	5,5	M 5	8,0	11,67	19,90	0,137	0,120	0,120	0,19	1,28	LGBCH15	BN
20	16,3	60	6,0	9,5	8,5	M 6	10,0	17,98	30,96	0,289	0,224	0,224	0,31	2,15	LGBCH20	BN
20	16,3	60	6,0	9,5	8,5	M 6	10,0	23,30	40,11	0,376	0,366	0,366	0,36	2,15	LGBCH20	BL
20	16,3	60	6,0	9,5	8,5	M 6	10,0	27,85	49,61	0,464	0,565	0,565	0,47	2,15	LGBCH20	BE
23	19,2	60	7,0	11,0	9,0	M 6	12,0	25,25	41,73	0,447	0,358	0,358	0,40	2,88	LGBCH25	BN
23	19,2	60	7,0	11,0	9,0	M 6	12,0	32,44	53,63	0,576	0,577	0,577	0,54	2,88	LGBCH25	BL
23	19,2	60	7,0	11,0	9,0	M 6	12,0	36,58	64,30	0,691	0,833	0,833	0,67	2,88	LGBCH25	BE
23	19,2	60	7,0	11,0	9,0	M 6	12,0	25,25	41,73	0,447	0,358	0,358	0,45	2,88	LGBCH25	BN
23	19,2	60	7,0	11,0	9,0	M 6	12,0	32,44	53,63	0,576	0,577	0,577	0,66	2,88	LGBCH25	BL
23	19,2	60	7,0	11,0	9,0	M 6	12,0	36,58	64,30	0,691	0,833	0,833	0,80	2,88	LGBCH25	BE
28	22,8	80	9,0	14,0	12,0	M 8	15,0	37,33	55,50	0,719	0,560	0,560	0,91	4,45	LGBCH30	BN
28	22,8	80	9,0	14,0	12,0	M 8	15,0	48,35	71,88	0,931	0,836	0,836	1,04	4,45	LGBCH30	BL
28	22,8	80	9,0	14,0	12,0	M 8	15,0	53,83	88,18	1,142	1,361	1,361	1,36	4,45	LGBCH30	BE
34	26,0	80	9,0	14,0	12,0	M 8	17,0	53,31	82,66	1,307	0,991	0,991	1,50	6,25	LGBCH35	BN
34	26,0	80	9,0	14,0	12,0	M 8	17,0	66,61	103,29	1,633	1,424	1,424	1,80	6,25	LGBCH35	BL
34	26,0	80	9,0	14,0	12,0	M 8	17,0	73,29	127,68	2,020	2,330	2,330	2,34	6,25	LGBCH35	BE
45	31,1	105	14,0	20,0	17,0	M 12	20,0	73,14	111,30	2,353	1,559	1,559	2,28	9,60	LGBCH45	BN
45	31,1	105	14,0	20,0	17,0	M 12	20,0	86,99	132,39	2,798	2,170	2,170	2,67	9,60	LGBCH45	BL
45	31,1	105	14,0	20,0	17,0	M 12	20,0	100,52	166,87	3,527	3,455	3,455	3,35	9,60	LGBCH45	BE
53	38,0	120	16,0	23,0	20,0	M 14	24,0	88,26	136,62	3,385	2,361	2,361	3,42	13,80	LGBCH55	BN
53	38,0	120	16,0	23,0	20,0	M 14	24,0	119,10	183,14	4,538	4,202	4,202	4,57	13,80	LGBCH55	BL
53	38,0	120	16,0	23,0	20,0	M 14	24,0	161,43	259,71	6,430	6,617	6,617	5,08	13,80	LGBCH55	BE