

## 7.6 LGBXH...F

### Linear guide without ball chain, carriages in flange design normal design height

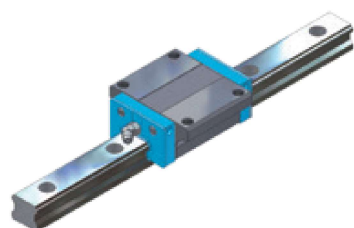

LGBXH...FN, standard



LGBXH...FL, long

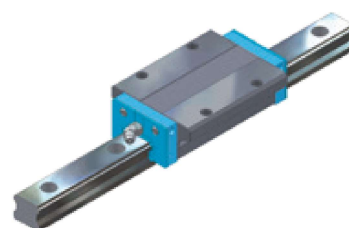

LGBXH...FE, extra long

#### Example of order code

LGBXH 25 FN 2 SS L 02000 N Z1 - 2 - 0 -20.0 N\*

\*Explanation to type code in Chapter 8

		System mm					Carriage mm												
		H	W	W2	E	L	B	J	MQ	ih	I	L1	H2	T1	N	T2	L2	H3	Lx
LGBXH15	FN	24	47	16,0	3,4	58,6	38	30	M 5	4,4	7,5	40,2	M 3 x 0,5	5,5	5,7	4,5	4,20	M 3 x 0,5	3,0
LGBXH15	FL	24	47	16,0	3,4	66,1	38	30	M 5	4,4	7,5	47,7	M 3 x 0,5	5,5	5,7	4,5	4,20	M 3 x 0,5	3,0
LGBXH20	FN	30	63	21,5	4,5	70,1	53	40	M 6	5,4	9,0	48,5	M 6 x 1,0	7,1	12,3	6,3	4,25	M 6 x 1,0	3,8
LGBXH20	FL	30	63	21,5	4,5	82,9	53	40	M 6	5,4	9,0	61,3	M 6 x 1,0	7,1	12,3	6,3	4,25	M 6 x 1,0	3,8
LGBXH20	FE	30	63	21,5	4,5	98,1	53	40	M 6	5,4	9,0	76,5	M 6 x 1,0	7,1	12,3	6,3	4,25	M 6 x 1,0	3,8
LGBXH25	FN	36	70	23,5	5,8	79,2	57	45	M 8	6,8	10,1	57,5	M 6 x 1,0	10,2	12,2	9,4	4,65	M 6 x 1,0	5,0
LGBXH25	FL	36	70	23,5	5,8	93,9	57	45	M 8	6,8	10,1	72,2	M 6 x 1,0	10,2	12,2	9,4	4,65	M 6 x 1,0	5,0
LGBXH25	FE	36	70	23,5	5,8	108,6	57	45	M 8	6,8	10,1	86,9	M 6 x 1,0	10,2	12,2	9,4	4,65	M 6 x 1,0	5,0
LGBXH30	FS	42	90	31,0	7,0	64,2	72	--	M 10	8,6	12,0	37,2	M 6 x 1,0	10,0	11,7	5,5	6,00	M 6 x 1,0	5,0
LGBXH30	FN	42	90	31,0	7,0	94,8	72	52	M 10	8,6	12,0	67,8	M 6 x 1,0	10,0	11,7	5,5	6,00	M 6 x 1,0	5,0
LGBXH30	FL	42	90	31,0	7,0	105,0	72	52	M 10	8,6	12,0	78,0	M 6 x 1,0	10,0	11,7	5,5	6,00	M 6 x 1,0	5,0
LGBXH30	FE	42	90	31,0	7,0	130,5	72	52	M 10	8,6	12,0	103,5	M 6 x 1,0	10,0	11,7	5,5	6,00	M 6 x 1,0	5,0
LGBXH35	FS	48	100	33,0	7,5	75,5	82	--	M 10	8,6	14,0	44,5	M 6 x 1,0	11,5	11,5	10,5	7,25	M 6 x 1,0	5,0
LGBXH35	FN	48	100	33,0	7,5	111,5	82	62	M 10	8,6	14,0	80,5	M 6 x 1,0	11,5	11,5	10,5	7,25	M 6 x 1,0	5,0
LGBXH35	FL	48	100	33,0	7,5	123,5	82	62	M 10	8,6	14,0	92,5	M 6 x 1,0	11,5	11,5	10,5	7,25	M 6 x 1,0	5,0
LGBXH35	FE	48	100	33,0	7,5	153,5	82	62	M 10	8,6	14,0	122,5	M 6 x 1,0	11,5	11,5	10,5	7,25	M 6 x 1,0	5,0
LGBXH45	FN	60	120	37,5	8,9	129,0	100	80	M 12	10,6	16,0	94,0	M 8 x 1,25	14,4	10,8	14,5	8,00	M 8 x 1,25	7,5
LGBXH45	FL	60	120	37,5	8,9	145,0	100	80	M 12	10,6	16,0	110,0	M 8 x 1,25	14,4	10,8	14,5	8,00	M 8 x 1,25	7,5
LGBXH45	FE	60	120	37,5	8,9	174,0	100	80	M 12	10,6	16,0	139,0	M 8 x 1,25	14,4	10,8	14,5	8,00	M 8 x 1,25	7,5
LGBXH55	FN	70	140	43,5	12,7	155,0	116	95	M 14	12,6	19,0	116,0	M 8 x 1,25	14,0	10,8	14,5	10,00	M 8 x 1,25	7,5
LGBXH55	FL	70	140	43,5	12,7	193,0	116	95	M 14	12,6	19,0	154,0	M 8 x 1,25	14,0	10,8	14,5	10,00	M 8 x 1,25	7,5
LGBXH55	FE	70	140	43,5	12,7	210,0	116	95	M 14	12,6	19,0	171,0	M 8 x 1,25	14,0	10,8	14,5	10,00	M 8 x 1,25	7,5

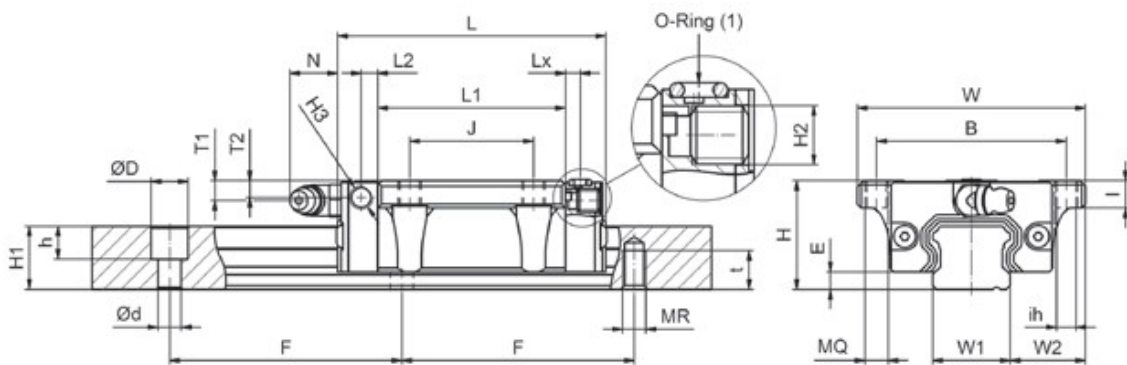
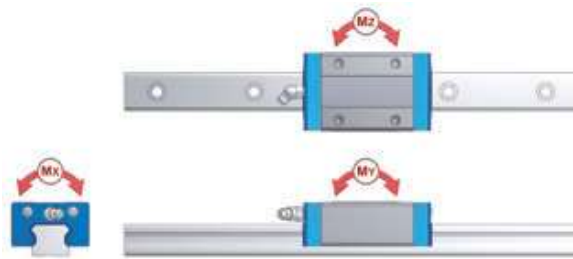

Rail [mm]								Load rating					Mass		LGBXH	FN
W1	H1	F	Version L			Version C		kN		kNm			Carriage	Rail		
			d	D	h	MR	t	C	C0	MX	MY	MZ				
15	13	60	4,5	7,5	5,5	M 5	8,0	9,46	19,90	0,137	0,120	0,120	0,21	1,28	LGBXH15	FN
15	13	60	4,5	7,5	5,5	M 5	8,0	11,39	24,05	0,166	0,171	0,171	0,23	1,28	LGBXH15	FL
20	16,3	60	6,0	9,5	8,5	M 6	10,0	14,56	30,96	0,289	0,224	0,224	0,40	2,15	LGBXH20	FN
20	16,3	60	6,0	9,5	8,5	M 6	10,0	18,88	40,11	0,376	0,366	0,366	0,46	2,15	LGBXH20	FL
20	16,3	60	6,0	9,5	8,5	M 6	10,0	22,45	49,61	0,464	0,565	0,565	0,61	2,15	LGBXH20	FE
23	19,2	60	7,0	11,0	9,0	M 6	12,0	20,44	41,73	0,447	0,358	0,358	0,57	2,88	LGBXH25	FN
23	19,2	60	7,0	11,0	9,0	M 6	12,0	26,28	53,63	0,576	0,577	0,577	0,72	2,88	LGBXH25	FL
23	19,2	60	7,0	11,0	9,0	M 6	12,0	29,63	64,30	0,691	0,833	0,833	0,89	2,88	LGBXH25	FE
28	22,8	80	9,0	14,0	12,0	M 8	15,0	14,99	27,51	0,356	0,153	0,153	0,80	4,45	LGBXH30	FS
28	22,8	80	9,0	14,0	12,0	M 8	15,0	30,24	55,50	0,719	0,560	0,560	1,10	4,45	LGBXH30	FN
28	22,8	80	9,0	14,0	12,0	M 8	15,0	39,16	71,88	0,931	0,836	0,836	1,34	4,45	LGBXH30	FL
28	22,8	80	9,0	14,0	12,0	M 8	15,0	43,60	88,18	1,142	1,361	1,361	1,66	4,45	LGBXH30	FE
34	26,0	80	9,0	14,0	12,0	M 8	17,0	21,64	41,43	0,655	0,275	0,275	1,00	6,25	LGBXH35	FS
34	26,0	80	9,0	14,0	12,0	M 8	17,0	44,19	82,66	1,307	0,991	0,991	1,50	6,25	LGBXH35	FN
34	26,0	80	9,0	14,0	12,0	M 8	17,0	53,96	103,29	1,633	1,424	1,424	1,90	6,25	LGBXH35	FL
34	26,0	80	9,0	14,0	12,0	M 8	17,0	59,37	127,68	2,020	2,330	2,330	2,54	6,25	LGBXH35	FE
45	31,1	105	14,0	20,0	17,0	M 12	20,0	59,25	111,30	2,353	1,559	1,559	2,27	9,60	LGBXH45	FN
45	31,1	105	14,0	20,0	17,0	M 12	20,0	70,47	132,39	2,798	2,170	2,170	2,68	9,60	LGBXH45	FL
45	31,1	105	14,0	20,0	17,0	M 12	20,0	81,42	166,87	3,527	3,455	3,455	3,42	9,60	LGBXH45	FE
53	38,0	120	16,0	23,0	20,0	M 14	24,0	71,49	136,62	3,385	2,361	2,361	3,44	13,80	LGBXH55	FN
53	38,0	120	16,0	23,0	20,0	M 14	24,0	96,46	183,14	4,538	4,202	4,202	4,63	13,80	LGBXH55	FL
53	38,0	120	16,0	23,0	20,0	M 14	24,0	130,76	259,71	6,430	6,617	6,617	5,16	13,80	LGBXH55	FE