

7.12 LGMX...B

Miniature guide without ball chain narrow version

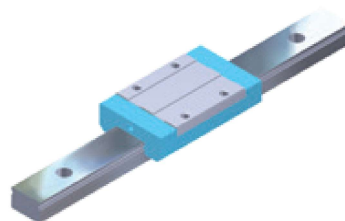

LGMX...BN, narrow version, standard



LGMX...BL, narrow version, long

Example of order code

LGMX 12 BN 2 BB L 00195 N Z1 - 2 - 0 -10.0 N*

*Explanation to type code in Chapter 8

		System mm					Carriage mm							
		H	W	W2	E	L	B	J	MQ	I	L1	H2	T1	N
LGMX07	BN	8	17	5,0	1,5	24,0	12	8	M 2	2,0	13,0	Ø 1,1	1,7	--
LGMX09	BN	10	20	5,5	2,2	30,8	15	10	M 3	2,8	19,5	Ø 1,5	2,4	--
LGMX09	BL	10	20	5,5	2,2	40,5	15	16	M 3	2,8	29,2	Ø 1,5	2,4	--
LGMX12	BN	13	27	7,5	2,0	34,0	20	15	M 3	3,2	20,3	Ø 2,0	3,0	--
LGMX12	BL	13	27	7,5	2,0	47,0	20	20	M 3	3,2	33,3	Ø 2,0	3,0	--
LGMX15	BN	16	32	8,5	4,0	42,0	25	20	M 3	3,5	25,3	M 3 x 0,5	3,5	5
LGMX15	BL	16	32	8,5	4,0	59,8	25	25	M 3	3,5	43,1	M 3 x 0,5	3,5	5

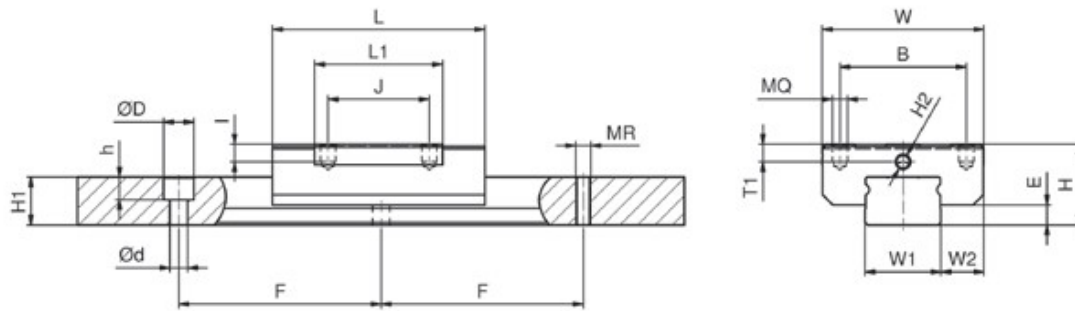
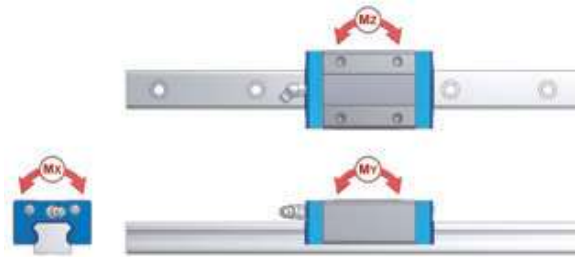

		Rail [mm]								kN		Load rating kNm			Mass		
W1	H1	F	WH	Version L			Version C		C	C0	MX	MY	MZ	Carriage	Rail		
				d	D	h	MR	t									
7	4,70	15	--	2,4	4,4	2,40	M 3	4,70	1,30	1,52	0,0050	0,0031	0,0031	0,010	0,25	LGMX07 BN	
9	6,05	20	--	3,5	6,0	3,30	M 4	6,05	2,03	2,28	0,0105	0,0084	0,0084	0,014	0,39	LGMX09 BN	
9	6,05	20	--	3,5	6,0	3,30	M 4	6,05	2,78	3,28	0,0149	0,0169	0,0169	0,020	0,39	LGMX09 BL	
12	7,25	25	--	3,5	6,0	4,30	M 4	7,25	3,32	3,46	0,0228	0,0118	0,0118	0,029	0,63	LGMX12 BN	
12	7,25	25	--	3,5	6,0	4,30	M 4	7,25	4,46	5,21	0,0337	0,0278	0,0278	0,047	0,63	LGMX12 BL	
15	9,50	40	--	3,5	6,0	4,50	M 5	9,50	5,51	5,66	0,0397	0,0258	0,0258	0,047	1,05	LGMX15 BN	
15	9,50	40	--	3,5	6,0	4,50	M 5	9,50	7,25	7,94	0,0556	0,0546	0,0546	0,078	1,05	LGMX15 BL	