

ATR 06 // Cable drums

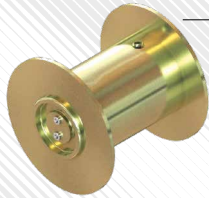

ATR 06.6001



ATR 06.5401



ATR 06.9201



ATR 06.5410



GBA 20.50

ATR 06.6002
ATR 06.6003

ATR 06.5403

- Cable drums and belt drum for power drives and manual drives with output shaft We 06 (ø 26 mm, with transverse bore), with screw M 10 for mounting on shaft.
- Cable diameter $D \varnothing = 4.0\text{--}6.0$ mm ($F = \text{max. } 5000$ N).
- ATR 06.5403 can be used on left as well as right sides of drive unit.
- Belt width $B = 50$ mm ($F = \text{max. } 5000$ N).
- Other cable drums on request.

Note:

- Cable not included in scope of supply.
- Detail H without two safety windings.

Version	Type no.	DR [mm]	DIN 3069 D ø [mm]	H1 [m]	H2 [m]	Rolling method	m [kg]
ATR 06.6001	81006.6001.01	60	5-6	2,3	5,7	smooth	2,1
ATR 06.5401	81006.5401.01	54	4-5	2,6	6,2	smooth	0,7
ATR 06.5410	81006.5401.10	54	-	-	-	smooth	0,7
ATR 06.9201	81006.9201.01	120	6	3,5	-	smooth	2,5
ATR 06.6002	81006.6002.01	61	5	2,4	6,0	grooved/left	2,3
ATR 06.6003	81006.6003.01	61	5	2,4	6,0	grooved/right	2,3
ATR 06.5403	81006.5403.02	54	5	2,8	6,9	grooved/left	0,9

Version	Type no.	B [mm]	L [mm]	m [kg]
GBA 20.5010	81520.5010.0110	50	1000	0,2
GBA 20.5025	81520.5010.0125	50	2500	0,3

ATR 06.6001

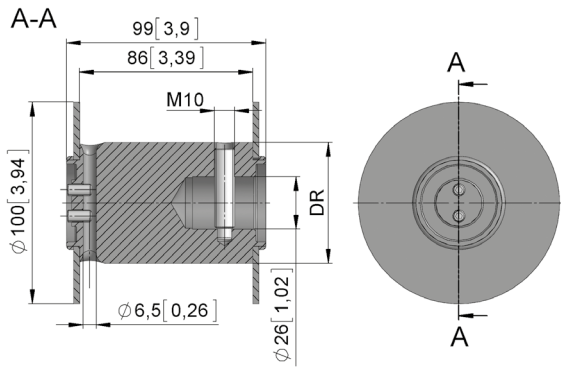

ATR 06.5401

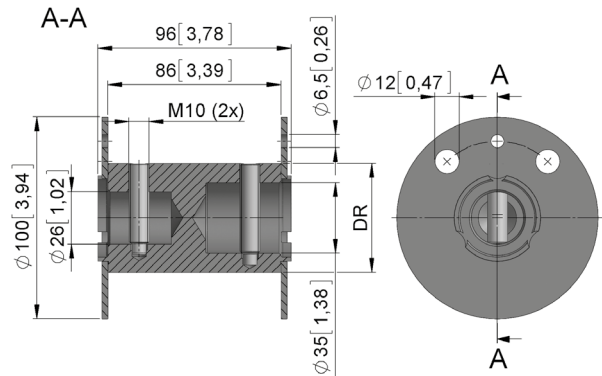

ATR 06.9201

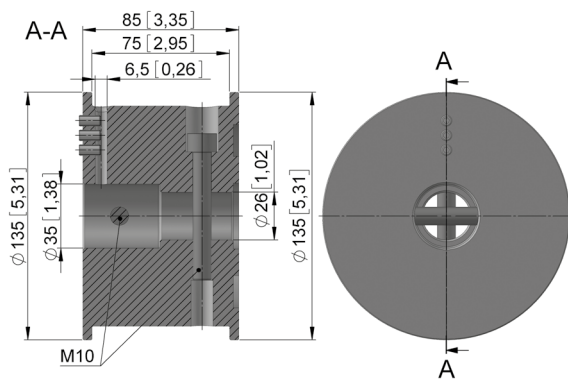

ATR 06.5410

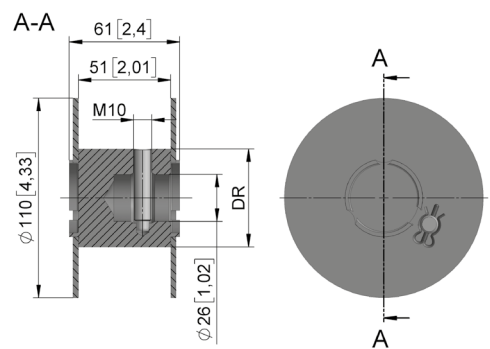

ATR 06.6002 // ATR 06.6003

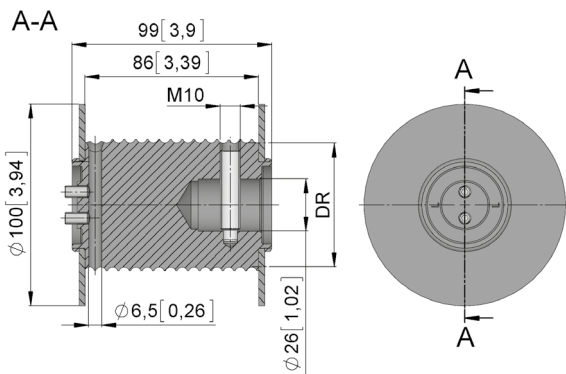

ATR 06.5403

