

BKS 45 // Bush coupling



- Coupling without angle adjustment with axial mounting to transmit torques from power drives and manual drives to 1" and 5/4" adapter tubes.
- BKS 45.06 for round shaft We 06, axially secured by transverse screw. BKS 45.66 for hexagonal shaft We 66, axially secured by retaining ring (i.e. circlip).
- Galvanised steel coupling, two bores for M10 screws to secure the adapter tube, supplied as a complete unit with screws and retaining ring (i.e. circlip).

Note:

- Possible to remove drive unit after unfastening the axial shaft retainers. For this, comply with maximum insertion depth of 65 mm for the adapter tube!

BKS 45.06

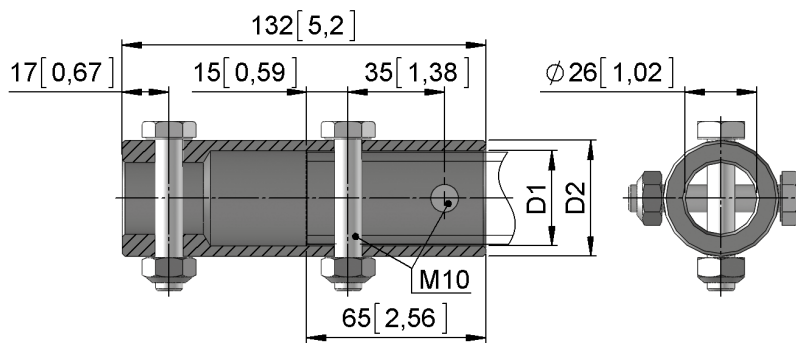

BKS 45.66

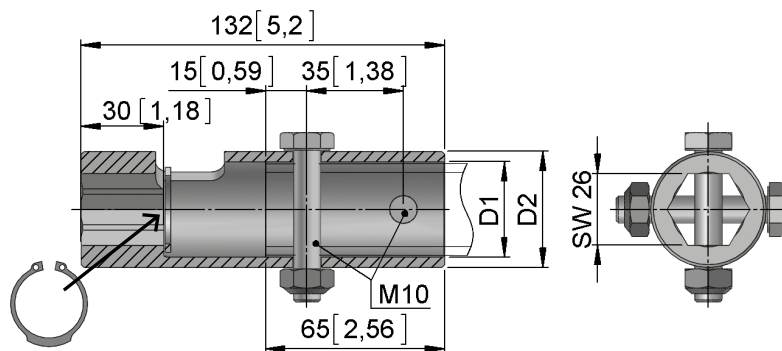

mm [inch]

Version	We 06	We 66	T max [Nm]	D1 [mm]	D2 [mm]	Tube ø [mm]	m [kg]
	Type no.	Type no.					
BKS 45.0634	20745.0601.34	-	200	34,5	42	1"	0,6
BKS 45.6634	-	20745.6621.3430	300	34,5	42	1"	0,6
BKS 45.0643	20745.0601.43	-	200	43,0	52	5/4"	1,0
BKS 45.6643	-	20745.6621.4330	300	43,0	52	5/4"	1,0