

GKN 01, GKN 04 // Articulated couplings



- Universal joint for transmission of drive torques from power and manual drives with inclined output on driven shaft.
- Steel GKN articulated coupling with corrosion protection, needle bearing and seal ring.
- The maximum deflection angle of 34° / 50° must not be exceeded while in operation.

Note:

- When using two universal joints in series, assure proper adjustment of universal joint (deflection) error through mirror-symmetry during installation!

GKN 01

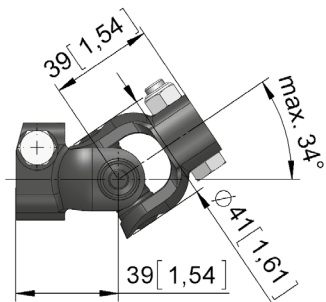

GKN 04

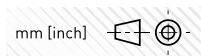
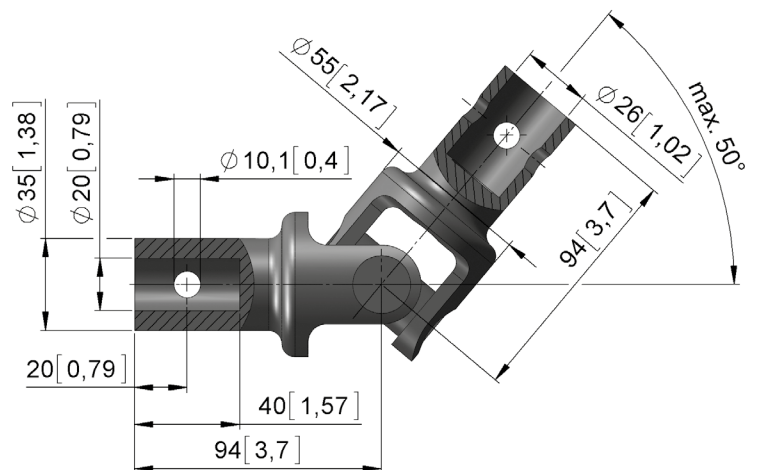

Version	Type no.	T max [Nm]	m [kg]
GKN 01.2121	20810.0100	70	0,3
GKN 04.2620	20820.2620	120	1,1