

HWA 53 // Manual drives 40–160 Nm

HWA 53.05



- Robust manual drives with shaft outputs on both sides. We 06 available in four different versions.
- Cast housing, milled, self-locking worm gear unit.
- Gearbox units made of hardened steel.

→ HWA 53.05 with hand crank HKU 01/HKU 02 (see Chapter [10](#)).

HWA 53.08



- HWA 53.08 with sprocket wheel, chain guide and round steel hand chain HKU 96 (DIN 766, $\varnothing 5 \times 18.5 \times 17$ mm), galvanised, in various lengths (to be ordered separately).

- HWA 53.10 for long cranks (tube on structure side) with mounting turned through 90°, for optimum adjustment to suit actuation height. **Note:** Torque reduced!
- Delivery incl. joint, grip sleeve and crank.

HWA 53.20



- HWA 53.20 with round drive shaft for extended crank. Tube for extension on building structure.

HWA 53.10



Option:

- Hand crank with folding handle (see Chapter [10](#)).



Version	Type no.	T [Nm]	i	F _H [N]	a [mm]	m [kg]
HWA 53.05						
HWA 53.0504	52105.0401.06	40	9 : 1	90	40,0	4,6
HWA 53.0508	52105.0801.06	80	14 : 1	150	40,0	4,6
HWA 53.0512	52105.1201.06	120	18 : 1	130	46,5	4,8
HWA 53.0516	52105.1601.06	160	22 : 1	150	46,5	4,8

HWA 53.08						
HWA 53.0804	52108.0401.06	40	9 : 1	225	40,0	4,7
HWA 53.0808	52108.0801.06	80	14 : 1	360	40,0	4,7
HWA 53.0812	52108.1201.06	120	18 : 1	315	46,5	4,9
HWA 53.0816	52108.1601.06	160	22 : 1	455	46,5	4,9

Version	Type no.	HK [ca. m]	LK [m]	Info	m [kg]
HKU 96.0502	82396.6605.02	1,50	2,00	Round steel hand chain	1,0
HKU 96.0504	82396.6605.04	2,50	4,00	Round steel hand chain	2,0
HKU 96.0506	82396.6605.06	3,50	6,00	Round steel hand chain	3,0
HKU 96.0507	82396.6605.07	4,20	7,50	Round steel hand chain	3,8
HKU 96.0509	82396.6605.09	5,00	9,00	Round steel hand chain	4,5

HWA 53.05

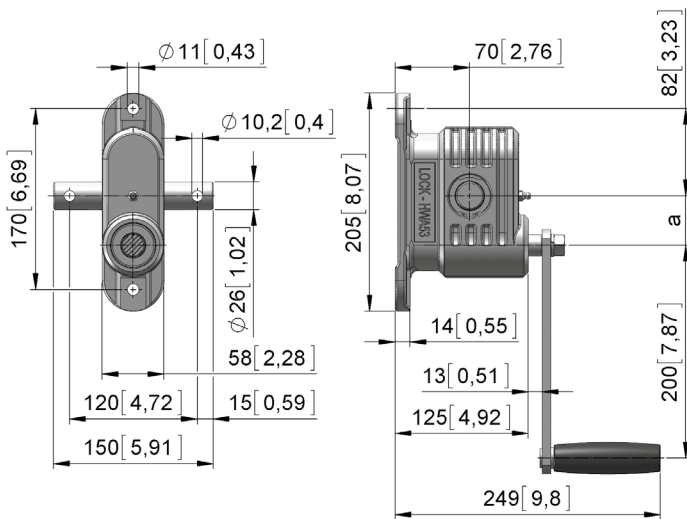

HWA 53.08

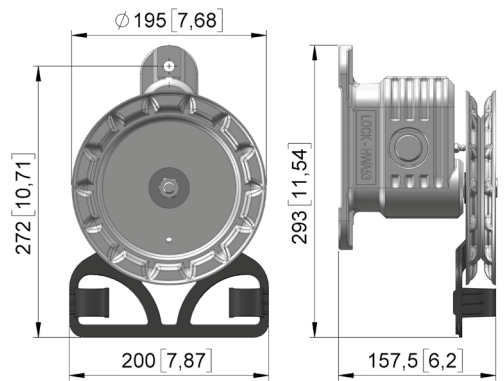

→ Order chain separately!

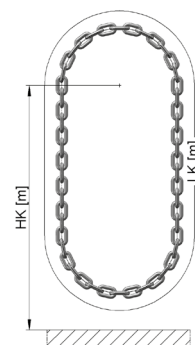

HKU 96.05
Round steel hand chain

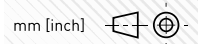



Version	Type no.	T [Nm]	i	F _H [N]	a [mm]	m [kg]
HWA 53.10						
HWA 53.1012	52110.1201.06	90	18 : 1	130	46,5	4,8
HWA 53.1016	52110.1601.06	120	22 : 1	150	46,5	4,8
HWA 53.20						
HWA 53.2004	52120.0401.06	40	9 : 1	-	40,0	4,1
HWA 53.2008	52120.0801.06	80	14 : 1	-	40,0	4,1
HWA 53.2012	52120.1201.06	120	18 : 1	-	46,5	4,3
HWA 53.2016	52120.1601.06	160	22 : 1	-	46,5	4,3

HWA 53.10

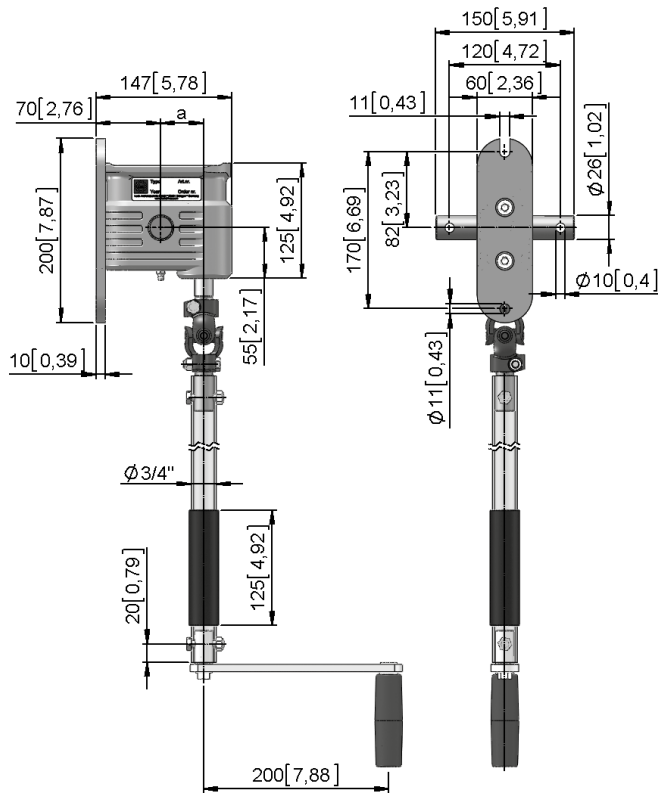

HWA 53.20

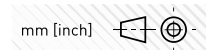
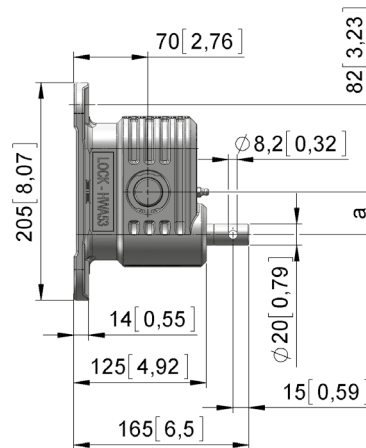

Accessories



HKU 96.0116



MPL 75.2246



HKU 01.2020

→ Table part 3 of 3

Version	Type no.	KL [m]	Info	m [kg]
HKU 96.0116	82396.0101.16	-	Manual sprocket wheel	0,8
MPL 75.2246	82575.2246.01	-	Mounting plate	1,2
HKU 01.2020	82301.2020.0001	200	Crank	0,6

HKU 96.0116
Manual sprocket wheel

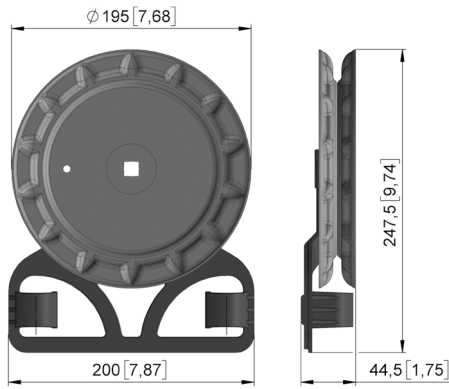

MPL 75.2246
Mounting plate

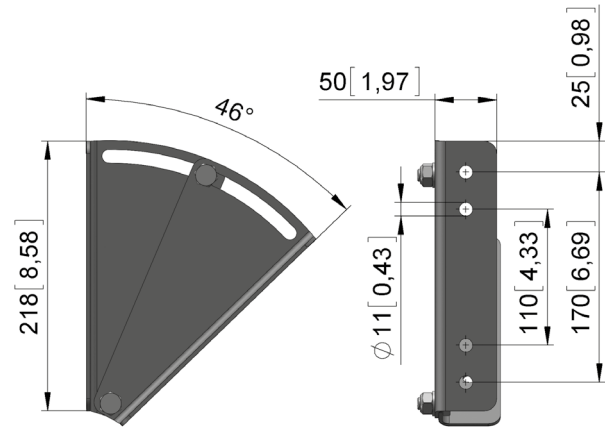

HKU 01.2020
Crank

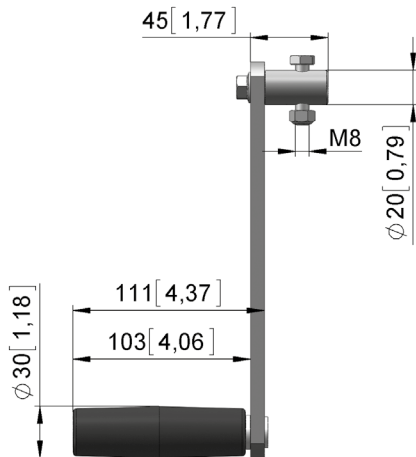

mm [inch]