

HZW 55 // Manual rack winch 12000 N



- Manual rack winches for raising, lowering, adjusting and securing components, devices, machines and ventilation systems.
- Compact design ideal for small installation spaces.
- Smooth action, self-locking worm gear drives.
- Cast housing, milled worm gear unit, gearbox components made of steel, partially hardened, robust precision design.
- Loadable in tension and compression.
- Standard stroke lengths of 600–1400 mm. Additional stroke possible in increments of 200 mm. From stroke length of 1500 mm, note reduced compression force.

Versions:

- HZW 55.1210: Like standard, but lateral shaft outputs to drive version HZW 55.1211 (without self-locking action, stroke = 75mm/n) synchronously. Total load 12000 N, connection with 1" tube DIN EN 10255.
- HZW 55.1220: like standard, but shaft with rear output to drive version HZW 55.1222 synchronously. If more than two racks are needed in one line, the HZW 55.1221 can be employed. Instead of a crank, it has two round shaft ends. Total load 12000 N, connection with 3/4" tube DIN EN 10255.
- If several racks are needed to distribute the loads across a surface area, there are versions HZW 55.1212 and HZW 55.1213, see illustration showing this combination.

Options:

- Folding handle, galvanised version (see Chapter 10). [Not for the ATEX version.]
- Rack guard.
- ATEX Version:  II 3 G Ex h IIB T3 Gc (gas)
II 3 D Ex h IIIB T200°C Dc (dust)



— HKU 01.2020
Not for the ATEX
version.

— HKU 01.2010
Not for the ATEX
version.

HZW 55 combinations

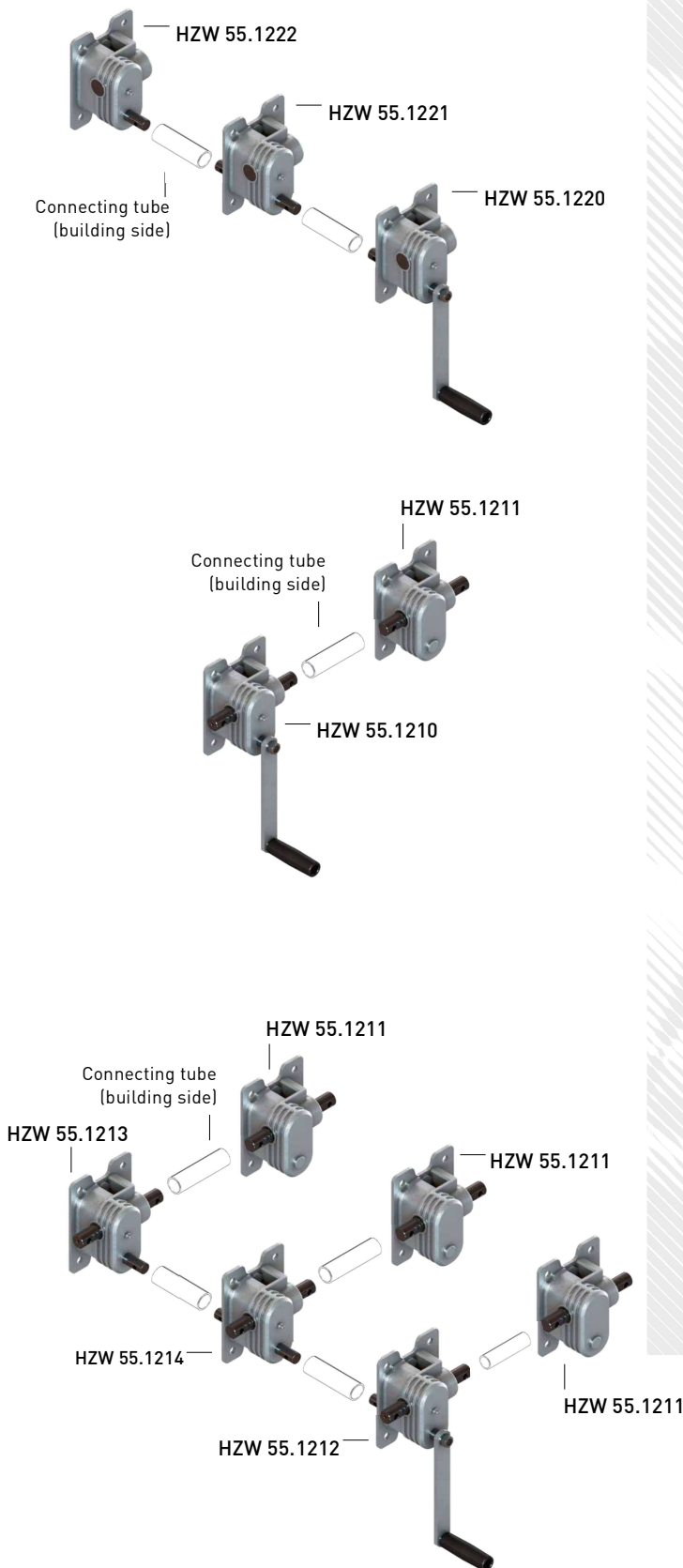

→ On systems with several racks in line to the crank axis

→ Self-locking action in every gear unit

→ 18 kg crank force with a total load of 12000 N

→ Connection to 1" tube on building side

+

→ On systems with several racks in line at 90° to the crank axis

→ Self-locking action only gear unit with crank

→ 18 kg crank force at a maximum total load of 12000 N

→ Connection to 1" tube on building side

=

→ On systems with several racks across a surface area

→ Self-locking action in all gear units in the crank axis

→ 18 kg crank force with a total load of 12000 N

→ Connection to 1" tube and 1" tube

→ ATEX version only available as single drive.

with crank

HZW 55.1201

HZW 55.1220

→ Attention: Additional potential equalization required for ATEX version.

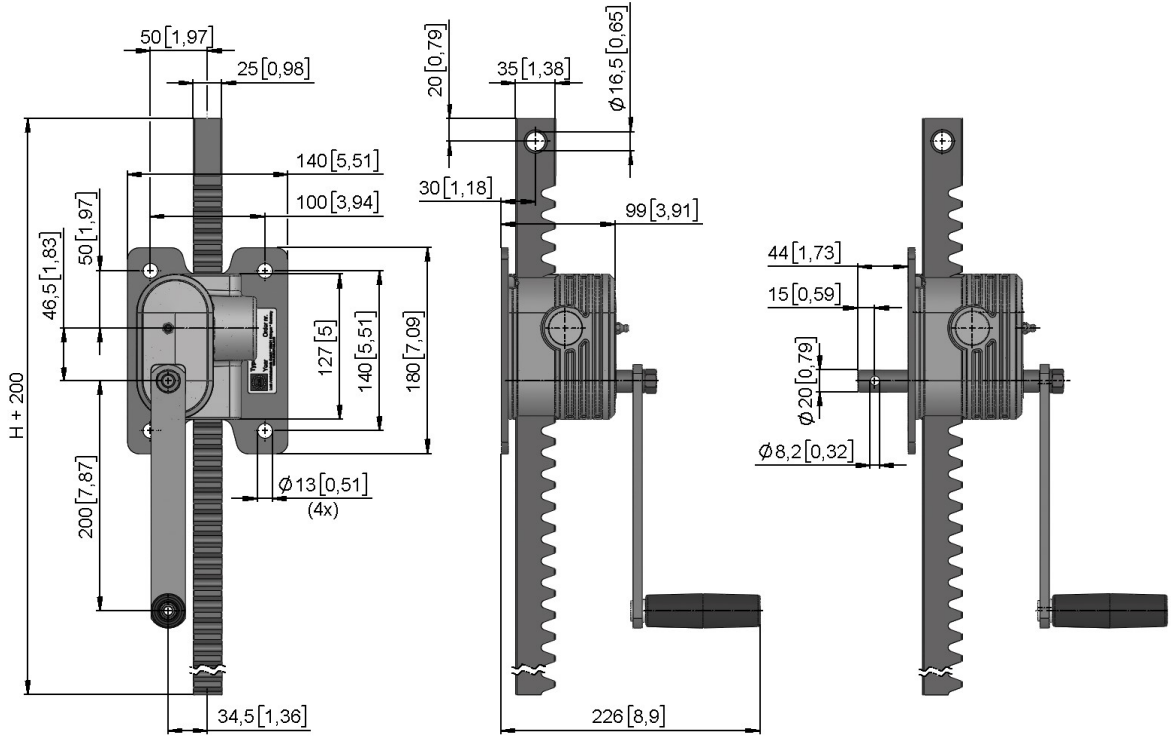

with crank and right through shaft

HZW 55.1210

HZW 55.1212

→ Attention: Not available as ATEX version.

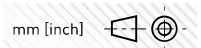
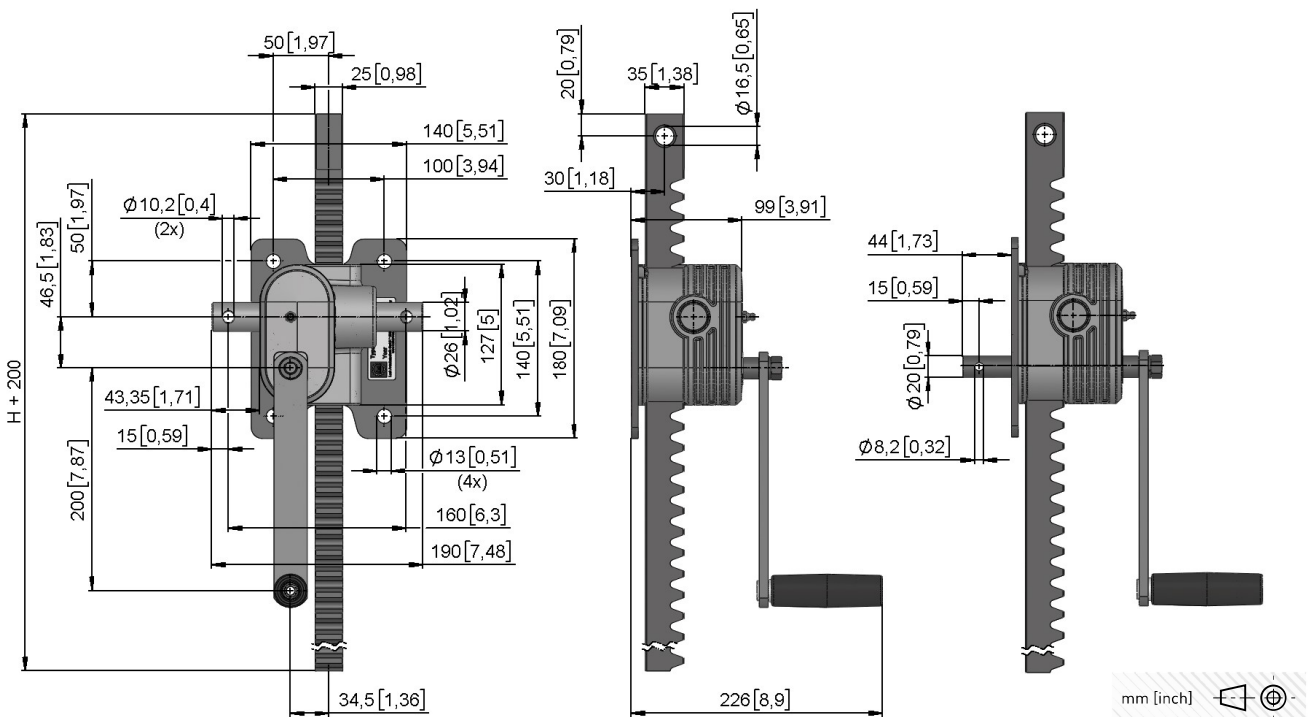

HZW 55 // Gear units

12000 N



Version	Type no.	F [N]	H _k [mm/n]	F _H [N]	m [kg]
HZW 55.1201	51355.1201.00	12000	3,6	180	4,8
HZW 55.1210	51355.1210.00	12000	3,6	180	5,1
HZW 55.1211	51355.1211.00	12000	75,4	-	3,0
HZW 55.1212	51355.1212.00	12000	3,6	180	4,9
HZW 55.1213	51355.1213.00	12000	3,6	180	4,2
HZW 55.1214	51355.1214.00	12000	3,6	180	4,4
HZW 55.1220	51355.1220.00	12000	3,6	180	5,0
HZW 55.1221	51355.1221.00	12000	3,6	180	4,5
HZW 55.1222	51355.1222.00	12000	3,6	180	4,3
HZW 55.1201 EX	51355.1201.0080	10000	3,6	180	4,8

→ Note: Rack is supplied loose!

HZZ 55 // Racks

12000 N



Option:
Rack guard



Version	Type no.	F [N]	H [mm]	L [mm]	m [kg]
HZZ 55.1206	51355.1297.06	12000	600	800	4,1
HZZ 55.1208	51355.1297.08	12000	800	1000	5,2
HZZ 55.1210	51355.1297.10	12000	1000	1200	6,5
HZZ 55.1212	51355.1297.12	12000	1200	1400	7,6
HZZ 55.1214	51355.1297.14	12000	1400	1600	8,8
Option					
HZZ 55.1298	51355.1297.9801	-	-	-	0,1

Accessories

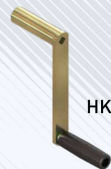

HKU 01.2010



HKU 01.2020

Version	Type no.	KL [m]	Info	m [kg]
HKU 01.2010	82301.2010.0001	200	Crank	0,8
HKU 01.2020	82301.2020.0001	200	Crank	0,6