

MPL 42, MPL 46 // Mounting plates

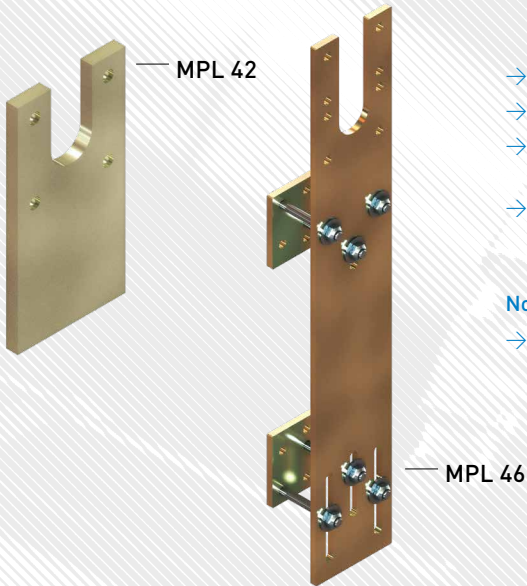

- Mounting plate for transverse mounting of EWA units.
- MPL 42 for welding or bolting to beams or supports.
- MPL 46 for clamping to rail mountings, e.g. in Venlo structures. Variable for use with various rail mounting dimensions.
- Due to the clamping function, no additional drilling is required for the MPL 46.

Note:

- The holes needed for bolting in mounting plate MPL 42 must be drilled additionally.

MPL 42
for EWA 10 – EWA 14

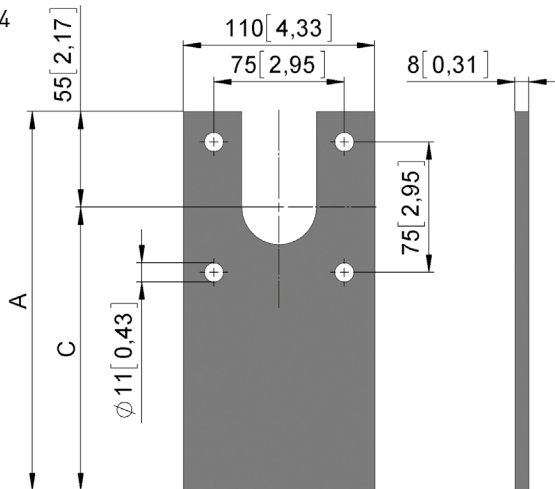

MPL 46
for EWA 10 – EWA 16

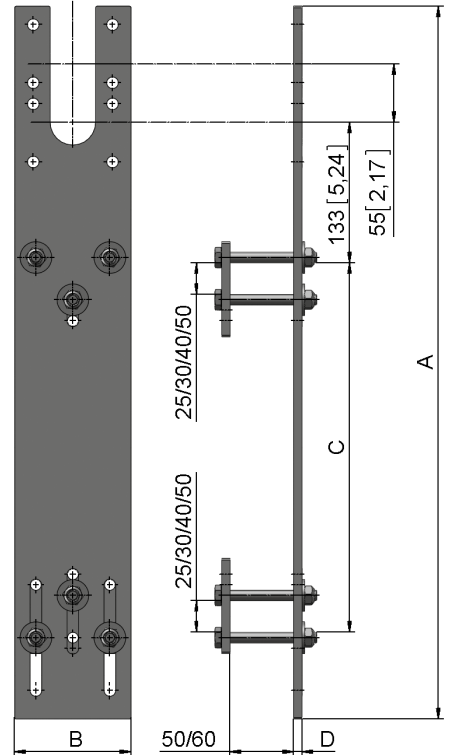

MPL 42
for EWA 16

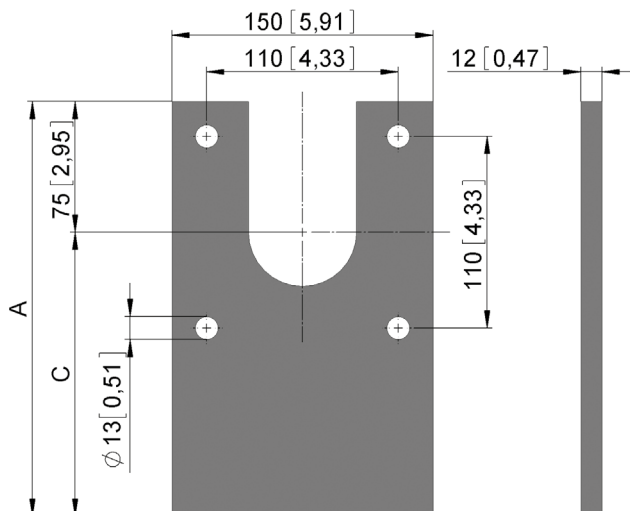

mm [inch]

MPL 42



Version	Type no.	A [mm]	C [mm]	m [kg]
EWA 10/12/14				
MPL 42.1121	82442.1101.2104	218	163	1,2
MPL 42.1158	82442.1101.5804	584	529	3,9
MPL 42.1165	82442.1101.6504	645	590	5,1
EWA 16				
MPL 42.1523	82442.1502.2304	238	163	2,9
MPL 42.1578	82442.1502.7804	785	710	12,5

MPL 46



Version	Type no.	A [mm]	B [mm]	C [mm]	D [mm]	m [kg]
EWA 10/12/14						
MPL 46.1167	82546.1102.0001	675	110	350-399	8	6,0
MPL 46.1172	82546.1102.0002	725	110	400-449	8	6,2
MPL 46.1177	82546.1102.0003	775	110	450-499	8	6,5
MPL 46.1182	82546.1102.0004	825	110	500-549	8	6,7
MPL 46.1187	82546.1102.0005	875	110	550-599	8	7,0
MPL 46.1192	82546.1102.0006	925	110	600-649	8	7,2
MPL 46.1197	82546.1102.0007	975	110	650-699	8	7,4
MPL 46.1102	82546.1102.0008	1025	110	700-749	8	7,7
EWA 16						
MPL 46.1572	82546.1502.0001	720	150	350-399	12	10,2
MPL 46.1577	82546.1502.0002	770	150	400-449	12	10,6
MPL 46.1582	82546.1502.0003	820	150	450-499	12	11,7
MPL 46.1587	82546.1502.0004	870	150	500-549	12	12,4
MPL 46.1592	82546.1502.0005	920	150	550-599	12	13,1
MPL 46.1597	82546.1502.0006	970	150	600-649	12	13,8
MPL 46.1502	82546.1502.0007	1020	150	650-699	12	14,5
MPL 46.1507	82546.1502.0008	1070	150	700-749	12	15,2