

STR 22 // Cable drum units

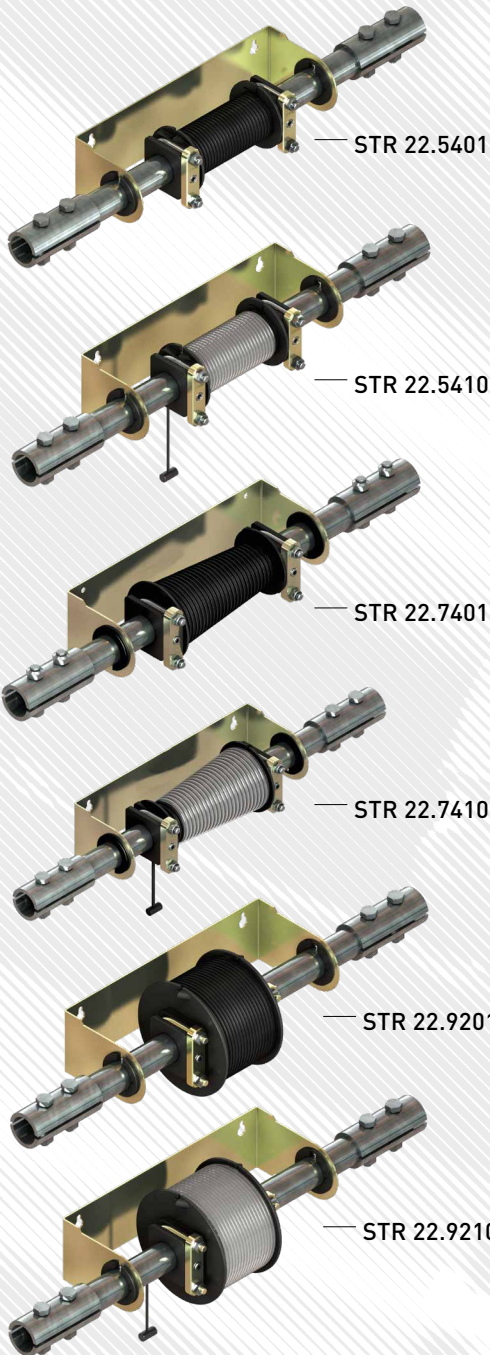

STR 22.54 // STR 22.92:

- Plastic cable drums with mounting console for the VariVent® systems or lifting windows.
- Drums with patented clamping fixture, no further drilling required!
- With 4 half-shell connectors, incl. screws and lock nuts.
- For simple and quick assembly without sawing and drilling, with pre-drilled 1" tubes.
- For cable diameters of up to 4 mm.
- Version xx10 always with pre-mounted wire cable. Process for controlled winding of cable during assembly has been submitted for utility patent application.

STR 22.74:

- For single-rolled TFS systems with a ventilation height of up to 3.5 m.
- Only a small winding tube offset ($\pm 5 - 10$ cm).
- Only a small base is needed, which delivers a bigger cross section for ventilation with eaves at the same height.
- Flexible range of applications: Depending on which area of the tapered drum is used, the winding offset for different thicknesses of sheeting can be optimised.
- Easy to install with tried and tested gripper clamps.

Note:

- Indication H without two safety windings.

Version	Type no.	DR [mm]	DIN 3069 D ϕ [mm]	LL [mm]	H [m]	Info	m [kg]
STR 22.5401	81422.5401.10	54	3-4	70	4,1	-	3,2
STR 22.5410	81422.5410.40	54	3	70	4,1	With pre-mounted wire cable	3,7
STR 22.7401	81422.7401.15	49-74	3-4	70	3,8	-	3,7
STR 22.7410	81422.7410.40	49-74	3	70	3,8	With pre-mounted wire cable	4,4
STR 22.9201	81422.9201.09	120	3-4	90	5,8	-	3,4
STR 22.9210	81422.9210.60	120	3	90	5,8	With pre-mounted wire cable	4,0

STR 22.54

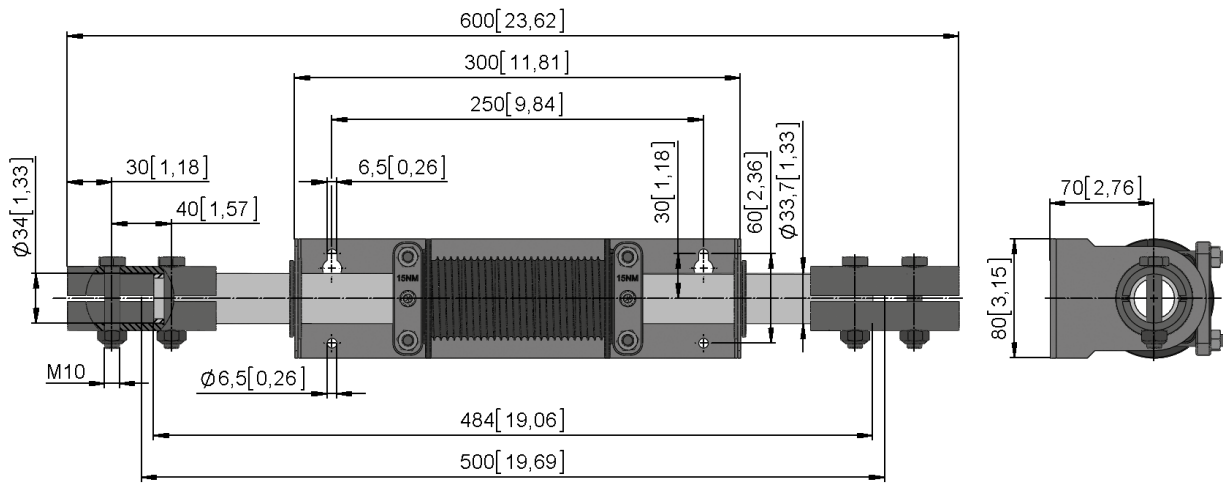

STR 22.74

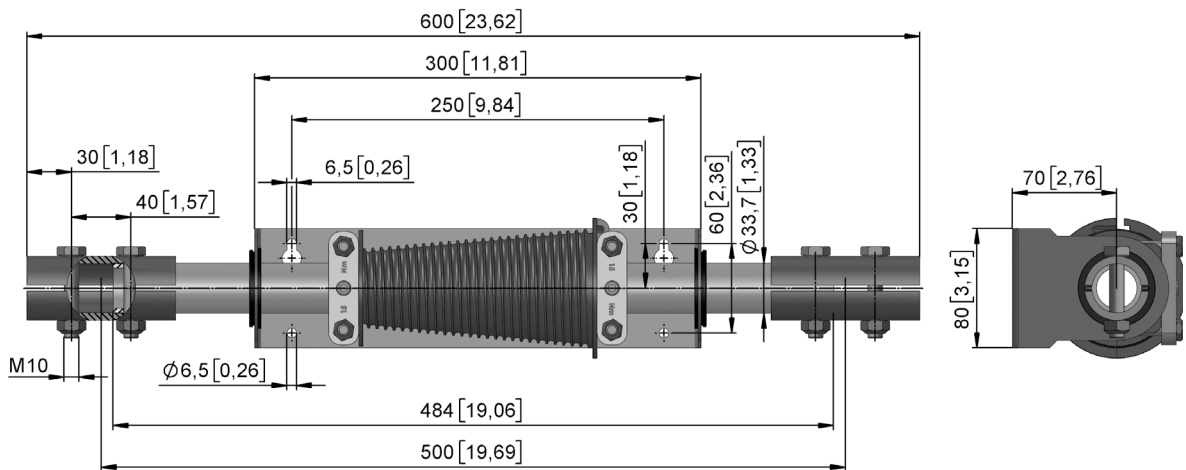

STR 22.92

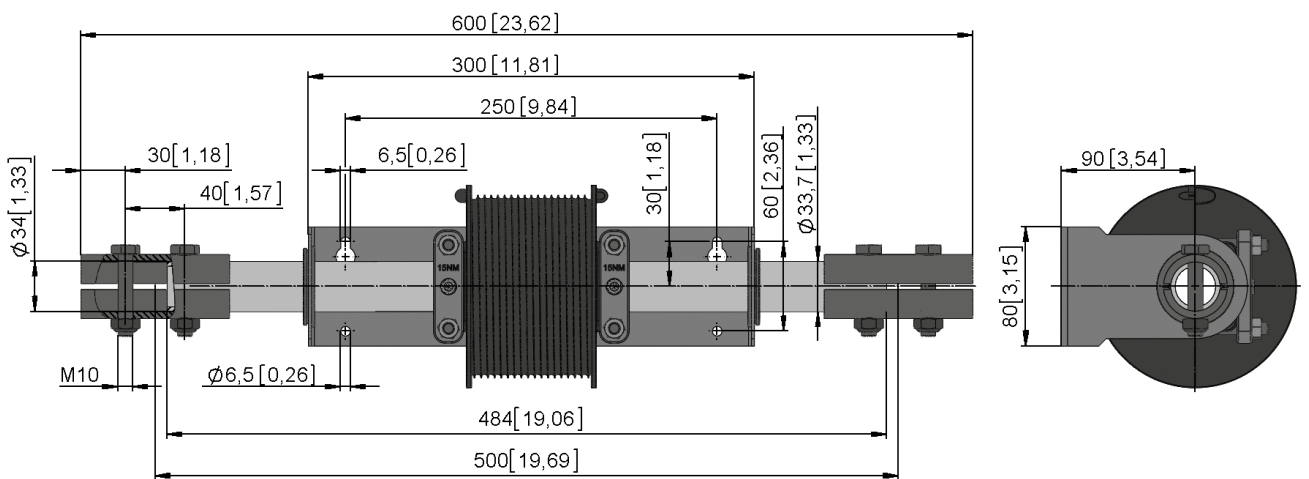

mm [inch]