

STR 41, STR 43, STR 45 // Cable drum units

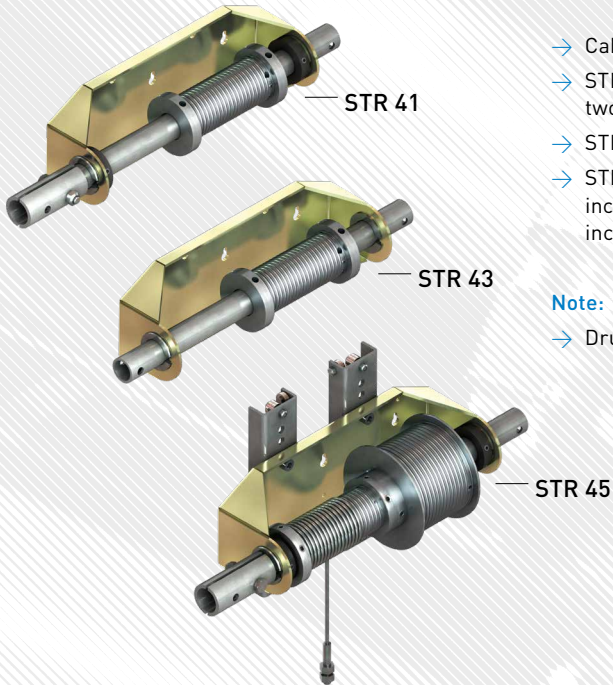

- Cable drum consoles for the VariVent® TF Diabolo system.
- STR 41 (70 mm) cable drum console for simple winding action with two half-shell connectors, incl. screws and lock nuts.
- STR 43 (90 mm) upper cable drum console for double winding.
- STR 45 (90 mm) lower cable drum console for double winding incl. roller carriage and wire cable with two half-shell connectors, incl. screws and lock nuts.

Note:

- Drum 54 mm for 1"-tube is available separately, loads up to 5000 N.

STR 41.5502

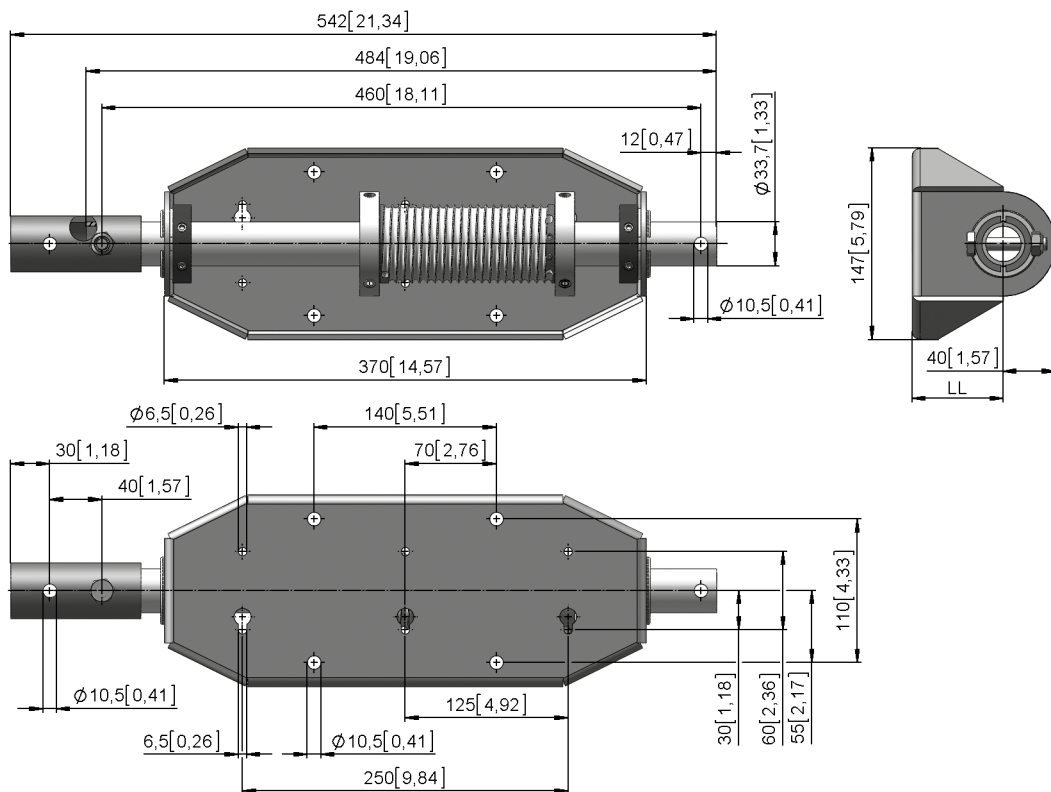

mm [inch]

STR 41, STR 43, STR 45



Version	Type no.	DIN 3060 ø [mm]	LL [mm]	Rolling method	Info	m [kg]
STR 41.5501	81441.5501.10	5	70	grooved/left	-	4,5
STR 41.5502	81441.5502.10	5	70	grooved/left	Incl. clamping rings, GKT connectors	5,0
STR 43.5501	81443.5501.10	5	90	grooved/left	-	4,7
STR 45.9501	81445.9501.10	5	90	grooved/left	Incl. clamping rings, GKT connectors, roller carriage, DST	10,8

STR 43.5501 // STR 41.5501

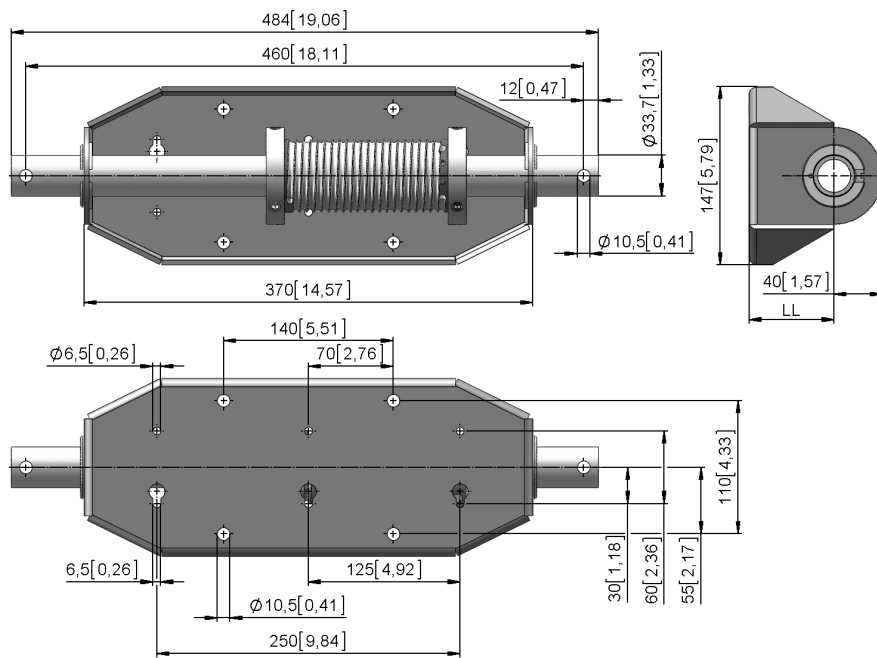

mm [inch]

STR 45.9501

