

# WRA 50, WRA 63 // Tube motor adapter



- Tube motor adapter as connection from RMA to winding shaft and/or drive shaft.
- WRA 50 for connection of RMA 20.05 with the winding shaft.
- WRA 63 for connection of RMA 20.12 with the winding shaft.
- Delivery incl. screws and lock nuts.

**Note:**

- The adapters are riveted to the side of the tube motor.
- WRA 50.0175 is riveted to tube motor and winding shaft.

## WRA 50.01

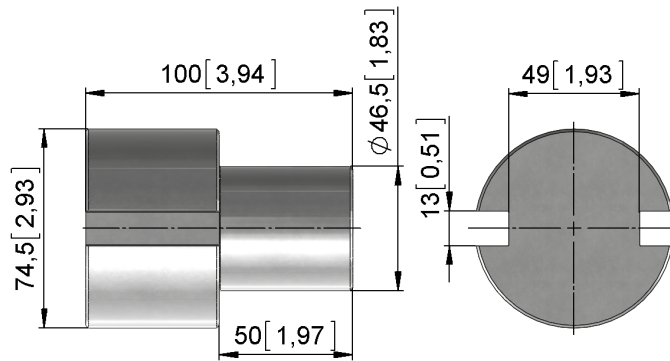

## WRA 50.02 // WRA 63.02

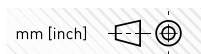
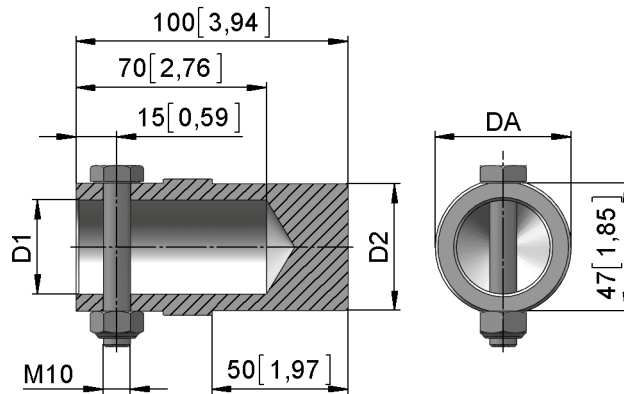

Version	Type no.	D1 [mm]	D2 [mm]	DA [mm]	Info	m [kg]
WRA 50.0175	20998.5001.75	-	-	-	RMA 20.05 // Tube $\varnothing$ 78 x 1,5 mm	0,8
WRA 50.0222	20998.5002.22	22,5	46,5	50	RMA 20.05 // Tube $\varnothing$ 22 x 2 mm	0,5
WRA 50.0232	20998.5002.32	32,5	46,5	50	RMA 20.05 // Tube $\varnothing$ 32 x 1,5 mm	0,4
WRA 50.0234	20998.5002.34	34,5	46,5	50	RMA 20.05 // Tube 1"	0,4
WRA 63.0222	20998.6302.22	22,5	59,5	63	RMA 20.12 // Tube $\varnothing$ 22 x 2 mm	0,7
WRA 63.0232	20998.6302.32	32,5	59,5	63	RMA 20.12 // Tube $\varnothing$ 32 x 1,5 mm	0,7
WRA 63.0234	20998.6302.34	34,5	59,5	63	RMA 20.12 // Tube 1"	0,7