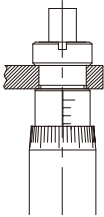
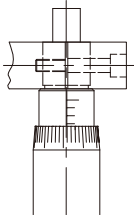

### Purpose

The micrometer type is particularly designed for high accuracy positioning devices, such as optical instruments, precisely fine tuning stages, various machine tools, gauging instruments, precisely positioning devices, fixed amount transmissions, etc.

### Installation

The heads of the micrometers are classified by their forms as the type of lock screw and set screw.

Fixing form	Lock Screw		Set Screw	
	Installation Diagram			
Shaft Dia.	Ø6	Ø9.525 Ø9.5	Ø6	Ø9.525 Ø9.5
Mounting Hole Tolerance	G7(+0.004~-+0.016)	G7(+0.005~-+0.020)	G7(+0.004~-+0.016)	G7(+0.005~-+0.020)
Notice	The right angle opposite to mounting hole A must be within 0.16/6.5, degrees, or the fixing may be affected		Please notice burrs occurred from inner wall of mounting holes.	
Axial Static Load	8.63~9.8kN(880~1000kgf)		0.69~0.98kN(70~100kgf)	
Remark	Simply and firmly locked		need of locking and tacking process	

★ Loading data is exclusive of maintaining accuracy

### Micrometer selection

The considerations of selecting a micrometer might be including gauging range, the shape of gauging face, shaft, and the size of reading axis. Selections should be based on purposes.

### Gauging plane selection

The shaft is designed with the most suitable dimension for the body using an allowable tolerance h6.

Once the instrument be used for gauging purposes, it is generally suggested to use the plate type; for transferring purposes, using the sphere type could minimize the errors.