

# BALL SPLINE

## ROTARY BALL SPLINE

## STROKE BALL SPLINE

## BALL SCREW SPLINE

### BALL SPLINE

STRUCTURE AND ADVANTAGES	B-2
TYPES	B-3
ACCURACY	B-5
PRELOAD AND CLEARANCE IN ROTATIONAL DIRECTION	B-6
STRENGTH OF SPLINE SHAFT	B-7
LOAD RATING	B-8
CALCULATION OF DEFLECTION AND DEFLECTION ANGLE OF SPLINE SHAFT	B-9
ALLOWABLE ROTATIONAL SPEED OF SPLINE SHAFT	B-10
RATED LIFE CALCULATION	B-11
MOUNTING	B-11
OPERATING CONDITIONS	B-12
LUBRICATION	B-12
HOLLOW SPLINE SHAFT	B-12
SPECIAL REQUIREMENTS	B-13
NUT ORIENTATION	B-13
USE AND HANDLING PRECAUTIONS	B-13
MOUNTING	B-14
DIMENSION TABLE	B-18~
STANDARD AND MAXIMUM LENGTH	B-30
COMMERCIAL BALL SPLINE	B-31

### ROTARY BALL SPLINE

STRUCTURE AND ADVANTAGES	B-32
ACCURACY OF SPR TYPE	B-33
ACCURACY OF SPB TYPE	B-34
PRELOAD AND CLEARANCE IN ROTATIONAL DIRECTION	B-35
HOLLOW SPLINE SHAFT	B-35
SPECIAL REQUIREMENTS	B-35
MOUNTING	B-36
LUBRICATION	B-37
NUT ORIENTATION	B-38
OPERATING CONDITIONS	B-38
APPLICATION EXAMPLES	B-39
DIMENSION TABLE	B-40~

### STROKE BALL SPLINE

STRUCTURE AND ADVANTAGES	B-46
ACCURACY	B-47
PRELOAD AND CLEARANCE IN ROTATIONAL DIRECTION	B-48
COMPARISON OF DYNAMIC FRICTIONAL RESISTANCE	B-48
NUT ORIENTATION	B-49
USE AND HANDLING PRECAUTIONS	B-49
DIMENSION TABLE	B-50~

### BALL SCREW SPLINE

STRUCTURE AND ADVANTAGES	B-52
PRELOAD	B-52
USE AND HANDLING PRECAUTIONS	B-52
ACCURACY	B-53
SPBR TYPE MOTION PATTERN	B-54
SPBF TYPE MOTION PATTERN	B-55
STANDARD AND MAXIMUM LENGTH	B-55
DIMENSION TABLE	B-56~

# BALL SPLINE

The NB ball spline is a linear motion mechanism utilizing the rolling motion of ball elements that can sustain loads and transfer torque simultaneously. It can be used in a wide variety of applications including robotics and transport type equipment.

## STRUCTURE AND ADVANTAGES

The NB ball spline consists of a spline shaft with raceway grooves and a spline nut. The spline nut consists of an outer cylinder (main body), retainer, side rings, and ball elements that is designed and manufactured to achieve a reliably smooth motion.

### High Load Capacity and Long Travel Life

The raceway grooves are machined to a radius close to that of the ball elements. The large ball contact area results in high load capacity and long travel life.

### Wide Variety of Configurations

Spline shaft sizes with diameters from 4mm to 100mm are available. Several types of Spline nut are available: cylindrical types (SSP/SSPM), and flange types (SSPF/SSPT). Material option of Stainless steel (SUS440C or equivalent) is also available. They can be specified to suit various applications.

### High Accuracy Torque Transmission

Due to the effective contact angle between the raceway grooves and the balls, the NB ball spline can transfer large torque. By adjusting preload it is possible to obtain a higher rigidity and a higher positioning accuracy.

### Ease of Additional Custom Machining

Since a round shaft with raceway grooves is used, NB ball spline shafts can be easily machined to customized specifications.

### High-Speed Motion and High-Speed Rotation

The outer cylinder is compact and well balanced, resulting in good performance at high speed.

### LIGHT WEIGHT and COMPACTNESS

The NB ball spline SSP-AM type has a smaller spline-nut diameter compared to the conventional SSP type nut on the same shaft diameter. The SSP-AM type is best suited for the chip-mounter head device and the multi-axial applications. Anti-corrosion type is also available.

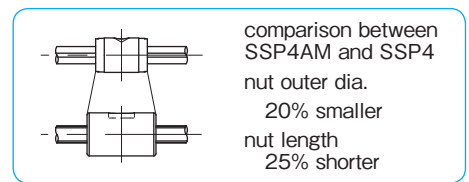
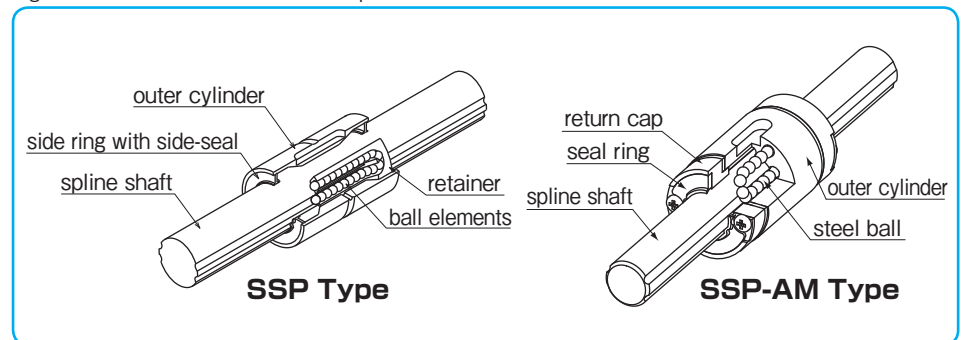

Figure B-1 Basic Structure of NB Ball Spline



## TYPES

### TYPES OF SPLINE NUT

A wide variety of spline nut designs are available and all spline nuts come with side-seals as a standard feature.

Table B-1 Types of Spline Nut

type of nut		shape and advantage		page
cylindrical type	SSP SSPS		<ul style="list-style-type: none"> <li>cylindrical spline nut with key groove</li> <li>with special key</li> <li>nominal diameter: SSP4-100 : SSPS4-25</li> </ul>	P.B-18
	SSP-AM SSPS-AM		<ul style="list-style-type: none"> <li>light and compact nut</li> <li>countersink for fixing (SSP4AM)</li> <li>with special key</li> <li>nominal diameter: 4-10</li> </ul>	P.B-20
	SSPM		<ul style="list-style-type: none"> <li>cylindrical spline nut without key groove</li> <li>with two lock plates for fixing</li> <li>nominal diameter: 6-10</li> </ul>	P.B-22
flange type	SSPF SSPFS		<ul style="list-style-type: none"> <li>spline nut with flange</li> <li>nominal diameter: SSPF6-60 : SSPFS6-25</li> </ul>	P.B-24
	SSPT		<ul style="list-style-type: none"> <li>spline nut with a two side cut flange</li> <li>nominal diameter: 6-10</li> </ul>	P.B-26
	SSPT-AM SSPK-AM SSPTS-AM SSPKS-AM		<ul style="list-style-type: none"> <li>light and compact nut with flange</li> <li>nominal diameter: 4-10</li> </ul>	P.B-28

**TYPES OF SPLINE SHAFT**

Depending on the application requirements, either a ground spline shaft or a non-ground (commercial grade) spline shaft is available.

Table B-2

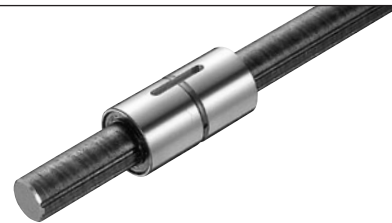
type of spline shaft	shape and advantage
ground spline shaft	 <ul style="list-style-type: none"> <li>• precision ground and precision machined surface finish</li> <li>• high precision</li> <li>• possible to machine ends of spline shaft and surface treatment</li> <li>• nominal diameter: 4-100</li> </ul>
commercial shaft (non-ground)	 <ul style="list-style-type: none"> <li>• for general industrial use</li> <li>• cost effective</li> <li>• possible to machine ends of spline shaft and surface treatment</li> <li>• nominal diameter: 20-50</li> <li>• maximum length: 5000mm (refer to page B-31)</li> </ul>

**ACCURACY**

The NB ball spline is measured for accuracy at the points shown in Figure B-2 and categorized as either high-grade (blank) or precision-grade (P). Contact NB for accuracy information on the commercial type ball spline.

Figure B-2 Accuracy Measurement Points

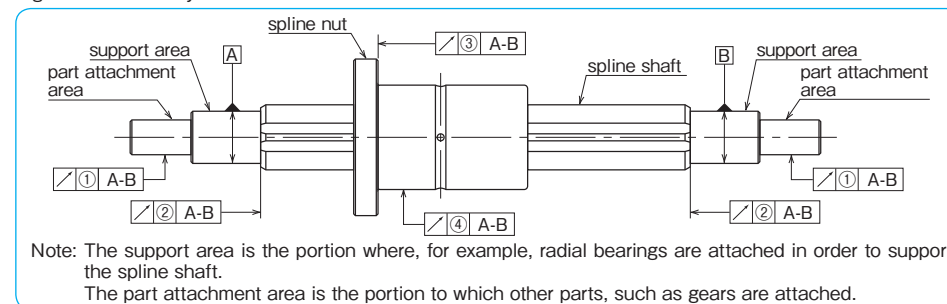

**Tolerance of Spline Shaft Groove Torsion (Max.)**

The groove torsion is indicated per 100mm, arbitrarily set as the effective length of the spline shaft section.

Table B-3  
Tolerance of Spline Shaft Groove Torsion (Max.)

type of shaft	ground shaft	
	high	precision (P)
accuracy grade		
tolerance	13μm/100mm	6μm/100mm

Table B-4 Tolerance Relative to Spline Support Area (Max.)

unit : μm

part number	radial runout of part attachment area ①		radial runout of the end of the spline shaft section ② (when grinding is requested on the drawing)		radial runout of the flange ③	
	high-grade	precision-grade	high-grade	precision-grade	high-grade	precision-grade
SSP 4·4AM	14	8	9	6	—	—
SSP 5AM					11	8
SSP 6·6AM						
SSP 8·8AM						
SSP 10·10AM	17	10	11	8	13	9
SSP 13A	19	12				
SSP 16A						
SSP 20A						
SSP 25A	22	13	13	9	16	11
SSP 30A						
SSP 40A						
SSP 50A						
SSP 60A	29	17	19	13	22	15
SSP 80A						
SSP 80AL						
SSP100A	34	20	22	15	—	—
SSP100AL						
SSP 20	19	12	11	8	13	9
SSP 25	22	13	13	9	16	11
SSP 30						
SSP 40						
SSP 50	25	15	16	11	19	13
SSP 60						

Table B-5 ④ Radial Runout of Outer Surface of Spline Nut Relative to Spline Shaft Support Area (Max.) unit:  $\mu\text{m}$

total length of spline shaft (mm)	greater than	or less	size																	
			SSP4 SSP4AM		SSP5AM SSP6 SSP6AM		SSP8 SSP8AM		SSP10 SSP10AM		SSP13A SSP16A SSP20A-20		SSP25A-25 SSP30A-30		SSP40A-40 SSP50A-50		SSP60A-60 SSP80A SSP80AL		SSP100A SSP100AL	
			high- grade	precision grade	high- grade	precision grade	high- grade	precision grade	high- grade	precision grade	high- grade	precision grade	high- grade	precision grade	high- grade	precision grade	high- grade	precision grade	high- grade	precision grade
—	200	46	26	46	26	46	26	36	20	34	18	32	18	32	16	30	16	30	16	
200	315	89	—	89	57	89	57	54	32	45	25	39	21	36	19	34	17	32	17	
315	400	—	—	126	—	126	82	68	41	53	31	44	25	39	21	36	19	34	17	
400	500	—	—	—	—	163	—	82	51	62	38	50	29	43	24	38	21	35	19	
500	630	—	—	—	—	—	—	102	65	75	46	57	34	47	27	41	23	37	20	
630	800	—	—	—	—	—	—	—	—	92	58	68	42	54	32	45	26	40	22	
800	1,000	—	—	—	—	—	—	—	—	115	75	83	52	63	38	51	30	43	24	
1,000	1,250	—	—	—	—	—	—	—	—	153	97	102	65	76	47	59	35	48	28	
1,250	1,600	—	—	—	—	—	—	—	—	256*	180*	210	140	175	105	70	43	55	33	
1,600	2,000	—	—	—	—	—	—	—	—	394	314	311	241	224	154	179	109	65	40	

★ SSP13A, 16A maximum length: 1500mm  
 ★★ Please contact NB for shaft lengths exceeding 2000mm.

PRELOAD AND CLEARANCE IN ROTATIONAL DIRECTION

Both the clearance and preload are expressed in terms of clearance in the rotational direction. The preload is categorized into three different levels: standard, light (T1), and medium (T2). A preload cannot be specified with the commercial grade spline shaft.

Table B-6 Preload and Clearance in Rotational Direction unit:  $\mu\text{m}$

part number	standard	light (T1)	medium (T2)
SSP 4·4AM	0~+3	-3~0	-
SSP 5AM			
SSP 6·6AM			
SSP 8·8AM			
SSP 10·10AM			
SSP 13A	-3~+1	-8~-3	-13~-8
SSP 16A			
SSP 20A·20	-4~+2	-12~-4	-20~-12
SSP 25A·25			
SSP 30A·30			
SSP 40A·40	-6~+3	-18~-6	-30~-18
SSP 50A·50			
SSP 60A·60			
SSP 80A			
SSP 80AL			
SSP100A			
SSP100AL	-8~+4	-24~-8	-40~-24

Table B-7 Preload and Operating Condition

preload	preload symbol	operating conditions
standard	blank	minute vibration is applied. a precise motion is required. a torque in a given direction is applied.
light	T1	slight vibration is applied. slight torsional load is applied. cyclic torque is applied.
medium	T2	shock/vibration is applied. over-hang load is applied. torsional load is applied.

※Since the contrary relation of preload and dynamic frictional resistance, dynamic frictional resistance will increase when applying preload.

STRENGTH OF SPLINE SHAFT

The ball spline has larger load ratings compared to ball bush. Also, the ball spline can sustain radial load, moment (bending moment) and torque (twisting moment) at the same time. Thus, it is necessary to consider the strength of ball spline shaft.

Using the following equations, select the size of ball spline.

$$\sigma \geq \frac{M}{Z} \dots\dots\dots (1)$$

$\sigma$ : permissible bending stress of spline shaft (98N/mm<sup>2</sup>)  
 M: bending moment onto spline shaft (N·mm)  
 Z: modulus of section (mm<sup>3</sup>)  
 (refer to Table B-8 on page B-8)

Twisting Moment Only

$$\tau_a \geq \frac{T}{Z_p} \dots\dots\dots (2)$$

$\tau_a$ : permissible twisting stress of spline shaft (49N/mm<sup>2</sup>)  
 T: twisting moment onto spline shaft (N·mm)  
 Z<sub>p</sub>: polar modulus of section (mm<sup>3</sup>)  
 (refer to Table B-8 on page B-8)

Bending Moment and Twisting Moment Combined

Calculate equivalent bending moment (Me) by using equation (3). Then, substitute Me into equation (1) for shaft size selection.

$$M_e = \frac{1}{2} \{ M + \sqrt{M^2 + T^2} \} \dots\dots\dots (3)$$

Me: equivalent bending moment (N·mm)  
 M: bending moment onto spline shaft  
 T: twisting moment onto spline shaft

Rigidity of Spline Shaft

The rigidity of spline shaft is expressed in the torsional angle ( $\theta$ ) caused by twisting moment. For high accuracy smooth motion, it is necessary to keep the torsional angle within 0.25° per 1,000mm.

$$\theta = \frac{T \cdot L}{G \cdot I_p} \cdot \frac{360}{2\pi} \dots\dots\dots (4)$$

$$\text{Rigidity} = 0.25^\circ \geq \frac{1,000}{L} \theta \dots\dots\dots (5)$$

$\theta$ : torsional angle (°)  
 T: twisting moment onto spline shaft (N·mm)  
 L: spline shaft length (mm)  
 G: shearing modulus (SUJ2) 7.9×10<sup>4</sup> (N/mm<sup>2</sup>)  
 (SUS) 7.69×10<sup>4</sup> (N/mm<sup>2</sup>)  
 I<sub>p</sub>: polar moment of inertia of area (mm<sup>4</sup>)  
 (refer to Table B-8 on page B-8)

Figure B-3 Bending Moment

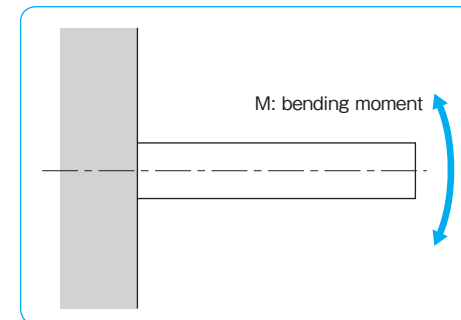

Figure B-4 Twisting Moment

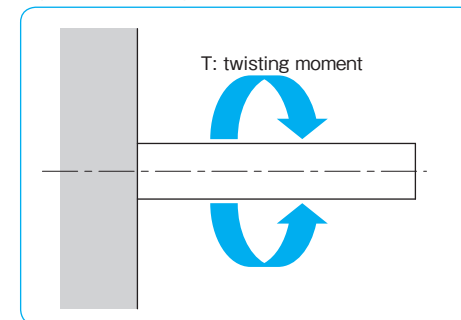

Figure B-5 Deformation of Spline Shaft by Twisting Moment

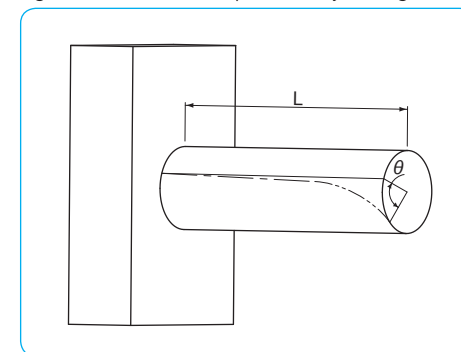

Table B-8 Cross-sectional Characteristics of Spline Shaft

part number	I moment of inertia of area mm <sup>4</sup>	Z modulus of section mm <sup>3</sup>	I <sub>p</sub> polar moment of inertia of area mm <sup>4</sup>	Z <sub>p</sub> polar modulus of section mm <sup>3</sup>	C=1/48EI	
					SUJ2 1/N·mm <sup>2</sup>	SUS440C
SSP 4	1.18×10	5.90	2.41×10	1.20×10	8.57×10 <sup>-9</sup>	8.83×10 <sup>-9</sup>
SSP 6	5.91×10	1.97×10	1.21×10 <sup>2</sup>	4.04×10	1.71×10 <sup>-9</sup>	1.76×10 <sup>-9</sup>
SSP 8	1.90×10 <sup>2</sup>	4.76×10	3.88×10 <sup>2</sup>	9.69×10	5.32×10 <sup>-10</sup>	5.47×10 <sup>-10</sup>
SSP 10	4.61×10 <sup>2</sup>	9.22×10	9.42×10 <sup>2</sup>	1.88×10 <sup>2</sup>	2.19×10 <sup>-10</sup>	2.26×10 <sup>-10</sup>
SSP 13A	1.32×10 <sup>3</sup>	2.03×10 <sup>2</sup>	2.70×10 <sup>3</sup>	4.16×10 <sup>2</sup>	7.66×10 <sup>-11</sup>	7.89×10 <sup>-11</sup>
SSP 16A	2.98×10 <sup>3</sup>	3.73×10 <sup>2</sup>	6.15×10 <sup>3</sup>	7.68×10 <sup>2</sup>	3.39×10 <sup>-11</sup>	3.49×10 <sup>-11</sup>
SSP 20A	7.35×10 <sup>3</sup>	7.35×10 <sup>2</sup>	1.51×10 <sup>4</sup>	1.51×10 <sup>3</sup>	1.38×10 <sup>-11</sup>	1.42×10 <sup>-11</sup>
SSP 25A	1.79×10 <sup>4</sup>	1.43×10 <sup>3</sup>	3.68×10 <sup>4</sup>	2.94×10 <sup>3</sup>	5.65×10 <sup>-12</sup>	5.82×10 <sup>-12</sup>
SSP 30A	3.63×10 <sup>4</sup>	2.42×10 <sup>3</sup>	7.57×10 <sup>4</sup>	5.05×10 <sup>3</sup>	2.79×10 <sup>-12</sup>	—
SSP 40A	1.15×10 <sup>5</sup>	5.73×10 <sup>3</sup>	2.39×10 <sup>5</sup>	1.20×10 <sup>4</sup>	8.83×10 <sup>-13</sup>	—
SSP 50A	2.81×10 <sup>5</sup>	1.12×10 <sup>4</sup>	5.86×10 <sup>5</sup>	2.34×10 <sup>4</sup>	3.60×10 <sup>-13</sup>	—
SSP 60A	5.91×10 <sup>5</sup>	1.97×10 <sup>4</sup>	1.22×10 <sup>6</sup>	4.08×10 <sup>4</sup>	1.71×10 <sup>-13</sup>	—
SSP 80A	1.93×10 <sup>6</sup>	4.83×10 <sup>4</sup>	3.92×10 <sup>6</sup>	9.81×10 <sup>4</sup>	5.24×10 <sup>-14</sup>	—
SSP 80AL						
SSP100A	4.69×10 <sup>6</sup>	9.38×10 <sup>4</sup>	9.55×10 <sup>6</sup>	1.91×10 <sup>5</sup>	2.16×10 <sup>-14</sup>	—
SSP100AL						
SSP 20	5.03×10 <sup>3</sup>	5.53×10 <sup>2</sup>	1.04×10 <sup>4</sup>	1.14×10 <sup>3</sup>	2.01×10 <sup>-11</sup>	2.07×10 <sup>-11</sup>
SSP 25	1.27×10 <sup>4</sup>	1.10×10 <sup>3</sup>	2.63×10 <sup>4</sup>	2.29×10 <sup>3</sup>	7.97×10 <sup>-12</sup>	8.21×10 <sup>-12</sup>
SSP 30	2.74×10 <sup>4</sup>	1.96×10 <sup>3</sup>	5.73×10 <sup>4</sup>	4.10×10 <sup>3</sup>	3.69×10 <sup>-12</sup>	—
SSP 40	8.71×10 <sup>4</sup>	4.66×10 <sup>3</sup>	1.82×10 <sup>5</sup>	9.75×10 <sup>3</sup>	1.16×10 <sup>-12</sup>	—
SSP 50	2.16×10 <sup>5</sup>	9.19×10 <sup>3</sup>	4.53×10 <sup>5</sup>	1.93×10 <sup>4</sup>	4.69×10 <sup>-13</sup>	—
SSP 60	4.50×10 <sup>5</sup>	1.59×10 <sup>4</sup>	9.46×10 <sup>5</sup>	3.35×10 <sup>4</sup>	2.25×10 <sup>-13</sup>	—
SSP 4AM	1.18×10	6.01	2.44×10	1.23×10	8.56×10 <sup>-9</sup>	8.82×10 <sup>-9</sup>
SSP 5AM	2.77×10	1.11×10	5.77×10	2.31×10	3.65×10 <sup>-9</sup>	3.76×10 <sup>-9</sup>
SSP 6AM	5.89×10 <sup>2</sup>	1.96×10	1.22×10 <sup>2</sup>	4.05×10	1.72×10 <sup>-9</sup>	1.77×10 <sup>-9</sup>
SSP 8AM	1.88×10 <sup>2</sup>	4.71×10	3.86×10 <sup>2</sup>	9.66×10	5.37×10 <sup>-10</sup>	5.53×10 <sup>-10</sup>
SSP 10AM	4.53×10 <sup>2</sup>	9.06×10	9.35×10 <sup>2</sup>	1.87×10 <sup>2</sup>	2.23×10 <sup>-10</sup>	2.30×10 <sup>-10</sup>

LOAD RATING

The load rating for SSP-AM type depends on the direction of load.

Table B-9 LOAD RATING

		SSP4AM	SSP5AM~10AM
basic dynamic load rating	vertical	C	C
	horizontal	1.73×C	1.22×C
basic static load rating	vertical	C <sub>0</sub>	C <sub>0</sub>
	horizontal	1.73×C <sub>0</sub>	1.22×C <sub>0</sub>

Figure B-6 Load Direction

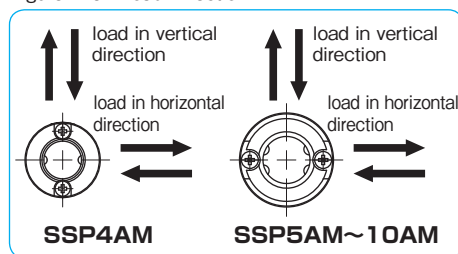

CALCULATION OF DEFLECTION AND DEFLECTION ANGLE OF SPLINE SHAFT

The following formulas are used to obtain the deflection and its angle of the ball spline shaft. Typical conditions are listed in Table B-10.

Table B-10 Formulas for Calculating Deflection and Deflection Angle

support method	specification	formula for deflection	formula for deflection angle
1 support   support		$\delta_{max} = \frac{P\ell^3}{48EI} = P\ell^3C$	$i_1 = 0$ $i_2 = \frac{P\ell^2}{16EI} = 3P\ell^2C$
2 fixed   fixed		$\delta_{max} = \frac{P\ell^3}{192EI} = \frac{1}{4}P\ell^3C$	$i_1 = 0$ $i_2 = 0$
3 support   support		$\delta_{max} = \frac{5p\ell^4}{384EI} = \frac{5}{8}p\ell^4C$	$i_2 = \frac{p\ell^3}{24EI} = 2p\ell^3C$
4 fixed   fixed		$\delta_{max} = \frac{p\ell^4}{384EI} = \frac{1}{8}p\ell^4C$	$i_2 = 0$
5 support   support		$\delta_1 = \frac{Pa^3}{6EI} \left(2 + \frac{3b}{a}\right) = 8Pa^3 \left(2 + \frac{3b}{a}\right)C$ $\delta_{max} = \frac{Pa^3}{24EI} \left(\frac{3\ell^2}{a^2} - 4\right) = 2Pa^3 \left(\frac{3\ell^2}{a^2} - 4\right)C$	$i_1 = \frac{Pab}{2EI} = 24PabC$ $i_2 = \frac{Pa(a+b)}{2EI} = 24Pa(a+b)C$
6 fixed   fixed		$\delta_1 = \frac{Pa^3}{6EI} \left(2 - \frac{3a}{\ell}\right) = 8Pa^3 \left(2 - \frac{3a}{\ell}\right)C$ $\delta_{max} = \frac{Pa^3}{24EI} \left(2 + \frac{3b}{a}\right) = 2Pa^3 \left(2 + \frac{3b}{a}\right)C$	$i_1 = \frac{Pa^2b}{2EI\ell} = \frac{24Pa^2bC}{\ell}$ $i_2 = 0$
7 fixed   free		$\delta_{max} = \frac{P\ell^3}{3EI} = 16P\ell^3C$	$i_1 = \frac{P\ell^2}{2EI} = 24P\ell^2C$ $i_2 = 0$
8 fixed   free		$\delta_{max} = \frac{p\ell^4}{8EI} = 6p\ell^4C$	$i_1 = \frac{p\ell^3}{6EI} = 8p\ell^3C$ $i_2 = 0$
9 support   support		$\delta_{max} = \frac{\sqrt{3}Mo\ell^2}{216EI} = \frac{2\sqrt{3}}{9}Mo\ell^2C$	$i_1 = \frac{Mo\ell}{12EI} = 4Mo\ell C$ $i_2 = \frac{Mo\ell}{24EI} = 2Mo\ell C$
10 fixed   fixed		$\delta_{max} = \frac{Mo\ell^2}{216EI} = \frac{2}{9}Mo\ell^2C$	$i_1 = \frac{Mo\ell}{16EI} = 3Mo\ell C$ $i_2 = 0$

$\delta_1$ : deflection at the concentrated load point (mm)  $\delta_{max}$ : maximum deflection (mm)  $i_1$ : deflection angle at the concentrated load point (rad)  $i_2$ : deflection angle at the support point (rad)  $Mo$ : moment (N·mm)  $P$ : concentrated load (N)  $p$ : uniformly distributed load (N/mm)  $a, b$ : concentrated load point distance (mm)  $\ell$ : span (mm)  $I$ : moment of inertia of area (mm<sup>4</sup>) (refer to Table B-8 on page B-8)  $E$ : modulus of longitudinal elasticity (SUJ2)  $2.06 \times 10^5$  (N/mm<sup>2</sup>) (SUS)  $2.0 \times 10^5$  (N/mm<sup>2</sup>)  $C$ :  $1/48EI$  (1/N·mm<sup>2</sup>)

ALLOWABLE ROTATIONAL SPEED OF SPLINE SHAFT

When the rotational speed is increased and approaches the spline shaft resonant frequency, the spline shaft is disabled from further operation. This speed is called the critical speed and can be obtained by the following equations. In order to leave a sufficient safety margin, the allowable operating speed should be set at about 80% of the calculated value.

Using the following equations, select the size of ball spline shaft. First, calculate  $\lambda$  and A by equation (8) and (9) then, substitute the values into equation (7).

$$N_c = 60 \cdot \frac{\lambda^2}{2\pi \cdot L^2} \cdot \sqrt{\frac{E \cdot I_d \times 10^3}{\gamma \cdot A}} \dots\dots\dots (7)$$

$N_c$ : critical speed (rpm)  
 $L$ : support distance (mm)  
 $E$ : modulus of longitudinal elasticity (SUJ2)  $2.06 \times 10^5$  (N/mm<sup>2</sup>)  
 (SUS)  $2.0 \times 10^5$  (N/mm<sup>2</sup>)  
 $\gamma$ : density (SUJ2)  $7.85 \times 10^{-6}$  (kg/mm<sup>3</sup>)  
 (SUS)  $7.75 \times 10^{-6}$  (kg/mm<sup>3</sup>)

$$I_d = \frac{\pi \cdot d^4}{64} \dots\dots\dots (8)$$

$d$ : maximum machined-down diameter with no spline grooves left (refer to Table B-11)

$A$ : Minimum Cross-sectional Area of the Spline Shaft (mm<sup>2</sup>)

$$A = \frac{\pi \cdot d^2}{4} \dots\dots\dots (9)$$

$d$ : maximum machined-down diameter with no spline grooves left (refer to Table B-11)

$\lambda$ : coefficient of mounting method (refer to Figure B-7)

- fixed-free  $\lambda = 1.875$
- supported-supported  $\lambda = 3.142$
- fixed-supported  $\lambda = 3.927$
- fixed-fixed  $\lambda = 4.730$

Table B-11 Spline Shaft Profile

part number	d: maximum diameter with no spline grooves left mm	part number	d: maximum diameter with no spline grooves left mm
SSP 4	3.5	SSP20	16.4
SSP 6	5.3	SSP25	20.6
SSP 8	7.2	SSP30	24.8
SSP 10	9	SSP40	33.1
SSP 13A	11.7	SSP50	41.4
SSP 16A	14.2	SSP60	49.7
SSP 20A	17.9		
SSP 25A	22.4	SSP 4AM	3.4
SSP 30A	26.8	SSP 5AM	4.3
SSP 40A	35.5	SSP 6AM	5.2
SSP 50A	44.6	SSP 8AM	7.1
SSP 60A	54	SSP10AM	8.8
SSP 80A			
SSP 80AL	73.9		
SSP100A			
SSP100AL	92		

The maximum diameter (d) is recommended as the shaft diameter of the support area leaving no spline grooves after end-machining.

Figure B-7 Mounting Method

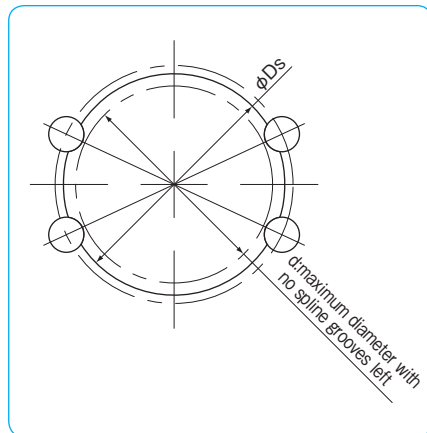
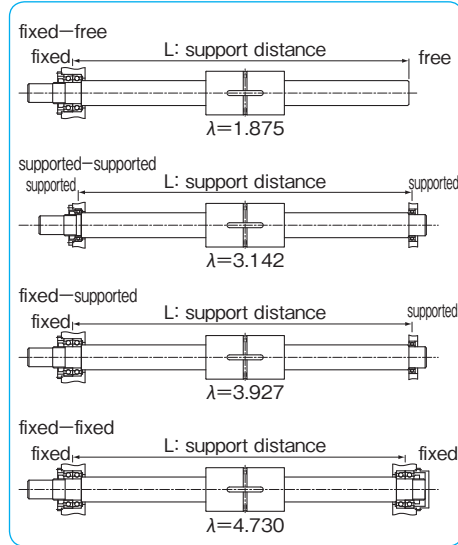

RATED LIFE CALCULATION

When the ball elements are used as the rolling elements in ball splines, the following equations are used to calculate the life of ball spline:

$$\text{For radial load } L = \left( \frac{f_c \cdot C}{f_w \cdot P} \right)^3 \cdot 50 \quad \text{For torque load } L = \left( \frac{f_c \cdot C_T}{f_w \cdot T} \right)^3 \cdot 50$$

$L$ : rated life (km)  $f_c$ : contact coefficient  $f_w$ : load coefficient  
 $C$ : basic dynamic load rating (N)  $P$ : applied load (N)  
 $C_T$ : basic dynamic torque rating (N·m)  $T$ : applied torque (N·m)  
 \* Refer to page Eng-5 for the coefficients  
 \*\* The load rating of the commercial spline is approximately 70% of the standard ball spline.

$$L_h = \frac{L \cdot 10^3}{2 \cdot \ell_s \cdot n_1 \cdot 60}$$

$L_h$ : life time (hr)  $\ell_s$ : stroke length (m)  
 $L$ : rated life (km)  $n_1$ : number of cycles per minute (cpm)

MOUNTING

Fit between Spline Nut and Housing

A transition fit is used for the SSP/SSPM-type spline nut and its housing bore to minimize the clearance. If high accuracy is not required, then a clearance fit can be used. Regarding the SSPT/SSPF type spline nut, for a light load and little torque application a hole slightly larger than the outer diameter of the nut can suffice. The mounting surface for the flange influences the perpendicularity and parallelism. Please make sure that the accuracy of the mounting surface is correct.

Insertion of Spline Nut

When inserting a spline nut into the housing, use a jig like the one shown in Figure B-9. Carefully insert the nut so as to not hit the side ring and seal.

Table B-13 Recommended Jig Dimensions unit: mm

part number	D	d	part number	D	d
SSP 4	9.5	3.5	SSP20	31.5	16.5
SSP 6	13.5	5	SSP25	36.5	20.5
SSP 8	15.5	7	SSP30	44.5	25
SSP 10	20.5	8.5	SSP40	59.5	33
SSP 13A	23.5	12	SSP50	74	41
SSP 16A	30.5	14.5	SSP60	89	50
SSP 20A	34.5	18			
SSP 25A	41.5	22.5	SSP 4AM	7.5	3
SSP 30A	46.5	27	SSP 5AM	9.5	4
SSP 40A	63.5	35.6	SSP 6AM	11.5	5
SSP 50A	79	44	SSP 8AM	14.5	7
SSP 60A	89	53.5	SSP10AM	18.5	8.5
SSP 80A					
SSP 80AL	119	74			
SSP100A					
SSP100AL	149	92			

Figure B-8 Radial Load and Torque Load

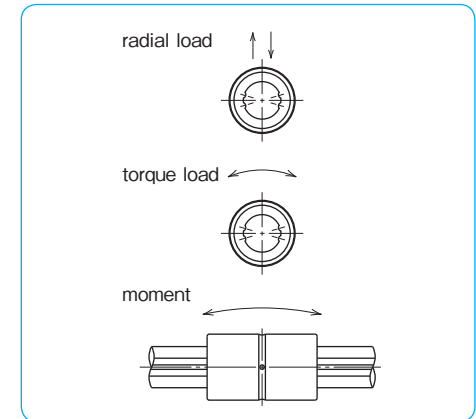
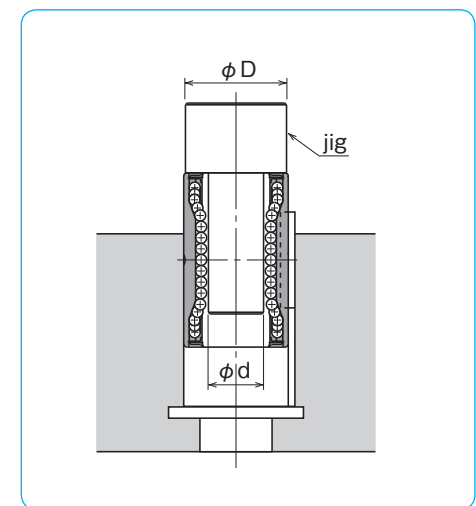

Table B-12 Fit for the Spline Nut

type of spline nut	clearance fit	transition fit
SSP	H7	J6
SSP-AM		
SSPM		

Figure B-9 Insertion of Spline Nut into Housing



## OPERATING CONDITIONS

The performance of the ball spline is affected by the operating conditions of the application. The operating conditions should, therefore be carefully taken into consideration.

### Dust Prevention

Foreign particles or dust in the ball spline nut affects the motion accuracy and shortens the life time. Standard seals will perform well against dust prevention under normal operating conditions; however, in a harsh environment, it is necessary to attach bellows or protective covers. (refer to Figure B-10)

Figure B-10 Example of Dust Prevention

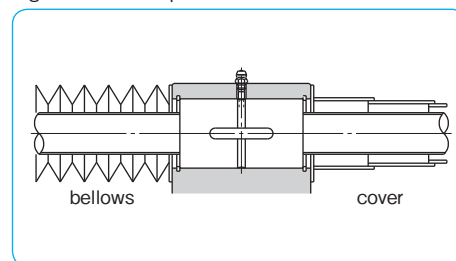

### Operating Temperature

Since the retainer is made of resin, the operating temperature should never exceed 80°C.

## LUBRICATION

The spline nut is prelubricated with lithium soap based grease prior to shipment for immediate use. Please relubricate with a similar type of grease periodically depending on the operating conditions.

Low dust generation grease is available from NB standard grease. (refer to page Eng-40)

The NB spline nut has seals as standard. The seals work well to contain the grease inside the nut especially for the ground shaft, since the seal shape approximates the spline shaft profile.

Figure B-11 Example of Lubrication Mechanism

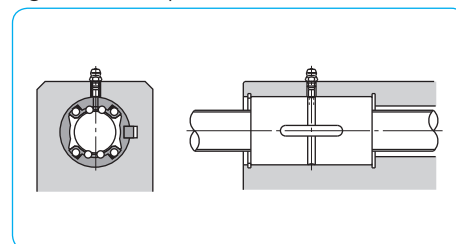

## HOLLOW SPLINE SHAFT

NB provides hollow shafts. It can be used for running cable, air piping, and weight reduction. Table B-12 shows a list of recommended inner diameter for hollow spline shaft (SUJ2).

Table B-14  
Recommended Inner Diameter for Hollow Spline Shaft

part number	shaft diameter Ds mm	inner diameter d mm	cross-sectional coefficient Z mm <sup>3</sup>	second moment of inertia I mm <sup>4</sup>
SSP 4	4	1.5	11.5	5.6
SSP 6	6	2	58.3	18.9
SSP 8	8	3	186	44.9
SSP10	10	4	448	85.9
SSP13A	13	6	1,260	182
SSP16A	16	8	2,780	323
SSP20A	20	10	6,860	637
SSP25A	25	15	15,400	1,100
SSP 4AM	4	1.5	11.6	5.7
SSP 5AM	5	2	26.9	10.3
SSP 6AM	6	2	58.1	18.8
SSP 8AM	8	3	184	44.4
SSP10AM	10	4	440	84.2

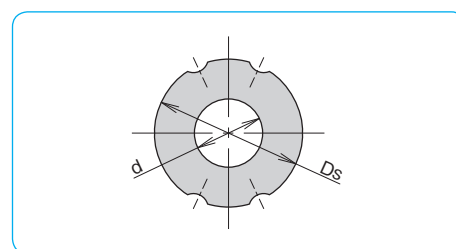

## SPECIAL REQUIREMENTS

Based on customer drawings and requirements NB offers shaft-end machining, spline nut machining, surface treatment, etc. Please contact NB for special requirements.

Figure B-12 Example of Shaft-end Machining

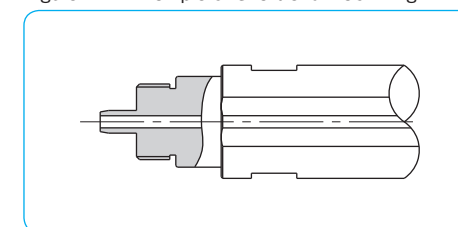

## NUT ORIENTATION

Unless otherwise specified, the orientation of two NB ball spline nuts SSPM, SSPF, SSPT and SSPT(K)-AM type is shown in Figure B-13. In other cases please specify the orientation of nut(s) with shaft.

Figure B-13 Nut Orientation and NB mark

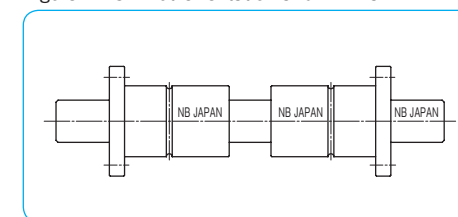

## USE AND HANDLING PRECAUTIONS

NB ball spline must be handled with care as it is a precise component. Please note the following points.

### A Set of Spline Nut and Spline Shaft

The ball spline's accuracy and preload is guaranteed when spline nut and shaft are aligned as shown in Figure B-14. Please make sure to align the NB marks when reinserting the shaft.

When inserting the spline shaft into the spline nut, ensure that the ball elements do not drop out. This is done by aligning the raceway grooves of the shaft with the rows of ball elements and the seal lip of the nut. Then, carefully insert the spline shaft through the spline nut. In case that the nut is preloaded, please exercise additional care.

Figure B-14 NB mark Alignment

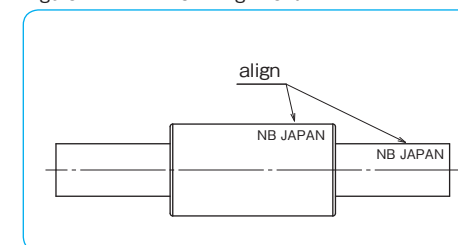

### Excessive Moment

One spline nut can sustain high moments, however, excessive moment makes the spline nut unbalanced and unstable during motion. Please use more than one spline nut for high moment or high accuracy applications.

MOUNTING

Mounting of SSP Type

Examples of installing the SSP type are shown in Figures B-15 and B-16.

Figure B-15 Using a Retaining Ring

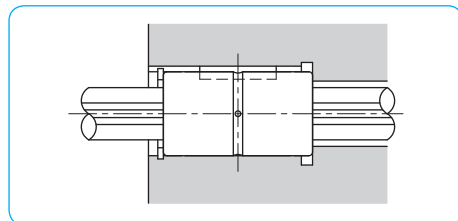
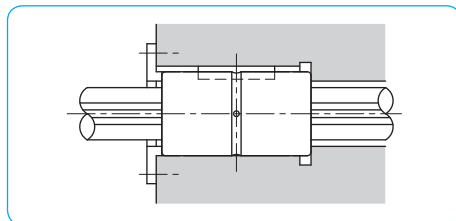

Figure B-16 Using a Push Plate



Key

The SSP and SSP-AM type spline nut come with a key shown in Figure B-17.

Figure B-17 Key for SSP Type

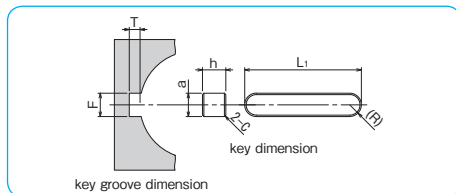

Table B-15 Major Dimensions of Key and Key Groove

part number	key dimensions						recommended key groove dimensions				
	a mm	tolerance μm	h mm	tolerance μm	L <sub>1</sub> mm	C mm	F mm	tolerance μm	T mm	tolerance mm	
SSP 4	2		2		6		2		1		
SSP 6	2.5	+16 + 6	2.5	0 -25	10.5	0.2	2.5	+21 +11	1.5	+0.1 0	
SSP 8	2.5		2.5		10.5		2.5		1.5		
SSP 10	3		3		13		3		1.7		
SSP 13A	3		3		15		3		1.7		
SSP 16A	3.5		3.5		17.5		3.5		1.8		
SSP 20A	4	+24 +12	4	0 -30	29	0.5	4	+30 +18	1.8	+0.2 0	
SSP 25A	4		4		36		0.3		4		1.8
SSP 30A	4		4		42		0.5		4		1.8
SSP 40A	6		6		52		0.5		6		2.8
SSP 50A	8	+30/+15	7	0 -36	58	0.5	8	+37.5/+22.5	3.3	+0.2 0	
SSP 60A	12		8		67		0.8		12		3.3
SSP 80A	16	+36 +18	10		76	0.5	16	+45 +27	4.3		
SSP 80AL					110		4.3				
SSP100A	20	+43 +22	13	0 -43	110	0.8	20	+53.5 +32.5	6.4		
SSP100AL					160		6.4				
SSP 20	4	+24	4	0	26	0.2	4	+30	1.8	+0.1	
SSP 25	5	+12	5	-30	33	0.3	5	+18	2.3	0	
SSP 30	7	+30	7	0	41	0.3	7	+37.5	3.3		
SSP 40	10	+15	8	0	55	0.5	10	+22.5	3.8	+0.2	
SSP 50	15	+36	10	-36	60	0.5	15	+45	5.3	0	
SSP 60	18	+18	11	0/-43	68	0.5	18	+27	5.4		
SSP 5AM	2	+16 + 6	2	0 -25	6	0.2	2	+21 +11	1	+0.1 0	
SSP 6AM	2		2		8		2		1		
SSP 8AM	2.5		2.5		8.5		2.5		1.5		
SSP10AM	3		3		11		3		1.7		

For SSPS and SSP-AM type, the material of key is stainless steel.

Mounting of SSP4AM Type

Example of installing the SSP4AM type are shown in Figure B-18. M2 screw is used for mounting. In process of mounting, please be careful with spline nut.

Figure B-18 Mounting of SSP4AM Type

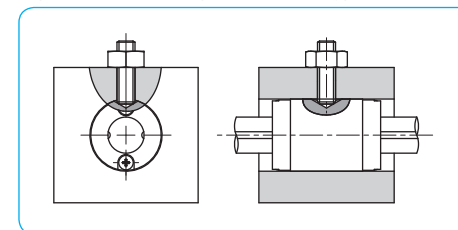

Mounting of SSPM Type

Examples of installing the SSPM type are shown in Figures B-19~24.

Figure B-19 Using F Type Lock Plates

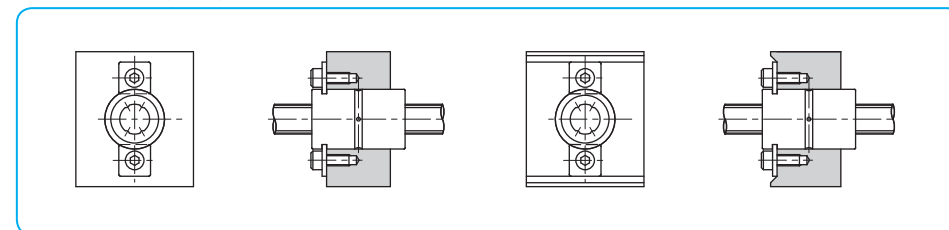

F Type Lock Plate (Standard Plate)

The lock plate shown in Figure B-20 is provided with the SSPM spline nut.  
Material: SUS304CSP

Table B-16 F Type Lock Plate

part number	K mm	G mm	t mm	R mm	applicable spline nut
FP 6	6.8	2.9	1.0	0.5	SSPM 6
FP 8	8.5	3.5	1.2	0.5	SSPM 8
FP10	8.5	3.5	1.2	0.5	SSPM10

Figure B-20 F Type Lock Plate

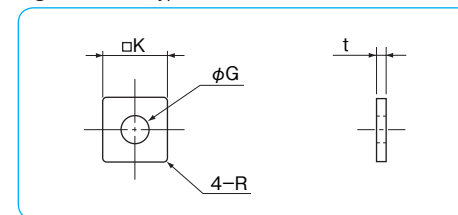
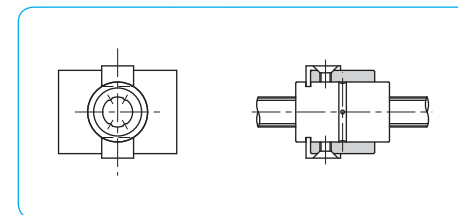

Figure B-21 Using LP Type Lock Plates





**LP Type Lock Plate (Optional Plate)**

The LP type lock plate is also available for purchase with the SSPM spline nut.

**Material: SUS304CSP**

Figure B-22 LP Type Lock Plate

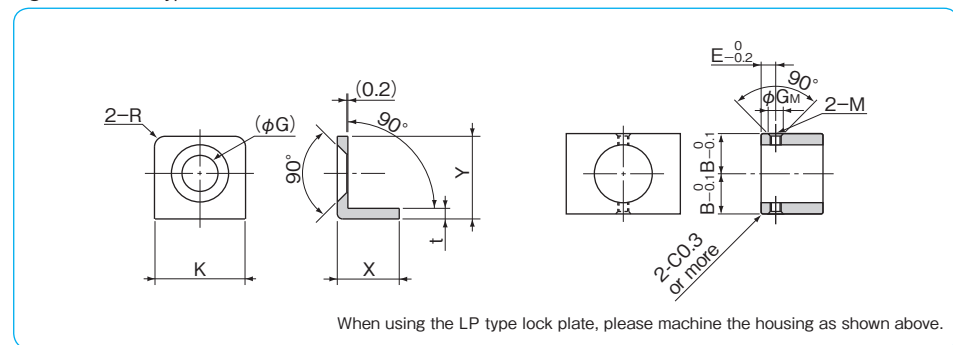

Table B-17 LP Type Lock Plate

part number	lock plate major dimensions						machined housing dimensions				applicable spline nut
	K mm	G mm	t mm	R mm	X mm	Y mm	B mm	E mm	G <sub>M</sub> mm	M	
LP 6	8.6	3.8	1.0	1	5.85	7.8	11.1	3.3	3.5	M2.5	SSPM 6
LP 8	9.15	4.5	1.2	1	6.45	9.2	12.3	4.0	4.2	M3	SSPM 8
LP10	9.15	4.5	1.2	1	6.45	9.2	14.8	4.0	4.2	M3	SSPM10

Figure B-23 Using Special Lock Plates (1)

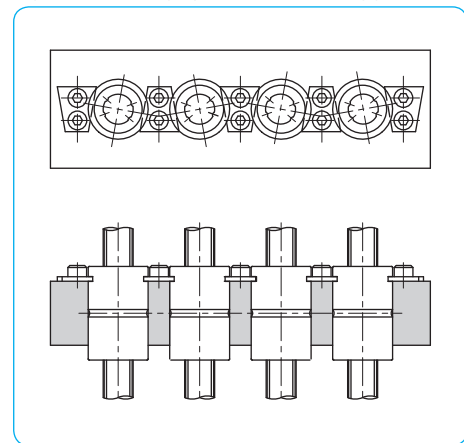
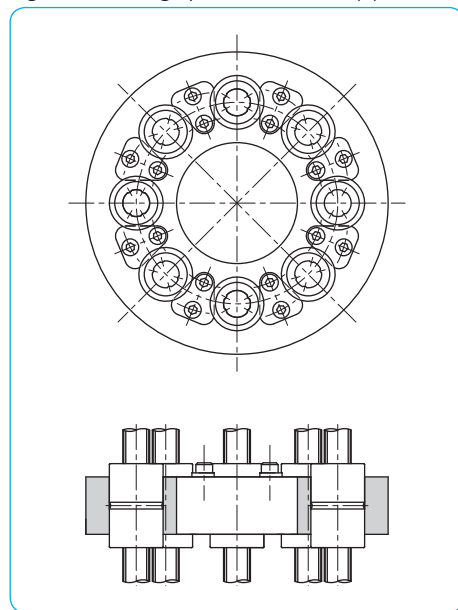

Figure B-24 Using Special Lock Plates (2)



**Mounting of SSPF Type**

Examples of installing the SSPF type are shown in Figure B-25.

Figure B-25 Examples of installing SSPF Type

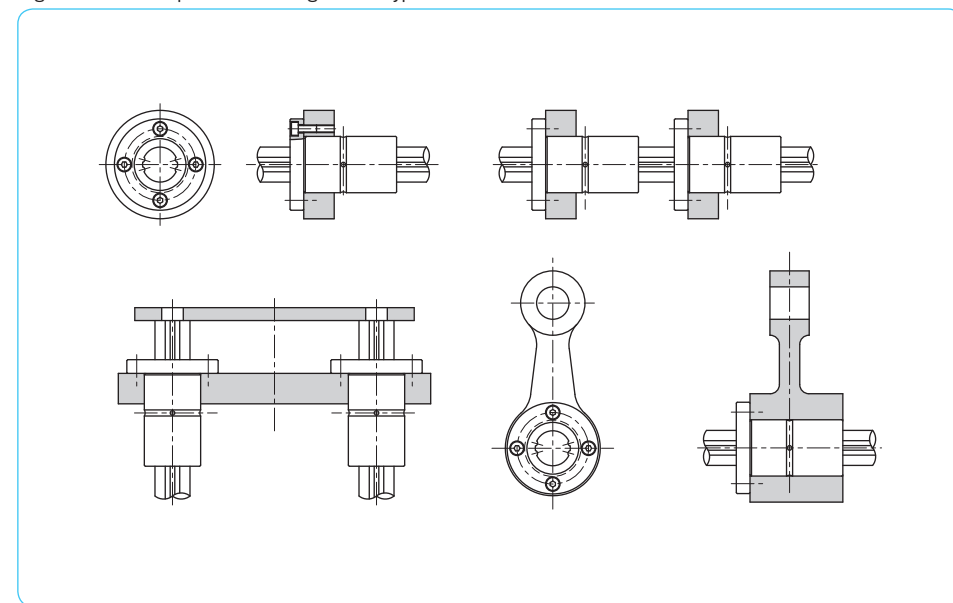

**Mounting of SSPT Type**

Examples of installing SSPT type are shown in Figure B-26.

Figure B-26 Examples of installing SSPT Type

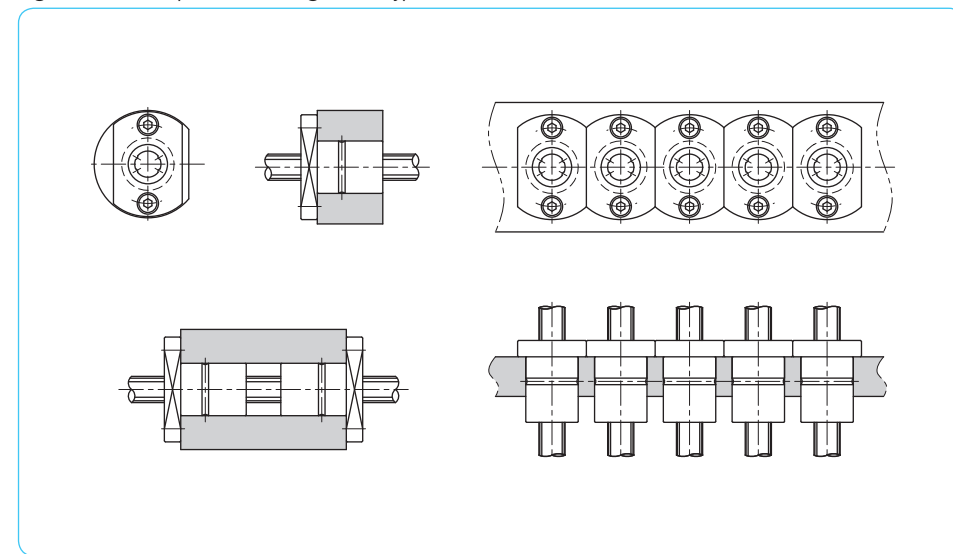

# SSP TYPE

– Cylindrical Spline Nut –

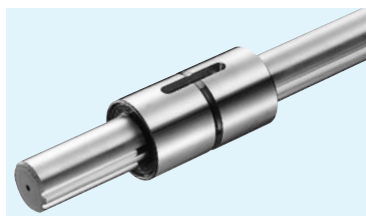

## part number structure

example **SSP 80 L-2-T1-600-P/CU**

specification  
SSP: standard  
SSPS: anti-corrosion

nominal diameter

nut length  
blank: standard  
L: long

number of nuts attached to one shaft

Note: retainer material is resin.

with special specification

accuracy grade  
blank: high  
P: precision

spline shaft total length

preload symbol  
blank: standard  
T1: light  
T2: medium

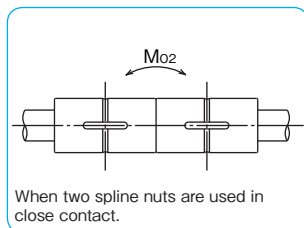

When two spline nuts are used in close contact.

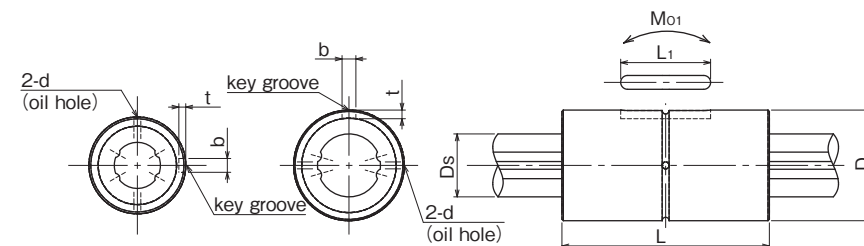

SSP4~10 SSP13A~100AL  
\*SSP4 spline nut does not come with any oil hole.

part number		D mm	tolerance $\mu\text{m}$	L mm	tolerance mm	major dimensions			L <sub>1</sub> mm	d mm
standard	anti-corrosion					b mm	tolerance $\mu\text{m}$	t mm		
SSP 4	SSPS 4	10	0/-9	16	2	2	1.2	6	—	
SSP 6	SSPS 6	14	0	25	2.5	+14	1.2	10.5	1	
SSP 8	SSPS 8	16	-11	25	2.5	0	1.2	10.5	1.5	
SSP 10	SSPS10	21	0	33	3	0	1.5	13	1.5	
SSP 13A	SSPS13A	24	-13	36	3	-0.2	1.5	15	1.5	
SSP 16A	SSPS16A	31	0	50	3.5	0	2	17.5	2	
SSP 20A	SSPS20A	35	0	63	4	+18	2.5	29	2	
SSP 25A	SSPS25A	42	-16	71	4	0	2.5	36	3	
SSP 30A	—	47	0	80	4	0	2.5	42	3	
SSP 40A	—	64	0	100	6	0	3.5	52	4	
SSP 50A	—	80	-19	125	8	+22/0	4	58	4	
SSP 60A	—	90	0	140	12	+27	5	67	4	
SSP 80A	—	120	-22	160	16	0	6	76	5	
SSP 80AL	—	120	0	217	16	0	6	110	5	
SSP100A	—	150	0	185	20	+33	7	110	5	
SSP100AL	—	150	-25	248	20	0	7	160	5	
SSP 20	SSPS20	32	0	60	4	+18	2.5	26	2	
SSP 25	SSPS25	37	-16	70	5	0	3	33	3	
SSP 30	—	45	0	80	7	+22	4	41	3	
SSP 40	—	60	0	100	10	0	4.5	55	4	
SSP 50	—	75	-19	112	15	+27	5	60	4	
SSP 60	—	90	0/-22	127	18	0	6	68	4	

SSP type spline nut comes with a key (refer to page B-14).

D <sub>s</sub> mm	tolerance $\mu\text{m}$	basic torque rating		basic load rating		allowable static moment		mass		size
		dynamic C <sub>T</sub> N·m	static C <sub>0T</sub> N·m	dynamic C kN	static C <sub>0</sub> kN	Mo <sub>1</sub> N·m	Mo <sub>2</sub> N·m	nut kg	shaft kg/m	
4	0	0.74	1.05	0.86	1.22	1.97	10.3	0.0065	0.10	4
6	-12	1.5	2.4	1.22	2.28	5.1	40	0.019	0.21	6
8	0	2.1	3.7	1.45	2.87	7.4	50	0.023	0.38	8
10	-15	4.4	8.2	2.73	5.07	18.0	116	0.054	0.60	10
13	0	21	39.2	2.67	4.89	13.7	109	0.07	1.0	13A
16	-18	60	110	6.12	11.2	46	299	0.15	1.5	16A
20	0	105	194	8.9	16.3	110	560	0.22	2.4	20A
25	-21	189	346	12.8	23.4	171	1,020	0.33	3.7	25A
30	0	307	439	18.6	23.2	181	1,470	0.36	5.38	30A
40	0	674	934	30.8	37.5	358	2,940	0.95	9.55	40A
50	-25	1,290	2,950	40.3	64.9	690	4,080	1.9	15.0	50A
60	0	1,570	3,420	47.7	79.5	881	5,470	2.3	21.6	60A
80	-30	4,500	6,460	92.8	108	1,990	10,500	6.4	39	80A
		5,980	9,690	123	162	4,310	20,980	9.1		80AL
100	0	9,180	12,000	151	160	3,350	18,200	11.2	61	100A
	-35	12,100	18,000	200	240	7,210	35,600	15.8		100AL
18.2	0	83	133	7.84	11.3	63	500	0.2	2.0	20
23	-21	162	239	12.3	16.1	104	830	0.22	3.1	25
28	0	289	412	18.6	23.2	181	1,470	0.35	4.8	30
37.4	0	637	882	30.8	37.5	358	2,940	0.81	8.6	40
47	-25	1,390	3,180	46.1	74.2	696	4,400	1.5	13.1	50
56.5	0/-30	2,100	4,800	58.0	127	1,300	8,800	2.5	19	60

1kN ≒ 102kgf 1N·m ≒ 0.102kgf·m

# SSP-AM TYPE



## part number structure

example **SSP 4 AM-2 T1 -200 P/CU**

specification  
**SSP AM** : standard  
**SSPS AM** : anti-corrosion

nominal diameter

number of nuts attached to one shaft

with special specification

accuracy grade  
**blank** : high  
**P** : precision

spline shaft total length

preload symbol  
**blank** : standard  
**T1** : light

Note: SSP(S)4AM does not come with side-seals.  
 Material of return cap is resin.

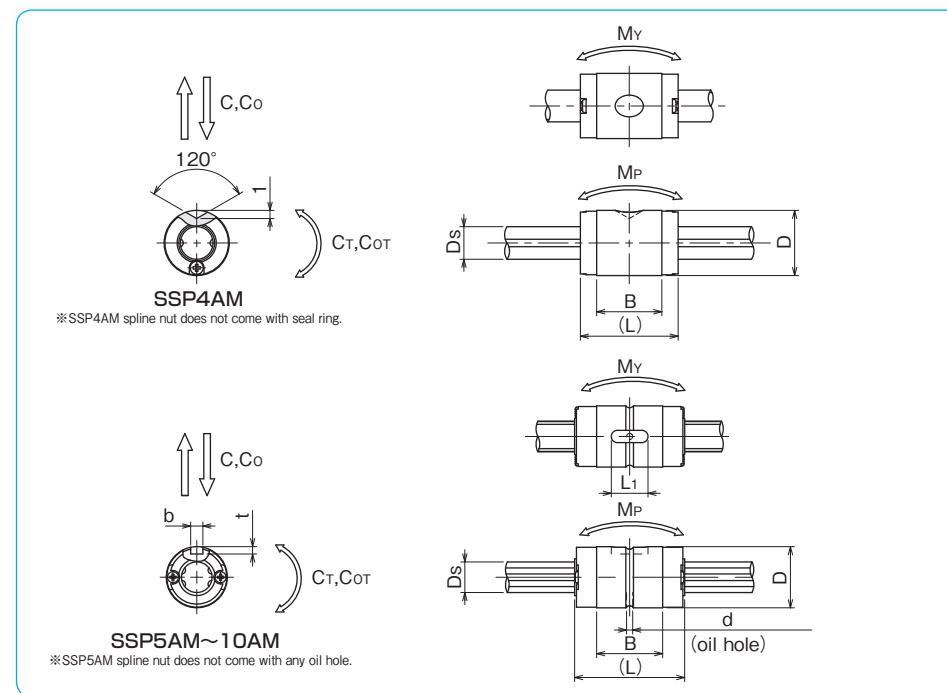
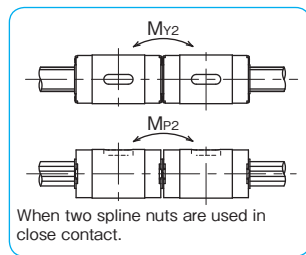

part number		major dimensions										
standard	anti-corrosion	D	L	B	b	t	L <sub>1</sub>	d	D <sub>s</sub>	h7	tolerance	
		mm	mm	mm	mm	mm	mm	mm	mm	mm	μm	
SSP 4AM	SSPS 4AM	8	12	8	—	—	—	—	—	4	0	
SSP 5AM	SSPS 5AM	10	18	10.8	2	1.2	6	—	5	—	-9	
SSP 6AM	SSPS 6AM	12	21	13	2	1.2	8	1	6	—	0	
SSP 8AM	SSPS 8AM	15	25	14.9	2.5	1.5	8.5	1.2	8	—	-11	
SSP10AM	SSPS10AM	19	30	18	3	1.8	11	1.5	10	—	-13	

SSP (S) 5AM-10AM type spline nut come with a key (refer to page B-14).

basic torque rating		basic load rating		allowable static moment		mass		size
dynamic	static	dynamic	static	M <sub>P</sub>	M <sub>Y</sub>	nut	shaft	
C <sub>T</sub>	C <sub>OT</sub>	C	C <sub>O</sub>	M <sub>P2</sub>	M <sub>Y2</sub>	g	g/100mm	
N·m	N·m	N	N	N·m	N·m			
0.72	1.00	314	438	0.59	1.03	2.5	9.7	<b>4AM</b>
2.33	4.05	825	1,160	2.10	2.56	5.1	14.9	<b>5AM</b>
2.95	5.27	890	1,290	2.55	3.11	9.2	21.6	<b>6AM</b>
5.85	9.83	1,330	1,810	4.11	5.00	15.8	38.4	<b>8AM</b>
12.4	19.4	2,270	2,870	7.84	9.53	30.7	59.8	<b>10AM</b>
				52.5	63.9			

Allowable static moment M<sub>P2</sub> and M<sub>Y2</sub> are the values when two spline nuts are used on close contact.

1kN≒102kgf 1N·m≒0.102kgf·m

# SSPM TYPE

– Keyless Spline Nut –

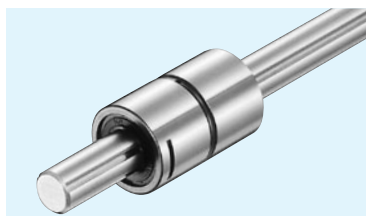

## part number structure

example **SSPM 10-2-T1-200-P/CU**

SSPM type

nominal diameter

number of nuts attached to one shaft

Note: retainer material is resin.

spline shaft total length

with special specification

accuracy grade  
blank: high  
P: precision

preload symbol  
blank: standard  
T1: light

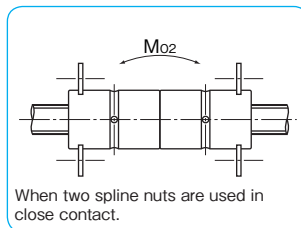

When two spline nuts are used in close contact.

part number	major dimensions											
	D mm	tolerance $\mu\text{m}$	L mm	tolerance mm	F mm	W mm	C mm	A mm	d mm	B mm	H mm	K mm
<b>SSPM 6</b>	14	0	25	0	2.2	1.1	1.0	12.0	1	9.4	25.6	6.8
<b>SSPM 8</b>	16	-11	25	-0.2	2.7	1.3	1.2	13.6	1.5	11	30.6	8.5
<b>SSPM10</b>	21	0/-13	33	-0.2	2.7	1.3	1.2	18.6	1.5	13.5	35.6	8.5

Two F type lock plates per SSPM type spline nut are provided (refer to page B-15).

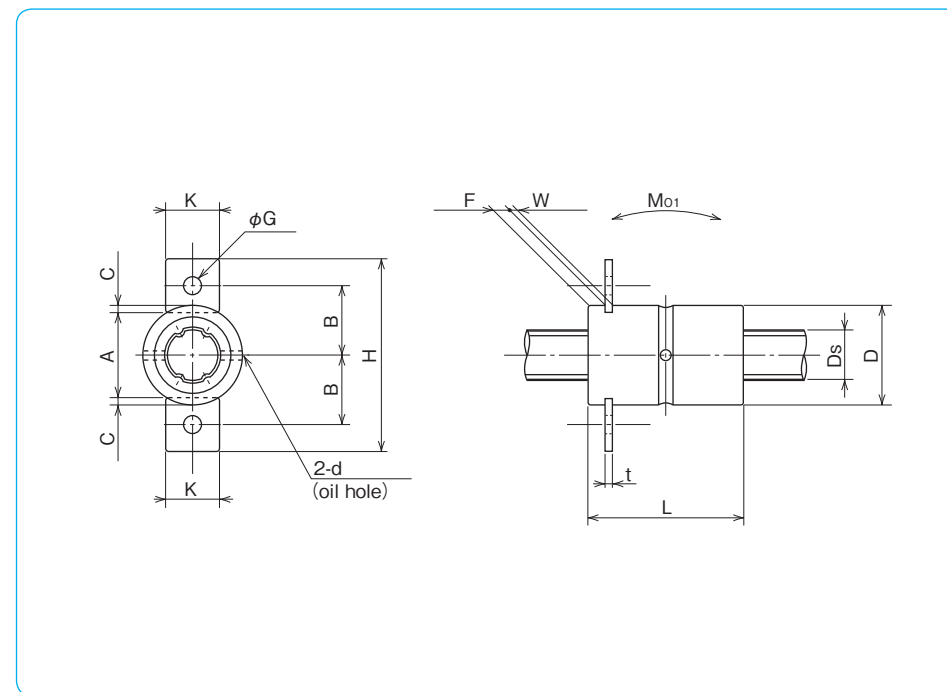

G mm	t mm	Ds mm	tolerance $\mu\text{m}$	basic torque rating		basic load rating		allowable static moment		mass		
				dynamic C $\tau$ N·m	static Co $\tau$ N·m	dynamic C kN	static Co kN	Mo1 N·m	Mo2 N·m	nut kg	shaft kg/m	size
2.9	1.0	6	0/-12	1.5	2.4	1.22	2.28	5.1	40	0.019	0.21	<b>6</b>
3.5	1.2	8	0	2.1	3.7	1.45	2.87	7.4	50	0.023	0.38	<b>8</b>
3.5	1.2	10	-15	4.4	8.2	2.73	5.07	18.0	116	0.054	0.60	<b>10</b>

1kN  $\approx$  102kgf 1N·m  $\approx$  0.102kgf·m

# SSPF TYPE

— Flange Type Nut —

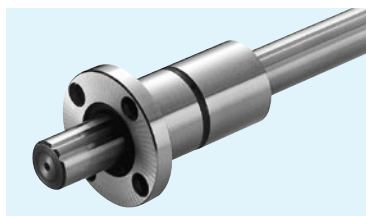

## part number structure

example **SSPF 25 - 2 - T1 - 436 - P / CU**

specification  
SSPF: standard  
SSPFS: anti-corrosion

nominal diameter

number of nuts attached to one shaft

Note: retainer material is resin.

with special specification

accuracy grade  
blank: high  
P: precision

spline shaft total length

preload symbol  
blank: standard  
T1: light  
T2: medium

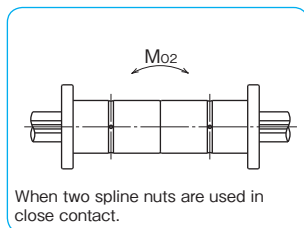

When two spline nuts are used in close contact.

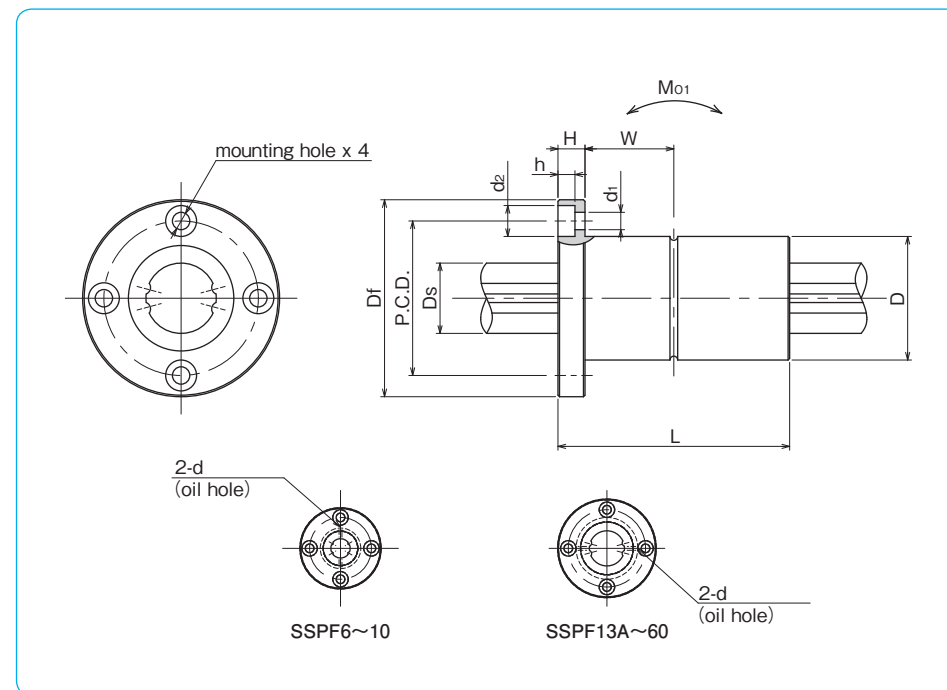

part number		D		L		major dimensions				
standard	anti-corrosion	mm	tolerance $\mu\text{m}$	mm	tolerance mm	Df mm	H mm	P.C.D. mm	$d_1 \times d_2 \times h$ mm	W mm
SSPF 6	SSPFS 6	14	0	25	0	30	5	22	3.4×6.5×3.3	7.5
SSPF 8	SSPFS 8	16	-11	25		32	5	24	3.4×6.5×3.3	7.5
SSPF10	SSPFS10	21	0	33		42	6	32	4.5×8×4.4	10.5
SSPF13A	SSPFS13A	24	-13	36	-0.2	43	7	33	4.5×8×4.4	11
SSPF16A	SSPFS16A	31		50	0	50	7	40	4.5×8×4.4	18
SSPF20A	SSPFS20A	35	0	63		58	9	45	5.5×9.5×5.4	22.5
SSPF25A	SSPFS25A	42	-16	71		65	9	52	5.5×9.5×5.4	26.5
SSPF30A	—	47		80	0	75	10	60	6.6×11×6.5	30
SSPF40A	—	64	0	100		100	14	82	9×14×8.6	36
SSPF50A	—	80	-19	125		-0.3	124	16	102	11×17.5×11
SSPF60A	—	90	0/-22	140		129	18	107	11×17.5×11	52
SSPF20	SSPFS20	32		60	0/-0.2	51	7	40	4.5×8×4.4	23
SSPF25	SSPFS25	37	0	70	0	60	9	47	5.5×9.5×5.4	26
SSPF30	—	45	-16	80		70	10	54	6.6×11×6.5	30
SSPF40	—	60	0	100		-0.3	90	14	72	9×14×8.6
SSPF50	—	75	-19	112		113	16	91	11×17.5×11	40
SSPF60	—	90	0/-22	127		129	18	107	11×17.5×11	45.5

d	Ds	tolerance $\mu\text{m}$	basic torque rating		basic load rating		allowable static moment		mass		size
			dynamic $C_T$ N·m	static $C_{0T}$ N·m	dynamic C kN	static $C_0$ kN	$M_{O1}$ N·m	$M_{O2}$ N·m	nut kg	shaft kg/m	
1	6	0/-12	1.5	2.4	1.22	2.28	5.1	40	0.037	0.21	6
1.5	8	0	2.1	3.7	1.45	2.87	7.4	50	0.042	0.38	8
1.5	10	-15	4.4	8.2	2.73	5.07	18.0	116	0.094	0.6	10
1.5	13	0	21	39.2	2.67	4.89	13.7	109	0.1	1	13A
2	16	-18	60	110	6.12	11.2	46	299	0.2	1.5	16A
2	20		105	194	8.9	16.3	110	560	0.33	2.4	20A
3	25	0	189	346	12.8	23.4	171	1,020	0.45	3.7	25A
3	30	-21	307	439	18.6	23.2	181	1,470	0.55	5.38	30A
4	40	0	674	934	30.8	37.5	358	2,940	1.41	9.55	40A
4	50	-25	1,290	2,950	40.3	64.9	690	4,080	2.73	15.0	50A
4	60	0/-30	1,570	2,620	47.7	79.5	881	5,470	3.2	21.6	60A
2	18.2		83	133	7.84	11.3	63	500	0.22	2	20
3	23	0	162	239	12.3	16.1	104	830	0.32	3.1	25
3	28	-21	289	412	18.6	23.2	181	1,470	0.51	4.8	30
4	37.4	0	637	882	30.8	37.5	358	2,940	1.15	8.6	40
4	47	-25	1,390	3,180	46.1	74.2	696	4,400	2.1	13.1	50
4	56.5	0/-30	2,100	4,800	58.0	127	1,300	8,800	3.3	19	60

1kN=102kgf 1N·m=0.102kgf·m

# SSPT TYPE

– Two Side Cut Flange Type –

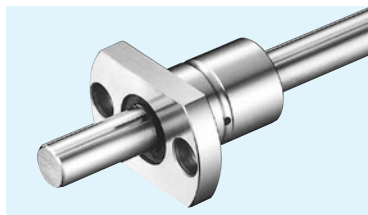

## part number structure

example **SSPT 10-2-T1-436-P/CU**

SSPT type

nominal diameter

number of nuts attached to one shaft

Note: retainer material is resin.

spline shaft total length

preload symbol  
blank: standard  
T1: light

accuracy grade  
blank: high  
P: precision

with special specification

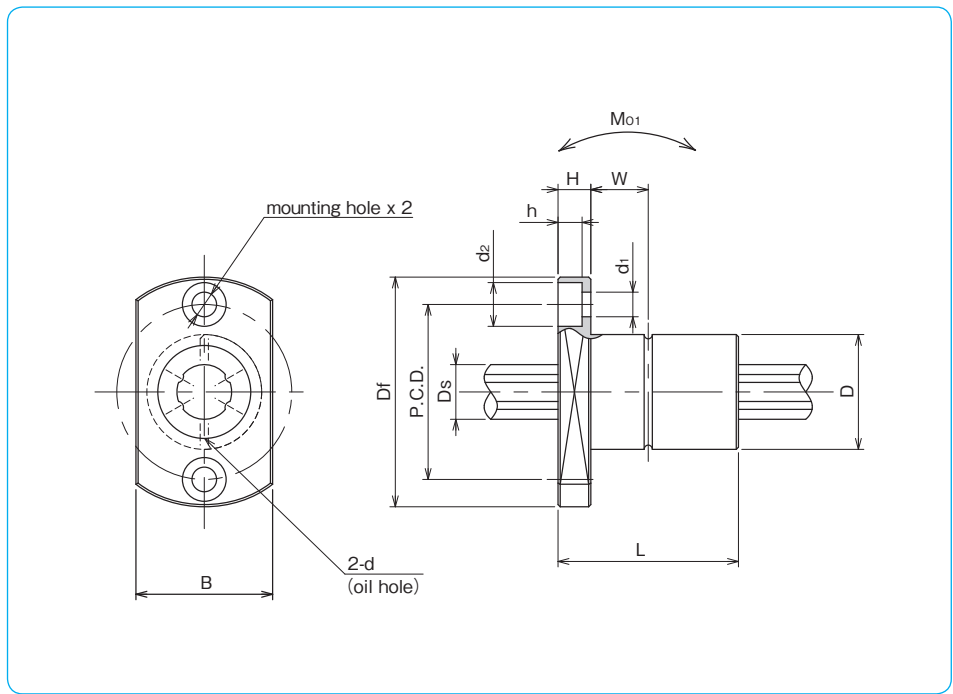
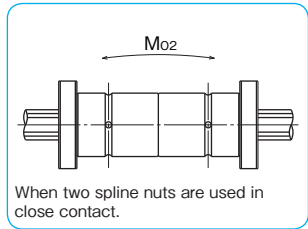

part number	D		L		major dimensions					W
	mm	tolerance μm	mm	tolerance mm	Df mm	B mm	H mm	P.C.D. mm	d <sub>1</sub> × d <sub>2</sub> × h mm	
<b>SSPT 6</b>	14	0	25	0	30	18	5	22	3.4 × 6.5 × 3.3	7.5
<b>SSPT 8</b>	16	-11	25	-0.2	32	21	5	24	3.4 × 6.5 × 3.3	7.5
<b>SSPT 10</b>	21	0/-13	33	-0.2	42	25	6	32	4.5 × 8 × 4.4	10.5

d	D <sub>s</sub>	tolerance μm	basic torque rating		basic load rating		allowable static moment		mass		size
			dynamic C <sub>T</sub>	static C <sub>0T</sub>	dynamic C	static C <sub>0</sub>	Mo <sub>1</sub>	Mo <sub>2</sub>	nut	shaft	
mm	mm	μm	N · m	N · m	kN	kN	N · m	N · m	kg	kg/m	
1	6	0/-12	1.5	2.4	1.22	2.28	5.1	40	0.029	0.21	<b>6</b>
1.5	8	0	2.1	3.7	1.45	2.87	7.4	50	0.035	0.38	<b>8</b>
1.5	10	-15	4.4	8.2	2.73	5.07	18.0	116	0.075	0.6	<b>10</b>

1kN ≒ 102kgf 1N · m ≒ 0.102kgf · m

# SSPT-AM TYPE SSPK-AM TYPE

— Light and Compact Flange Type —



## part number structure

example **SSPK 10 AM-2 T1 400 P/CU**

specification (4AM)  
SSPT AM: standard  
SSPTS AM: anti-corrosion  
(5AM~10AM)  
SSPK AM: standard  
SSPKS AM: anti-corrosion

with special specification

accuracy grade  
blank: high  
P: precision

spline shaft total length

nominal diameter

number of nuts attached to one shaft

preload symbol  
blank: standard  
T1: light

Note: Nut material of SSPT-AM and SSPK-AM is stainless steel.

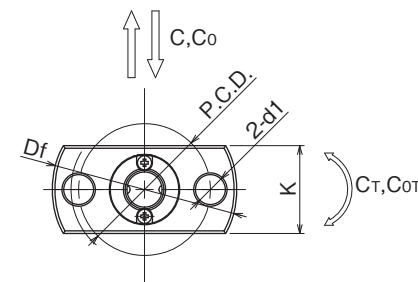

SSPT4AM  
\*SSPT4AM spline nut does not come with seal ring.

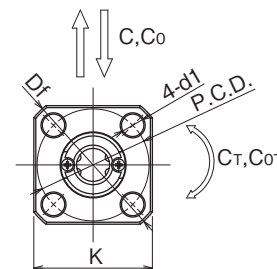

SSPK5AM~10AM  
\*SSPK5AM spline nut does not come with oil groove.

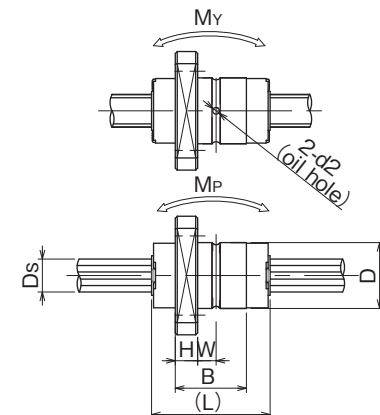
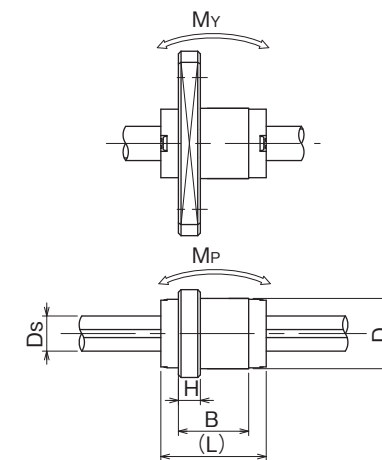

part number		major dimensions									
standard	anti-corrosion	D h6 tolerance	L	B	Df	K	H	P.C.D.	d1	W	
mm	mm	mm	mm	mm	mm	mm	mm	mm	mm	mm	
SSPT 4AM	SSPTS 4AM	8	0	12	8	21	10	2.5	15	3.4	—
SSPK 5AM	SSPKS 5AM	10	-9	18	10.8	23	18	3.4	17	3.4	2.8
SSPK 6AM	SSPKS 6AM	12	0	21	13	25	20	3	19	3.4	3.5
SSPK 8AM	SSPKS 8AM	15	-11	25	14.9	28	22	3.95	22	3.4	3.5
SSPK10AM	SSPKS10AM	19	0 -13	30	18	36	28	4	28	4.5	5

d2	Ds h7 tolerance	basic torque rating		basic load rating		allowable static moment		mass		size	
		dynamic C <sub>T</sub>	static Co <sub>T</sub>	dynamic C	static Co	static moment M <sub>P</sub> N·m	static moment M <sub>V2</sub> N·m	nut g	shaft g/100mm		
mm	mm	μm	N·m	N·m	N	N	N·m	N·m	g	g/100mm	
—	4	0	0.72	1.00	314	438	0.59 3.36	1.03 5.82	5.0	9.7	4AM
1	5	-12	2.33	4.05	825	1,160	2.10 13.4	2.56 16.3	10.7	14.9	5AM
1	6	0	2.95	5.27	890	1,290	2.55 16.5	3.11 20.1	14.7	21.6	6AM
1.2	8	0	5.85	9.83	1,330	1,810	4.11 27.8	5.00 33.8	23.9	38.4	8AM
1.5	10	-15	12.4	19.4	2,270	2,870	7.84 52.5	9.53 63.9	44.0	59.8	10AM

Allowable static moment M<sub>P2</sub> and M<sub>V2</sub> are the values when two spline nuts are used in close contact. 1N≒102gf 1N·m≒102gf·m

STANDARD AND MAXIMUM LENGTH

Standard and maximum length of NB ball spline shaft are shown in Table B-18.

Table B-18 Standard and Maximum Length of SSP Type

unit : mm

size	standard length					maximum length	
						high-grade	precision-grade P
4	100	150	200	300		315	200
5	150	200	300	400		400	315
6	150	200	300	400		400	315
8	150	200	300	400	500	500	400
10	200	300	400	500	600	630	630
13A	200	300	400	500	600	1,500	1,500
16A	200	300	400	500	600	1,500	1,500
20A	300	500	1,000				
25A	300	500	1,000				
30A	300	500	1,000				
40A	500	1,000					
50A	500	1,000					
60A	500	1,000					
80A	—						
80AL	—						
100A	—						
100AL	—						
20	300	500	1,000				
25	300	500	1,000				
30	300	500	1,000				
40	500	1,000					
50	500	1,000					
60	500	1,000					

• Applicable to rotary ball spline SPR, SPB-KP, SPB type and stroke spline SPLFS type, except for precision-grade of SPR and SPLFS type.

• Please contact NB for shaft lengths exceeding maximum length.

COMMERCIAL BALL SPLINE

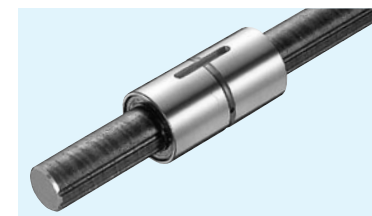

part number structure

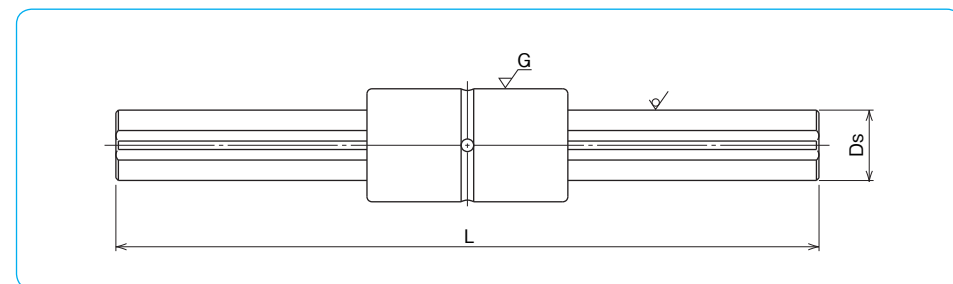
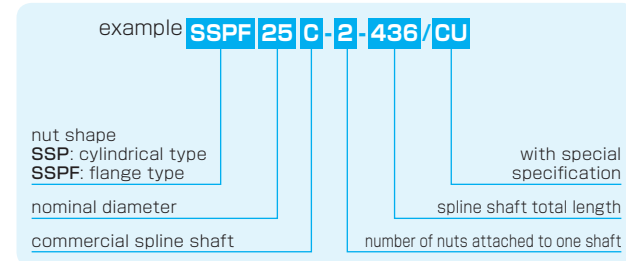

nominal diameter	Ds mm	major dimensions						applicable nut	
		standard length						SSP	SPLFS
		L mm							
20A	20	500	1,000	2,000	3,000	4,000	5,000	○	○
25A	25	500	1,000	2,000	3,000	4,000	5,000	○	○
30A	30	500	1,000	2,000	3,000	4,000	5,000	○	○
40A	40	500	1,000	2,000	3,000	4,000	5,000	○	○
50A	50	500	1,000	2,000	3,000	4,000	5,000	○	○
20	18.2	500	1,000	2,000	3,000	4,000	5,000	○	○
25	23	500	1,000	2,000	3,000	4,000	5,000	○	○
30	28	500	1,000	2,000	3,000	4,000	5,000	○	○
40	37.4	500	1,000	2,000	3,000	4,000	5,000	○	○
50	47	500	1,000	2,000	3,000	4,000	5,000	○	○

• Tolerance of total length  
total length up to 4,000: JIS B0405 coarse grade  
total length greater than 4,000: ±5.0mm  
Please specify tolerances when required.

• Please refer to dimension tables for nut shape and dimensions.

• When a commercial shaft is used, the load rating of the nut is approximately 70% of indicated rating in the dimension tables.

○ yes — no



# ROTARY BALL SPLINE

The NB rotary ball spline can be used for both rotational motion and linear motion. The applications include SCARA robots, vertical shaft of assembly equipment, tool changers, and loaders, etc.

## STRUCTURE AND ADVANTAGES

The NB Rotary Ball Spline nut consists of a spline nut and a rotating portion using either cross rollers for SPR or balls for SPB.

### High Accuracy

Ball Splines transfer torque and achieve accurate positioning in the linear direction. By adding the rotating portion, Rotary Ball Splines can achieve accurate positioning in the linear and rotational directions.

### Half the Parts, Reduction in Installation Cost

The Spline nut and rotary bearing are combined in order to significantly reduce the number of parts, compared to conventional system. The combination also reduces the housing thickness to a minimum, resulting in light weight and easy installation.

Figure B-27 Structure of SPR type

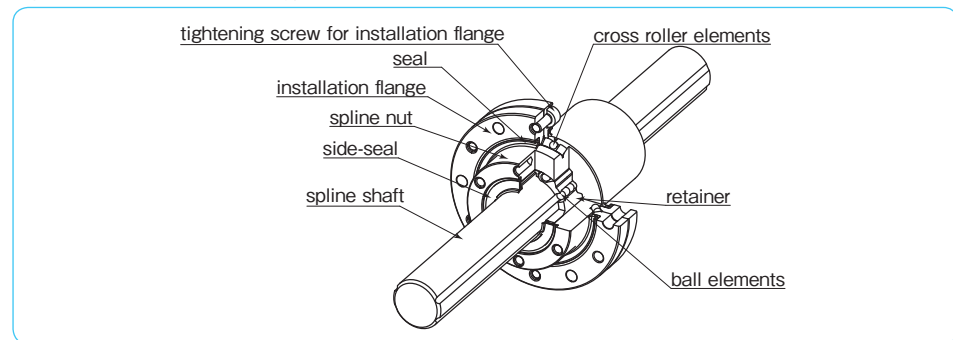
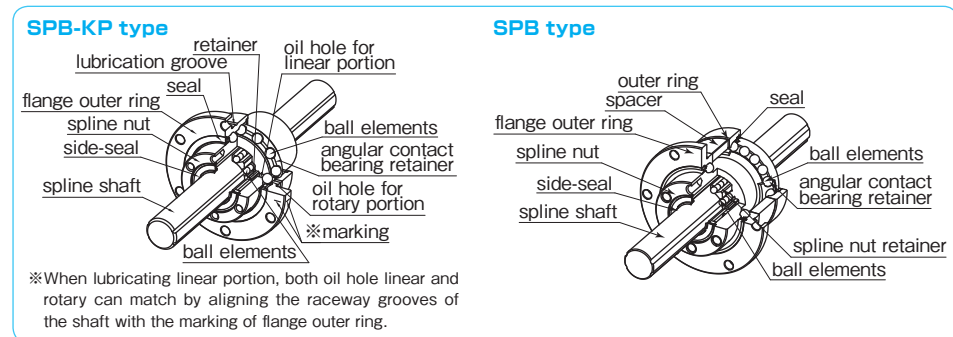

Figure B-28 Structure of SPB-KP type and SPB type



## ACCURACY OF SPR TYPE

The accuracy of SPR type is measured at the points shown in Figure B-29.

Figure B-29 Accuracy Measurement Points

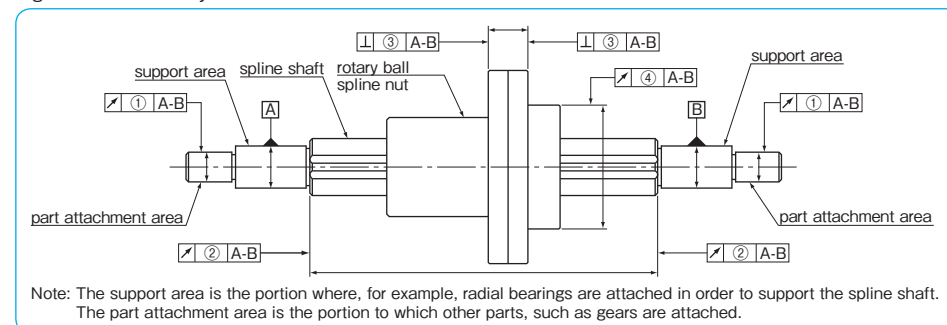

### Tolerance of Spline Shaft Groove Torsion (Max.)

The groove torsion is indicated per 100mm, arbitrarily set as the effective length of the spline shaft section.

Table B-19 Tolerance of Spline Shaft Groove Torsion (Max.)

tolerance
13 μm/100mm

Table B-20 Tolerance Relative to Spline Support Area (Max.)

unit : μm

part number	①radial runout of part attachment area	②radial runout of the end of the spline shaft section (when grinding is requested on the drawing)	③perpendicularity of the flange
SPR 6	14	9	14
SPR 8			
SPR10			
SPR13			
SPR16	19	11	18
SPR20A			
SPR25A			
SPR30A			
SPR40A			
SPR50A			
SPR60A	29	19	29
SPR20			
SPR25			
SPR30			
SPR40			
SPR50			
SPR60	29	19	29

Table B-21 ④Radial Runout of Outer Surface of Rotary Spline Nut Relative to Spline Support Area (Max.)

unit : μm

spline shaft total length (mm) greater than or less	size					
	6, 8	10	13, 16, 20A, 20	25A, 25, 30A, 30	40A, 40, 50A, 50	60A, 60
—	200	46	36	34	32	30
200	315	89	54	45	39	34
315	400	126	68	53	44	36
400	500	163*	82	62	50	38
500	630	—	102	75	57	41
630	800	—	—	92	68	45
800	1,000	—	—	115	83	51
1,000	1,250	—	—	153	102	59
1,250	1,600	—	—	256**	210	70
1,600	2,000	—	—	394	311	179

※Please contact NB for spline shafts exceeding 2000mm. \* SPR6 shaft Max. length: 400mm SPR13, SPR16 Max.length: 1500mm

ACCURACY OF SPB TYPE

The accuracy of SPB type is measured at the points shown in Figure B-30.

Figure B-30 Accuracy Measurement Points

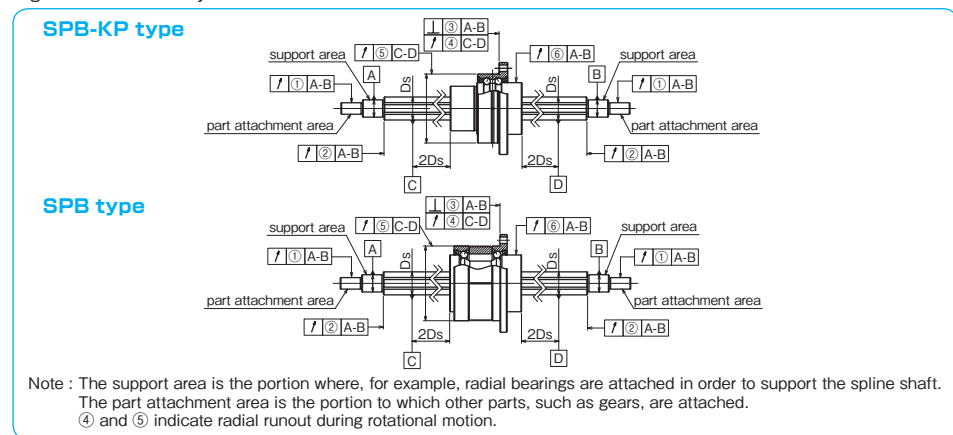

Tolerance of Spline Shaft Groove Torsion (Max.)

The groove torsion is indicated per 100mm, arbitrarily set as the effective length of the spline shaft section.

Table B-22 Tolerance of Spline Shaft Groove Torsion (Max.)

accuracy grade	high	precision (P)
tolerance	13 μm/100mm	6 μm/100mm

Table B-23 Tolerance Relative to Spline Support Area (Max.)

unit : μ m

part number	①radial runout of part attachment area		②radial runout of the end of the spline shaft section (when grinding is requested on the drawing)		③perpendicularity of the flange	
	high-grade	precision-grade (P)	high-grade	precision-grade (P)	high-grade	precision-grade (P)
SPB 6KP	14	8	9	6	14	10
SPB 8KP						
SPB10KP	17	10	11	8	18	13
SPB13KP						
SPB16KP,16						
SPB20KP,20	19	12	13	9	21	16
SPB25KP,25						

Table B-24 Tolerance of Angular Contact Bearing Rotation (Max.) unit : μ m

part number	④runout of flange mounting side		⑤radial runout of outer ring	
	high-grade	precision-grade (P)	high-grade	precision-grade (P)
SPB 6KP	6	6	8	8
SPB 8KP				
SPB10KP				
SPB13KP	8	8	9	9
SPB16KP,16				
SPB20KP,20			10	10
SPB25KP,25				

Table B-25 ⑥Radial Runout of Spline Nut Relative to Spline Support Area (Max.) unit : μ m

spline shaft total length (mm)	size	size													
		6	8	10	13,16,20	25	6	8	10	13,16,20	25				
greater than	or less	high-grade	precision-grade (P)	high-grade	precision-grade (P)	high-grade	precision-grade (P)	high-grade	precision-grade (P)	high-grade	precision-grade (P)	high-grade	precision-grade (P)	high-grade	precision-grade (P)
200	200	46	26	46	26	36	20	34	18	32	18	—	—	—	—
315	315	89	57	89	57	54	32	45	25	39	21	—	—	—	—
400	400	126	—	126	82	68	41	53	31	44	25	—	—	—	—
500	500	—	—	163	—	82	51	62	38	50	29	—	—	—	—
630	630	—	—	—	—	102	65	75	46	57	34	—	—	—	—
800	800	—	—	—	—	—	—	92	58	68	42	—	—	—	—
1,000	1,000	—	—	—	—	—	—	115	75	83	52	—	—	—	—
1,250	1,250	—	—	—	—	—	—	153	97	102	65	—	—	—	—
1,600	1,600	—	—	—	—	—	—	256	180	210	140	—	—	—	—
2,000	2,000	—	—	—	—	—	—	394	314	311	241	—	—	—	—

\*SPB16, 13KP, and 16KP shaft maximum length : 1,500mm  
 \*\*Please contact NB for spline shafts exceeding 2,000mm.

PRELOAD AND CLEARANCE

Preload and clearance of linear motion are available with a standard preload(blank), light preload(T1), and medium preload(T2).

Table B-26 Preload and Clearance of SPR Type unit : μ m

part number	standard	light (T1)	medium (T2)
SPR 6	-2~+1	-6~-2	-
SPR 8			
SPR10	-3~+1	-8~-3	-13~-8
SPR13			
SPR16			
SPR20A	-4~+2	-12~-4	-20~-12
SPR25A			
SPR30A			
SPR40A			
SPR50A	-6~+3	-18~-6	-30~-18
SPR60A			
SPR20	-4~+2	-12~-4	-20~-12
SPR25			
SPR30	-6~+3	-18~-6	-30~-18
SPR40			
SPR50			
SPR60			

Table B-27 Preload and Clearance of SPB-KP and SPB Type (Linear Motion) unit : μ m

part number	standard	light (T1)	medium (T2)
SPB 6KP	0~+3	-3~0	-
SPB 8KP			
SPB10KP	-3~+1	-8~-3	-13~-8
SPB13KP			
SPB16KP,16			
SPB20KP,20	-4~+2	-12~-4	-20~-12
SPB25KP,25			

Please contact NB for other than preload standards above.

Table B-28 Preload and Operating Conditions

preload	symbol	operating conditions
standard	blank	minute vibration is applied. a precise motion is required. moment is applied in a given direction.
light	T1	light vibration is applied. light torsional load is applied. cyclic torque is applied.
medium	T2	shock/vibration is applied. over-hang load is applied. torsional load is applied.

※Frictional resistance may be affected by preload.

HOLLOW SPLINE SHAFT

NB provides hollow shafts. It can be used for running cable, air piping, and weight reduction. Table B-29 shows a list of recommended inner diameter for hollow spline shaft (SUJ2).

Table B-29 Recommended Inner Diameter for Hollow Spline Shaft

part number	outer diameter Ds mm	inner diameter d mm	second moment of inertia I mm <sup>4</sup>	cross-sectional coefficient Z mm <sup>3</sup>
SPR 6	6	2	58.3	18.9
SPR 8	8	3	186	44.9
SPR10	10	4	448	85.9
SPR13	13	6	1,260	182
SPR16	16	8	2,780	323
SPR20A	20	10	6,860	637
SPR25A	25	15	15,400	1,100

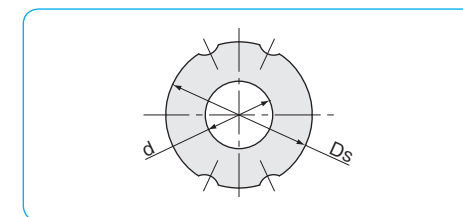

SPECIAL REQUIREMENTS

NB provides customization such as shaft-end machining, spline nut machining, and surface treatment per customer request. Please contact NB for the inner diameter of SPR20~SPR60.

Figure B-31 Examples of Shaft-end Machining

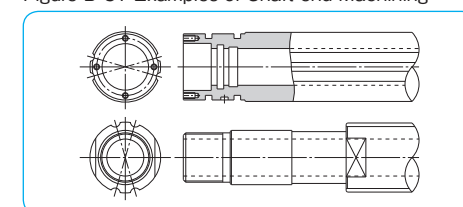

**MOUNTING**

The flange attachment screws of SPR type have been pre-adjusted for smooth rotary movement and should never be loosened. Shock loading to the flange assembly should be avoided as this can degrade the accuracy of movement and deteriorate the overall performance. The spacer of SPB type is properly adjusted to produce the best preload condition. Shock loading to the spacer should be avoided as this can change the preload condition and deteriorate the accuracy. Please fix the mounting screws diagonally. The recommended torque values for medium-hardness steel screws are listed in Table B-30.

Table B-30 Recommended Torque unit : N·m

mounting screw	M2	M2.5	M3	M4	M5	M6	M8
recommended torque	0.4	0.9	1.4	3.2	6.6	11.2	27.6

(for alloy steel screw)

**SPR Type**

When the flange of SPR type is to be used with a faucet joint (as shown in Figure B-32) the housing bore should be machined to a tolerance of H7 and to a minimum depth of 60% of the flange thickness. If only a light load is applied to the SPR in operation, the flange can be used without a pilot end.

Figure B-32 SPR type Mounting Method

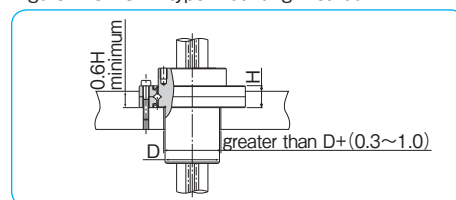

Figure B-33 SPB-KP type Mounting Method

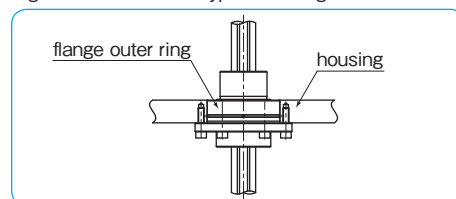
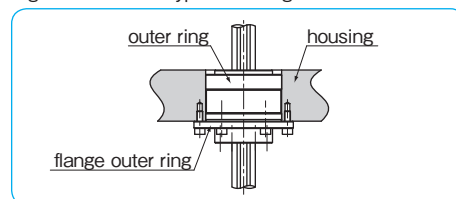

Figure B-34 SPB type Mounting Method



**SPB-KP Type**

The housing bore for the SPB-KP type should be matched to a tolerance of H7 and keep enough depth ( as shown in Figure B-33) so that the outer ring is inside the housing.

**SPB Type**

The housing bore for the SPB type should be machined to a tolerance of H7 and contain enough depth so that the outer ring is inside the housing. If not, the outer ring may fall off.

**Insertion of Spline Shaft**

When inserting the spline shaft into the rotary ball spline nut, ensure that the ball elements do not drop out. This is done by aligning the raceway grooves of the shaft with the rows of ball elements and seal-lip of the nut. Then, carefully insert the spline shaft through the spline nut.

**LUBRICATION**

Since NB rotary ball spline nuts are equipped with seals at both the spline portion and the rotational portion, the lubricant is retained for an extended period of time. The spline nut is prelubricated with lithium soap based grease prior to shipment for immediate use. Please relubricate with a similar type of grease periodically depending on the operating conditions. Low dust generation grease is available from NB standard grease. (refer to page Eng-40) However, an oil lubricant is recommended for high-speed applications. A grease fitting or machining oil holes is optional (Figure B-35-38), please contact NB for details.

**SPR Type**

A grease fitting for rotational portion and machining oil hole for spline portion are optional.

Figure B-35 Example of Installed Grease Fitting

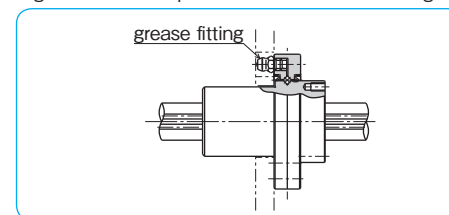
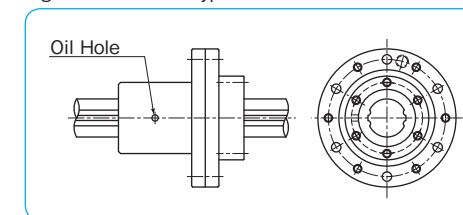

Figure B-36 SPR type Oil Hole



**SPB-KP Type**

Lubrication is done through oil hole on the outer ring. It is applied the spline portion and the cross roller portion simultaneously.

Figure B-37 SPB-KP type Oil Hole

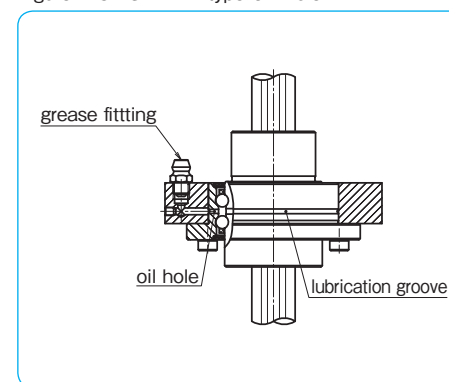

**SPB Type**

Rotational portion has an oil hole as a standard. For lubrication, it is recommended to mount a grease fitting or oil hole to housing. Machining oil hole for spline portion is available. Please contact NB.

Figure B-38 SPB type Oil Hole

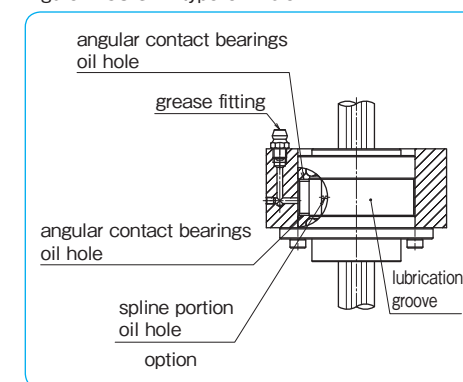

## NUT ORIENTATION

Unless otherwise specified, the orientation of two nuts SPR, SPB-KP and SPB type is shown in Figure B-39. In other cases please specify the orientation of nut(s) with shaft.

Figure B-39 Nut Orientation and NB mark

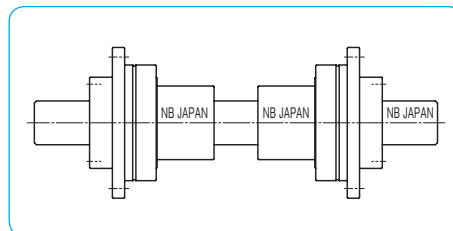

## OPERATING CONDITIONS

### A Set of Spline Nut and Spline Shaft

The ball spline's accuracy and preload is guaranteed when spline nut and shaft are aligned as shown in Figure B-40. Please make sure to align the NB marks when reinserting the shaft.

At this time, both NB marks on the nut and shaft should be aligned in the same direction as when delivered.

When inserting the spline shaft into the spline nut, ensure that the ball elements do not drop out. This is done by aligning the reaway grooves of the shaft with the rows of ball elements and the seal lip of the nut. Then, carefully insert the spline shaft through the spline nut. In case that the nut is preloaded, please exercise additional care. And also, do not disassemble the spline nut.

### SPR Type

Please do not loosen the fastening screws for installation flange. The fastening screws are properly adjusted. Please handle with great care, the accuracy is affected if an excessive impact is applied.

### SPB Type

Please do not adjust the spacer. The spacer is adjusted to provide a proper spacing for the best preload condition. Please handle with great care, the accuracy is affected if the spacer is slipped by an impact, etc..

### Operating Temperature

Resin retainers are used in the rotary ball spline, since the operating temperature should never exceed 80°C.

### Dust Prevention

Foreign particles or dust in the rotary ball spline nut affect the motion accuracy and shorten the lifetime. Standard seals will perform well for dust prevention under normal operating conditions; however, in a harsh environment, it is necessary to attach bellows or protective covers.

Figure B-40 NB mark Alignment

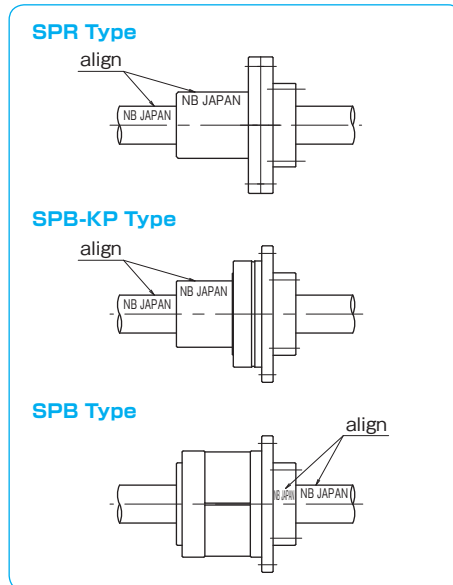

## APPLICATION EXAMPLES

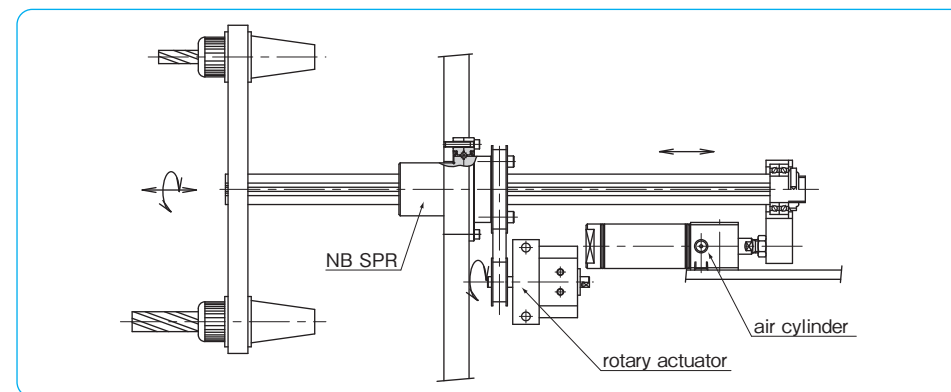
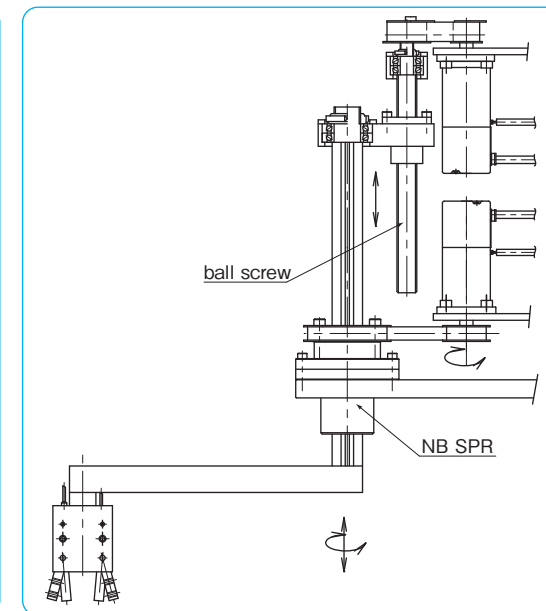
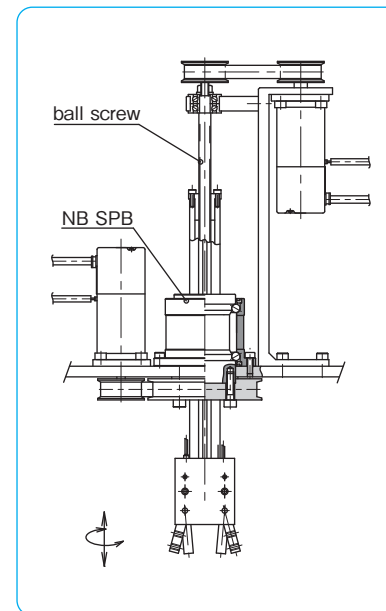

SPR TYPE

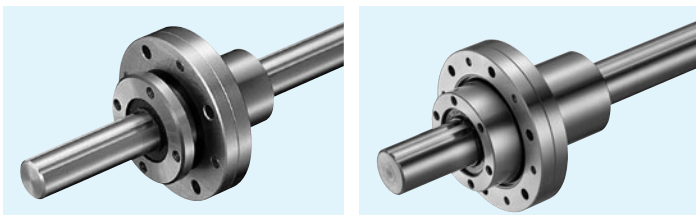

part number structure

example **SPR 25 - 2 - T1 - 436 / CU**

SPR type

nominal diameter

number of nuts attached to one shaft

Note: retainer material is resin.

spline shaft total length

preload symbol  
blank: standard  
T1: light  
T2: medium

with special specification

part number	major dimensions					major dimensions of cross roller bearing											
	D <sub>1</sub>		D <sub>2</sub>	L	tolerance	P <sub>1</sub>	S	h	I	H	D <sub>3</sub>		P <sub>2</sub>	d	G	F	θ
	mm	μm	mm	mm		mm	mm	mm	mm	mm	mm	μm	mm	mm	mm	mm	mm
SPR 6	20		13	25		16	M2	2.5	5	6.5	30	0/-21	24	2.4	M3	5	20°
SPR 8	22	0	15	25	0	18	M2.5	3	6	6.5	33	0	27	2.9	M3	5	20°
SPR10	27	-21	19	33	0	22	M3	4	8	7	40	-25	33	3.4	M3	5	20°
SPR13	29		24	36	-0.2	24	M3	5	8	9	50		42	3.4	M3	5	15°
SPR16	36	0	31	50		30	M4	6	10	11	60	0	50	4.5	M3	5	15°
SPR20A	44	-25	35	63		38	M4	7	12	13	72	-30	62	4.5	M6×0.75	5.5	15°
SPR25A	55		42	71		47	M5	8	13	16	82		72	4.5	M6×0.75	7	15°
SPR30A	61	0	47	80	0	52	M6	10	17	17	100	0	86	6.6	M6×0.75	7.5	15°
SPR40A	76	-30	64	100	-0.3	66	M6	10	23	20	120	-35	104	9	M6×0.75	9	15°
SPR50A	92	0	80	125		80	M8	13	24	22	134	0	118	9	M6×0.75	10	15°
SPR60A	107	-35	90	140		95	M8	13	25	25	155	-40	137	9	M6×0.75	11.5	15°
SPR20	40	0	34	60	0/-0.2	34	M4	7	12	13	66	0	56	4.5	M6×0.75	5.5	15°
SPR25	50	-25	40	70		42	M5	8	13	16	78	-30	68	4.5	M6×0.75	7	15°
SPR30	61	0	47	80	0	52	M6	10	17	17	100	0	86	6.6	M6×0.75	7.5	15°
SPR40	76	-30	62	100	-0.3	64	M6	10	23	20	120	-35	104	9	M6×0.75	9	15°
SPR50	88	0	75	112		77	M8	13	24	22	130	0	114	9	M6×0.75	10	15°
SPR60	102	-35	90	127		90	M8	13	25	25	150	-40	132	9	M6×0.75	11.5	15°

Please contact NB for the grease fitting and relubrication method.

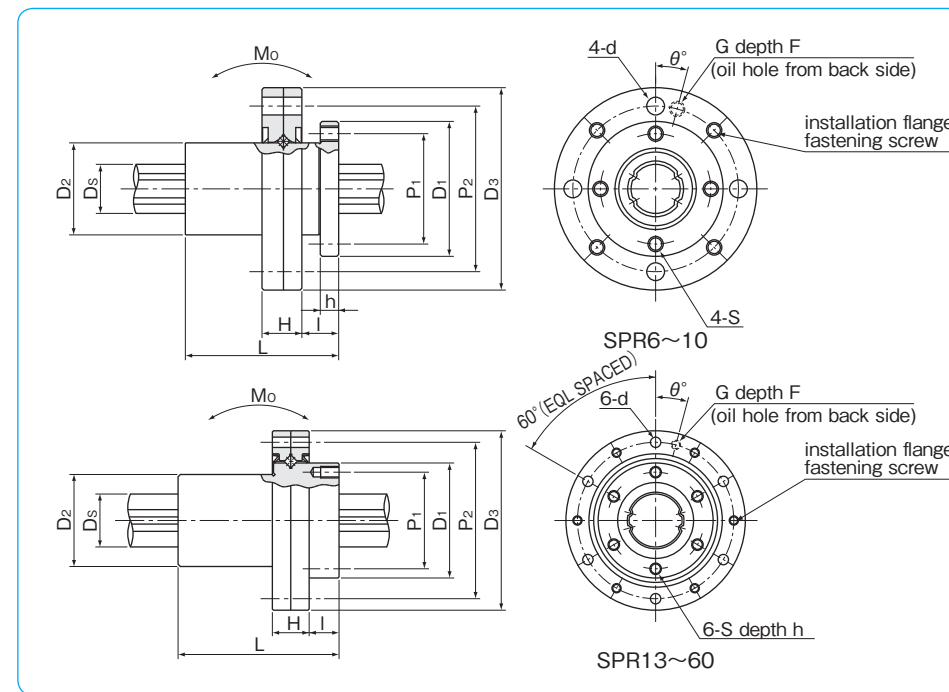

spline shaft D <sub>s</sub> tolerance	ball spline				cross roller bearing			allowable static moment M <sub>0</sub> N · m	mass		size	
	basic torque rating		basic load rating		basic load rating				nut	shaft		
	dynamic C <sub>T</sub> N · m	static C <sub>0T</sub> N · m	dynamic C kN	static C <sub>0</sub> kN	dynamic C <sub>R</sub> kN	static C <sub>0R</sub> kN	※maximum revolutions rpm					kg
6	0/-12	1.5	2.4	1.22	2.28	0.6	0.5	2,940	5.1	0.04	0.21	<b>6</b>
8	0	2.1	3.7	1.45	2.87	1.2	1.10	2,580	7.4	0.05	0.38	<b>8</b>
10	-15	4.4	8.2	2.73	5.07	2.4	2.45	2,060	18.0	0.09	0.60	<b>10</b>
13	0	21	39.2	2.67	4.89	2.9	3.70	1,350	13.7	0.17	1.0	<b>13</b>
16	-18	60	110	6.12	11.2	5.6	6.70	1,080	46	0.33	1.5	<b>16</b>
20	0	105	194	8.9	16.3	6.55	8.79	890	110	0.57	2.4	<b>20A</b>
25	-21	189	346	12.8	23.4	9.63	12.7	700	171	0.81	3.7	<b>25A</b>
30	0	307	439	18.6	23.2	11.8	17.1	640	181	1.19	5.38	<b>30A</b>
40	0	674	934	30.8	37.5	23.0	32.3	510	358	2.25	9.55	<b>40A</b>
50	-25	1,290	2,950	40.3	64.9	27.8	44.0	430	690	3.57	15.0	<b>50A</b>
60	0/-30	1,570	2,620	47.7	79.5	29.0	48.8	370	881	5.03	21.6	<b>60A</b>
18.2	0	83	133	7.84	11.3	5.90	7.35	980	63	0.45	2.0	<b>20</b>
23	-21	162	239	12.3	16.1	9.11	11.5	770	104	0.75	3.1	<b>25</b>
28	0	289	412	18.6	23.2	11.8	17.1	640	181	1.25	4.8	<b>30</b>
37.4	0	637	882	30.8	37.5	23.0	32.3	510	358	2.30	8.6	<b>40</b>
47	-25	1,390	3,180	46.1	74.2	27.2	42.1	450	696	3.10	13.1	<b>50</b>
56.5	0/-30	2,100	4,800	58.0	127	26.5	42.6	400	1,300	4.70	19	<b>60</b>

※Maximum revolutions with grease lubrication.

Contact NB for further information in case oil lubrication is required.

1kN≒102kgf 1N · m≒0.102kgf · m

# SPB-KP TYPE

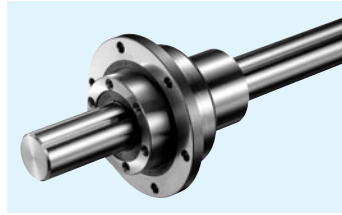

## part number structure

example **SPB 16 KP-2 T1-600-P /CU**

- SPB**: SPB KP type
- 16**: nominal diameter
- KP-2**: number of nuts attached to one shaft
- T1**: preload symbol for linear portion (T1: light, T2: medium)
- 600**: spline shaft total length
- P**: accuracy grade (blank: high, P: precision)
- CU**: with special specification

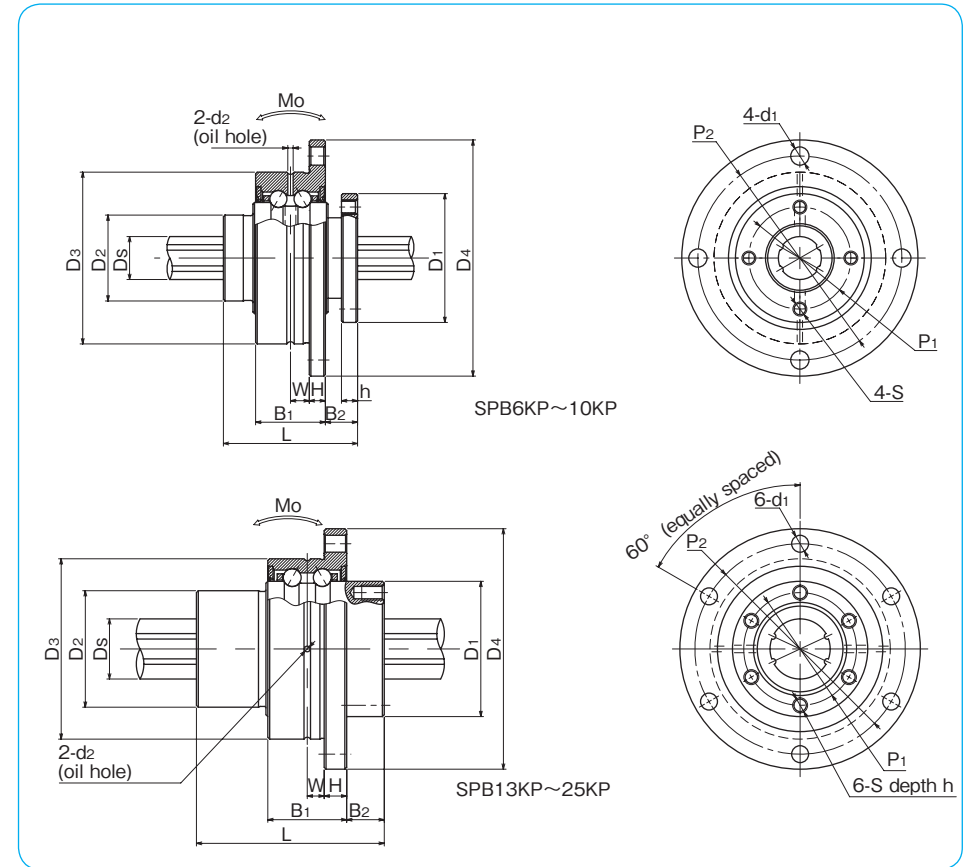

part number	major dimensions							major dimensions of angular contact bearing					
	D <sub>1</sub> h7 mm	D <sub>2</sub> mm	L mm	P <sub>1</sub> P.C.D. mm	S mm	h mm	D <sub>3</sub> g6 mm	D <sub>4</sub> mm	H mm	B <sub>1</sub> mm	B <sub>2</sub> mm	P <sub>2</sub> P.C.D. mm	
<b>SPB 6KP</b>	20	14	25	16	M2	3	28	38	3	13	6	33	
<b>SPB 8KP</b>	24	16	25	19	M2.6	3	32	44	3	13	6	38	
<b>SPB10KP</b>	28	21	33	23	M3	4	36	48	3	15	9	42	
<b>SPB13KP</b>	30	24	36	25	M3	5	44	56	4	18	9	50	
<b>SPB16KP</b>	36	31	50	30	M4	6	48	64	6	21	10	56	
<b>SPB20KP</b>	43.5	35	63	36	M5	8	56	72	6	21	12	64	
<b>SPB25KP</b>	52	42	71	44	M5	8	66	86	7	25	13	75	

d <sub>1</sub> mm	W mm	d <sub>2</sub> mm	D <sub>s</sub> mm	rotary ball spline				angular contact bearings		allowable static moment Mo N·m	mass			
				basic torque rating dynamic C <sub>T</sub> N·m	basic load rating static Co <sub>T</sub> N·m	basic load rating dynamic C kN	basic load rating static Co kN	basic load rating dynamic C <sub>R</sub> kN	basic load rating static Co <sub>R</sub> kN		maximum revolutions rpm	nut kg	shaft kg/m	size
2.4	3.5	1	6	1.5	2.4	1.22	2.28	4.35	2.74	8,100	5.1	0.07	0.21	6
3.4	3.5	1	8	2.1	3.7	1.45	2.87	4.54	3.13	7,000	7.4	0.10	0.38	8
3.4	4.5	1	10	4.4	8.2	2.73	5.07	6.86	4.82	6,200	18.0	0.14	0.60	10
3.4	5	1	13	21	39.2	2.67	4.89	9.45	7.01	5,000	13.7	0.23	1.0	13
4.5	4.5	1.5	16	60	110	6.12	11.2	10.2	8.56	4,200	46	0.37	1.5	16
4.5	4.5	1.5	20	105	194	8.9	16.3	10.9	10.1	3,600	110	0.55	2.4	20
5.5	5.5	1.5	25	189	346	12.8	23.4	13.7	12.9	3,100	171	0.84	3.7	25

※Maximum revolutions with grease lubrication.

# SPB TYPE

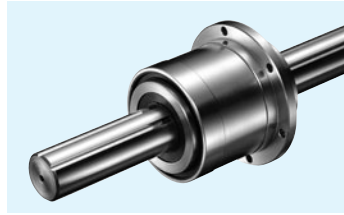

## part number structure

example **SPB 16-2-T1-600-P/CU**

- SPB**: SPB type
- 16**: nominal diameter
- 2**: number of nuts attached to one shaft
- T1**: preload symbol (T1: light, T2: medium)
- 600**: spline shaft total length
- P**: accuracy grade (blank: high, P: precision)
- CU**: with special specification

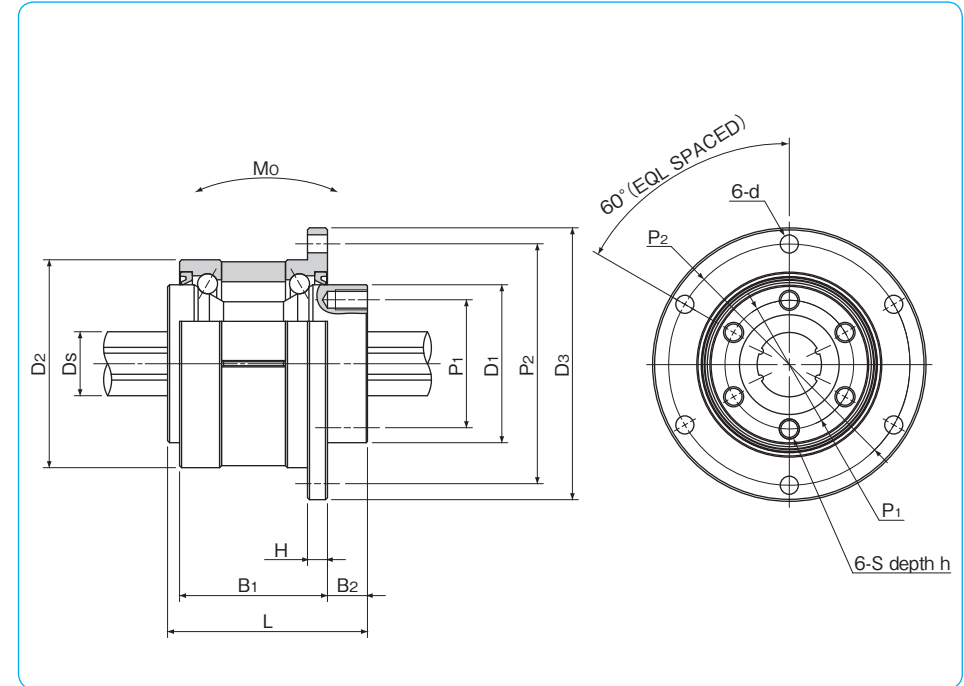

part number	major dimensions						major dimensions of angular contact bearing							
	D <sub>1h7</sub> tolerance	L	P <sub>1</sub> P.C.D.	S	h	D <sub>2</sub> tolerance	D <sub>3</sub>	H	B <sub>1</sub>	B <sub>2</sub>	P <sub>2</sub> P.C.D.	d		
	mm	mm	mm	mm	mm	mm	mm	mm	mm	mm	mm	mm		
<b>SPB16</b>	39.5	0	50	32	M5	8	52	0	68	5	37	10	60	4.5
<b>SPB20</b>	43.5	-25	63	36	M5	8	56	-7	72	6	48	12	64	4.5
<b>SPB25</b>	53	0/-30	71	45	M6	8	62	-7	78	6	55	13	70	4.5

spline shaft		rotary ball spline				angular contact bearings		allowable static moment M <sub>0</sub> N·m	mass		size	
D <sub>s</sub> tolerance	basic torque rating C <sub>T</sub> N·m	static C <sub>0T</sub> N·m	dynamic C kN	static C <sub>0</sub> kN	dynamic C <sub>R</sub> kN	static C <sub>0R</sub> kN	※maximum revolutions rpm		nut kg	shaft kg/m		
mm	μm											
16	0/-18	60	110	6.12	11.2	13.0	12.8	4,000	46	0.54	1.5	<b>16</b>
20	0	105	194	8.9	16.3	17.4	17.2	3,600	110	0.70	2.4	<b>20</b>
25	-21	189	346	12.8	23.4	22.1	22.5	3,200	171	0.91	3.7	<b>25</b>

※Maximum revolutions with grease lubrication. (please contact NB in case of oil lubrication.) 1kN≒102kgf 1N·m≒0.102kgf·m

# STROKE BALL SPLINE

The NB stroke ball spine SPLFS type is a highly accurate linear motion bearing with a limited stroke, to which both radial load and torque can be applied at the same time. It operates with extremely low dynamic friction.

## STRUCTURE AND ADVANTAGES

The NB stroke ball spline consists of a nut and a shaft both with raceway grooves. The flanged spline nut consists of an outer cylinder, a retainer, side-rings, and ball elements. Since the retainer in the nut is equipped with ball pockets, the ball elements do not contact each other, which allows for a smooth linear motion. The stroke is limited since the retainer is a non-circulating type. For normal operation, it is recommended to consider 80% of the maximum stroke shown in the dimension table as an actual stroke length.

### Extremely low Dynamic Friction and Low Noise

The rolling elements are separated by the ball pockets so that they do not contact each other. The stroke length is limited, but extremely low dynamic friction and low noise are realized because the rolling elements do not circulate.

### Compact-Size

With the nut about 20% smaller than those of conventional ball splines, it contributes to space saving.

### All Stainless Steel Type

Since all the components are made of stainless steel, this stroke ball spline has an excellent corrosion resistance and heat resistance (operating temperature: -20 to 140°C). It is ideal for clean room or vacuum applications.

### Lubrication

A lubricant groove and two lubrication holes are provided on the outer surface of the nut, which allows for an easy designing of lubricant replenishment.

Figure B-41 Structure of SPLFS type

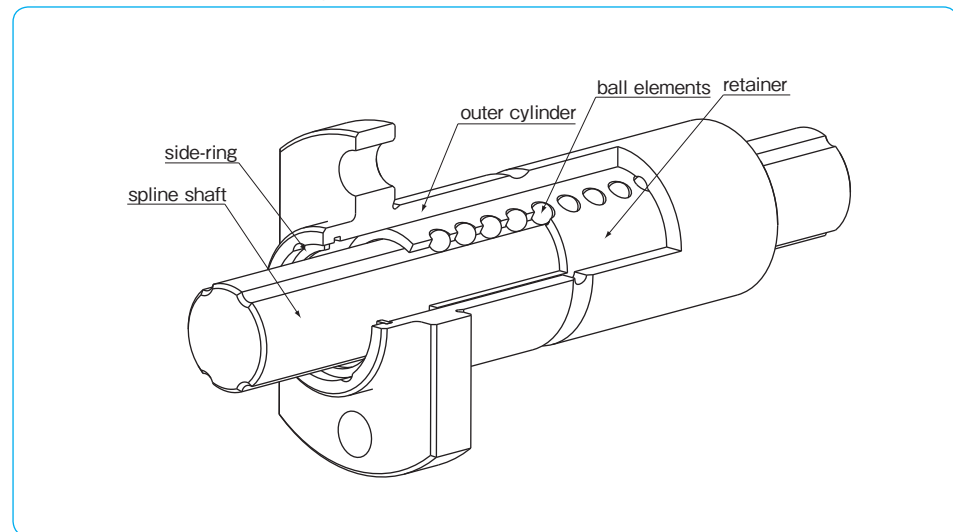

## ACCURACY

The accuracy of the NB stroke ball spline is measured at the points shown in Figure B-42.

Figure B-42 Accuracy Measurement Points

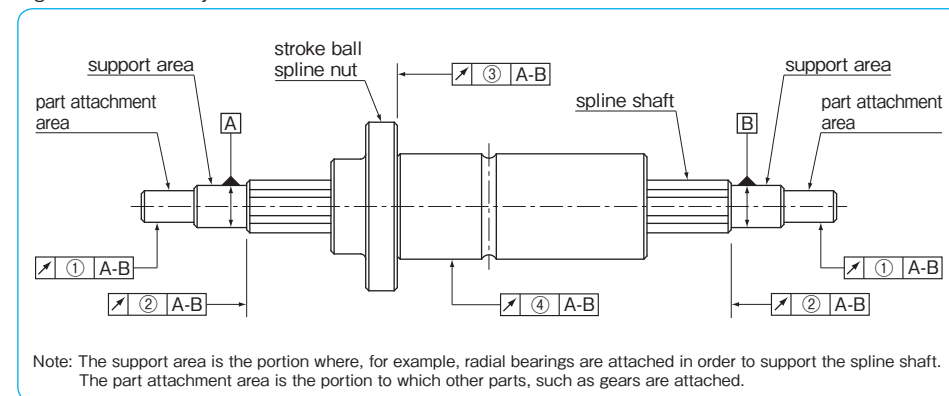

### Tolerance of Spline Shaft Groove Torsion (Max.)

The groove torsion is indicated per 100mm, arbitrarily set as the effective length of the spline shaft section.

Table B-31 Tolerance of Spline Shaft Groove Torsion (Max.)

tolerance
13 μm/100mm

Table B-32 Tolerance Relative to Spline Support Area (Max.)

unit: μm

part number	① radial runout of part attachment area	② radial runout of the end of the spline shaft section	③ radial runout of the flange
SPLFS 6	14	9	11
SPLFS 8	14	9	11
SPLFS10	17	9	13
SPLFS13	19	11	13
SPLFS16	19	11	13

Table B-33 ④Radial Runout of Outer Surface of Spline Nut Relative to Spline Support Area (Max.)

unit: μm

spline shaft total length (mm)		size		
greater than	or less	6, 8	10	13, 16
—	200	46	36	34
200	315	89	54	45
315	400	126*	68	53
400	500	163*	82	62
500	630	—	102	75
630	800	—	—	92
800	1,000	—	—	115
1,000	1,250	—	—	153
1,250	1,500	—	—	256

\* SPLFS6 maximum shaft length: 400 mm



**PRELOAD AND CLEARANCE**

Preload and clearance are expressed in terms of clearance in the rotational direction. For the SPLFS type, only the standard preload is available as shown in Table B-34. Please contact NB if a special preload is required.

Table B-34 Preload and Clearance unit:  $\mu\text{m}$

part number	standard
SPLFS 6	-4~0
SPLFS 8	-4~0
SPLFS10	-4~0
SPLFS13	-4~0
SPLFS16	-4~0

**COMPARISON OF DYNAMIC FRICTIONAL RESISTANCE**

Figure B-43 Comparison of Dynamic Frictional Resistance

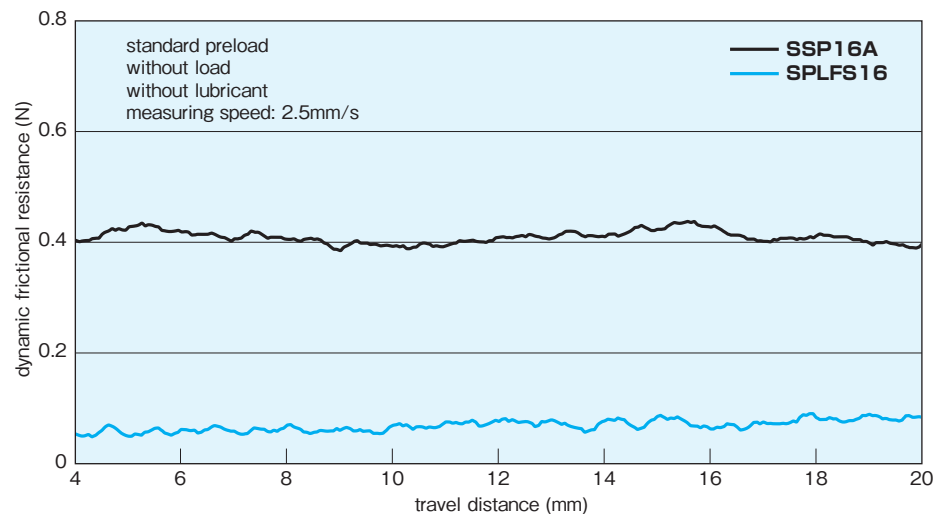

**NUT ORIENTATION**

Unless otherwise specified, the orientation of two nuts NB stroke ball spline is shown in Figure B-44. In other cases please specify the orientation of nut(s) with shaft.

Figure B-44 Nut Orientation and NB mark

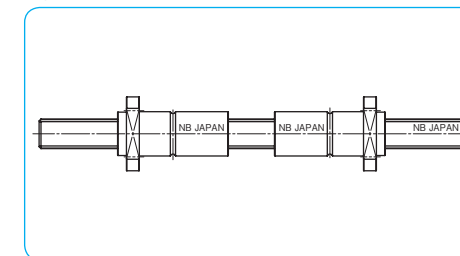

**USE AND HANDLING PRECAUTIONS**

**A Set of Spline Nut and Spline Shaft**

The ball spline's accuracy and preload is guaranteed when spline nut and shaft are aligned as shown in Figure B-45. Please make sure to align the NB marks when reinserting the shaft.

At this time, both NB marks on the nut and shaft should be aligned in the same direction as when delivered.

When inserting the spline shaft into the spline nut, ensure that the ball elements do not drop out. This is done by aligning the raceway grooves of the shaft with the rows of ball elements and the seal lip of the nut. Then, carefully insert the spline shaft through the spline nut. In case that the nut is preloaded, please exercise additional care. And also, do not disassemble the spline nut.

**Dust Prevention**

Since the stroke ball spline is designed and manufactured for operation with an extremely low dynamic frictional resistance, seals that increase frictional resistance are not equipped as a standard feature. Please contact NB for a special requirement of seals. For use under harsh conditions, the stroke ball spline should be protected using bellows and protective covers.

**Maximum Stroke**

The maximum stroke in the dimension table is the stroke limit.

**Retainer Slippage**

If the stroke ball spline is used at a high speed or with a vertical shaft, or under an asymmetric load or oscillation, a retainer slippage may occur. For general operation, it is recommended to consider 80% of the maximum stroke length shown in the dimension table as the stroke length.

To prevent the retainer slippage, it is recommended to conduct a full-stroke movement of the nut whenever necessary in order for the retainer to be relocated to the center.

Figure B-45

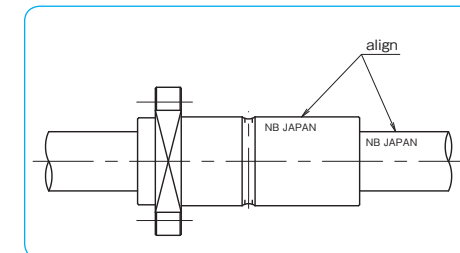

# SPLFS TYPE

— Two Side Cut Flange Type —

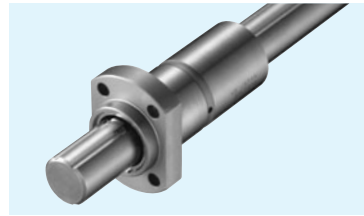

## part number structure

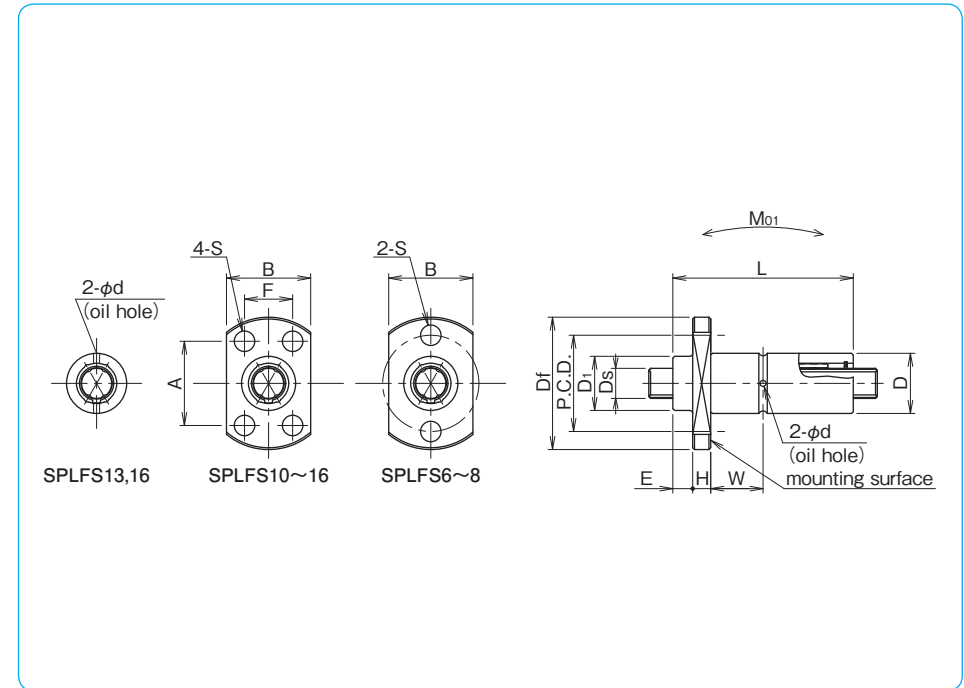
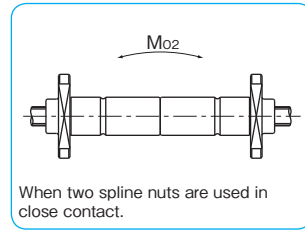
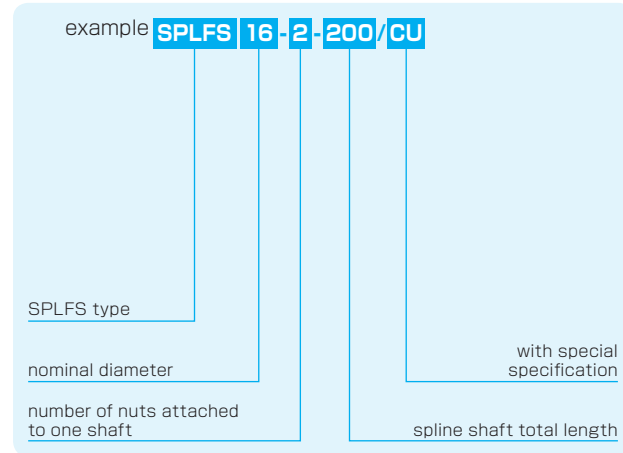

part number	maximum stroke		major dimensions										
	mm	mm	D tolerance μm	D <sub>1</sub> mm	L tolerance mm	E mm	D <sub>f</sub> mm	H mm	B mm	P.C.D. mm	A mm	F mm	
<b>SPLFS 6</b>	22	11	0	10	40	-0.2	3.3	23	4	14	17	—	—
<b>SPLFS 8</b>	20	13		12.5	40		3.3	25.5	4	16	19.5	—	—
<b>SPLFS 10</b>	28	16	-8	15.5	50	3.3	28.5	5	20	—	18	13	
<b>SPLFS 13</b>	24	20	0	19.5	50	4.8	36	5	25	—	22	17	
<b>SPLFS 16</b>	26	24	-9	23.5	60	4.8	40	7	29	—	25	19	

S	W	d	D <sub>s</sub> tolerance μm	basic torque rating		basic load rating		allowable static moment		mass		size	
				dynamic C <sub>T</sub> N·m	static C <sub>0T</sub> N·m	dynamic C kN	static C <sub>0</sub> kN	M <sub>01</sub> N·m	M <sub>02</sub> N·m	nut g	shaft kg/m		
3.4	12.7	1.2	6	0/-12	2.3	3.8	1.8	3.0	11.2	45	21.5	0.21	<b>6</b>
3.4	12.7	1.2	8	0	3.3	5.5	2.02	3.37	13.1	52	27.0	0.38	<b>8</b>
3.4	16.7	1.5	10	-15	6.5	10.9	3.21	5.35	25.6	102	47.7	0.6	<b>10</b>
3.4	15.2	1.5	13	0	27.6	50.7	4.15	7.6	38.8	155	75.3	1.0	<b>13</b>
4.5	18.2	2.0	16	-18	62.8	115	7.66	14	88.3	353	123.5	1.5	<b>16</b>

1kN≐102kgf 1N·m≐0.102kgf·m

# BALL SCREW SPLINE

## STRUCTURE AND ADVANTAGES

The NB Ball Screw Spline consists of a highly accurate and highly rigid Ball Screw nut and Ball Spline nut attached to the ball screw spline shaft which has a screw groove and spline grooves.

SPBR type has a Rotary Ball Screw nut and Rotary Ball Spline nut.

Rotary Ball Screw nut is an integration of ball screw nut and angular contact bearings.

Rotary Ball Spline nut is an integration of ball spline nut and angular contact bearings.

SPBF type has a Rotary Ball Screw nut and a Ball Spline nut.

A single axis of the NB Ball Screw Spline can provide positioning, linear and rotary motion as well as combined spiral motion.

The typical applications are SCARA robot, assembly machine, loader, etc.

Figure B-46 Structure of SPBR type, SPBF type

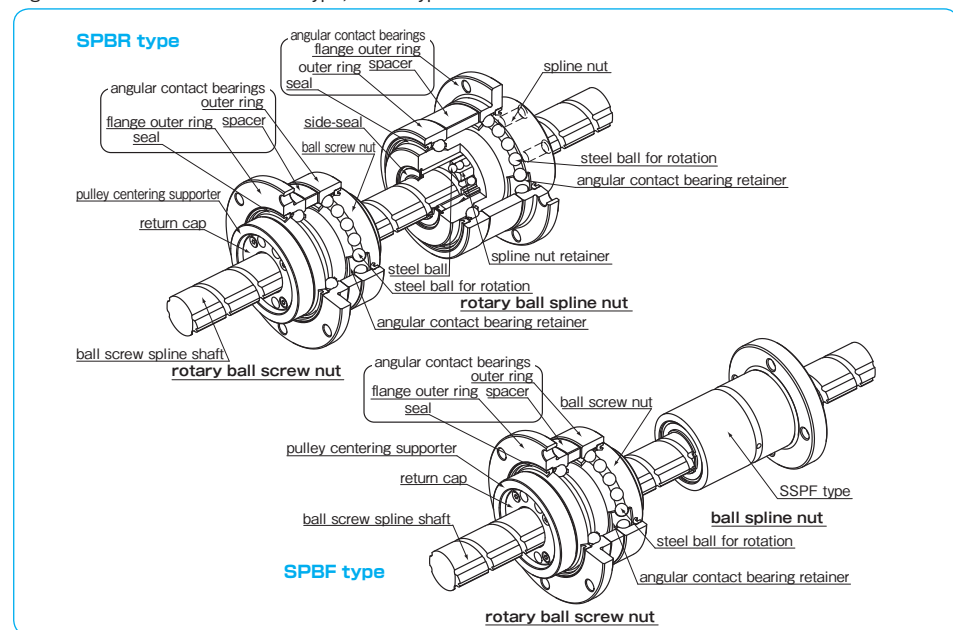

## PRELOAD

The preload is properly adjusted for the ball screw nut, spline nut, and angular contact bearings. Please contact NB for preload specification.

## USE AND HANDLING PRECAUTIONS

- Please do not adjust the spacer. The spacer is adjusted to provide a proper spacing for the best preload condition.
- Please do not remove the Rotary Ball Screw nut from the shaft. There is no ball-retainer in the Rotary Ball Screw nut.
- Please use the pulley centering supporter when attaching the pulley to the return-cap.

## ACCURACY

The NB Ball Screw Spline is measured for accuracy at the points shown in Figure B-47.

Figure B-47 Accuracy Measurement Points

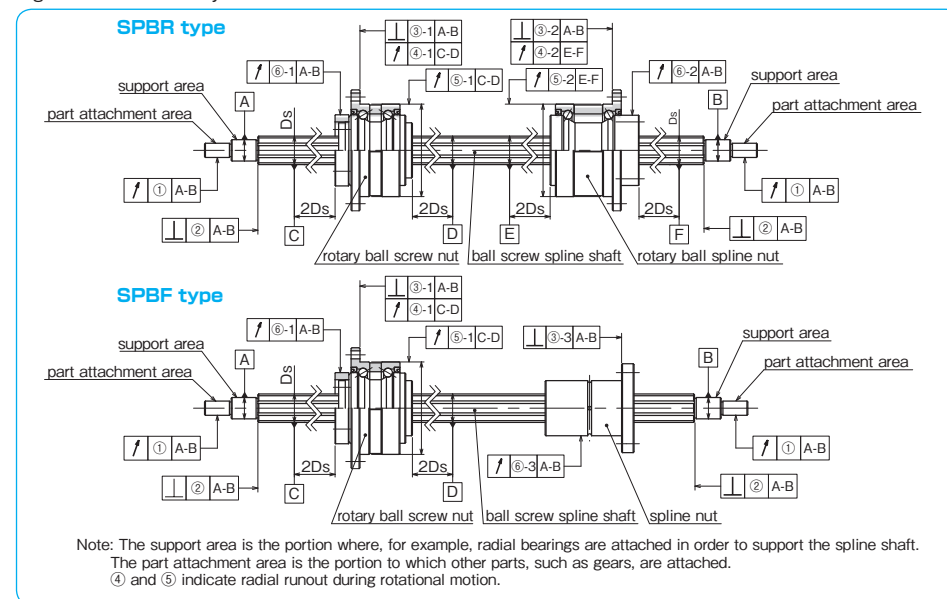

Table B-35 Tolerance of Spline Shaft Groove Torsion (Max.)

tolerance
13μm/100mm

The groove torsion is indicated per 100mm, arbitrarily set within the effective length of the spline shaft section.

Table B-36 Grade of Ball Screw Groove

tolerance
C5

Applied to lead angle accuracy only

Table B-37 Tolerance Relative to Spline Support Area (Max.)

unit: μm

part number	① radial runout of part attachment area	② perpendicularity of the end of the spline shaft section (when grinding is requested on the drawing)	③ perpendicularity of the flange		
			③-1	③-2	③-3
SPBR16,SPBF16	19	11	16	18	13
SPBR20,SPBF20					
SPBR25,SPBF25	22	13	18	21	16

Table B-38 Radial Runout of Outer Surface of Rotary Spline Nut Relative to Spline Shaft Area (Max.) unit: μm

part number	④ radial runout of flange mounting side		⑤ radial runout of outer ring	
	④-1	④-2	⑤-1	⑤-2
SPBR16	8	8	9	9
SPBR20			10	10
SPBR25				

Table B-39 Radial Runout of Spline Nut Relative to Spline Support Area (Max.) unit: μm

ball screw spline shaft total length (mm)	part number:SPBR,SPBF				
	⑥-1		⑥-2,-3		
greater than or less	16	20,25	16	20,25	
—	200	40	35	18	18
200	315	45	40	25	21
315	400	55	45	31	25
400	500	60	50	38	29
500	630	75	60	46	34
630	800	90	70	58	42
800	1,000	120	85	75	52

**SPBR TYPE MOTION PATTERN**

One set of SPBR type can handle linear, rotational, and spiral motion.

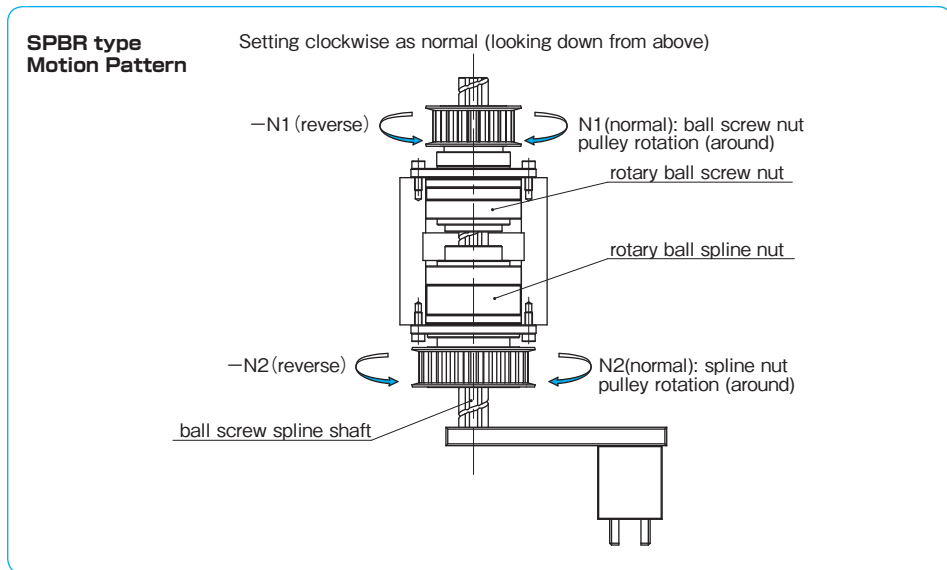

motion	input		motion direction	output		
	ball screw nut	spline nut		travel distance (linear direction)	revolution (rotational direction)	
	N <sub>1</sub> (normal)	0	①	L=N <sub>1</sub> ·R (up)	0	
	-N <sub>1</sub> (reverse)	0	②	L=-N <sub>1</sub> ·R (down)	0	
	N <sub>1</sub> =N <sub>2</sub> (normal)		①	0	N <sub>2</sub> (normal)	
	-N <sub>1</sub> =-N <sub>2</sub> (reverse)		②	0	-N <sub>2</sub> (reverse)	
	0	N <sub>2</sub> (normal)	①	L=N <sub>2</sub> ·R (down)	N <sub>2</sub> (normal)	
	0	-N <sub>2</sub> (reverse)	②	L=-N <sub>2</sub> ·R (up)	-N <sub>2</sub> (reverse)	
	N <sub>1</sub> (normal)	N <sub>2</sub> (normal)	①	L=(N <sub>2</sub> - (±N <sub>1</sub> ))·R	in case of N <sub>2</sub> - (±N <sub>1</sub> )>0 (down)	N <sub>2</sub> (normal)
			④		in case of N <sub>2</sub> - (±N <sub>1</sub> )<0 (up)	
-N <sub>1</sub> (reverse)	-N <sub>2</sub> (reverse)	③	L=(-N <sub>2</sub> - (±N <sub>1</sub> ))·R	in case of -N <sub>2</sub> - (±N <sub>1</sub> )>0 (down)	-N <sub>2</sub> (reverse)	
		②		in case of -N <sub>2</sub> - (±N <sub>1</sub> )<0 (up)		

L : travel distance [mm] R : ball screw lead [mm] N<sub>1</sub> : ball screw nut pulley rotation (around) N<sub>2</sub> : ball spline nut pulley rotation (around)

**SPBF TYPE MOTION PATTERN**

SPBF type can handle linear motion.

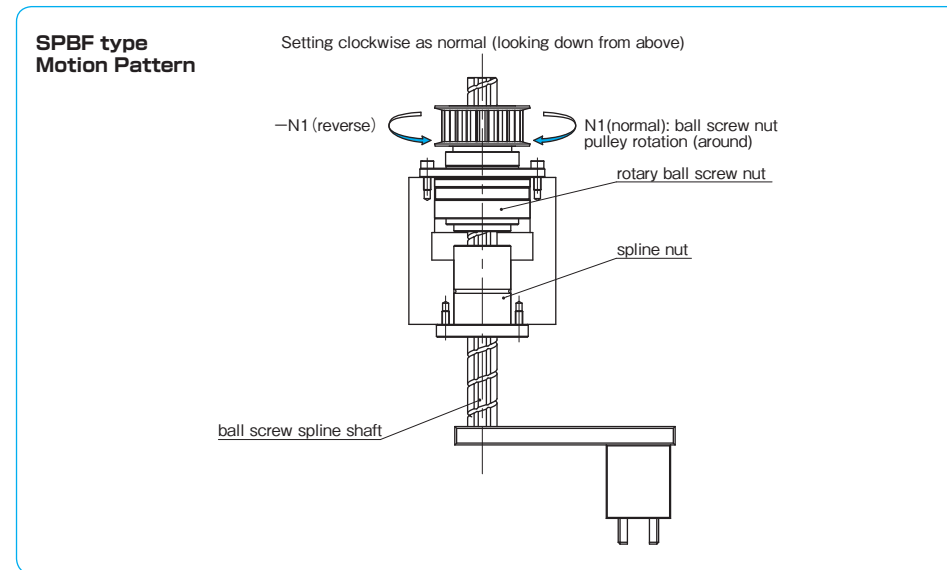

motion	input		motion direction	output	
	ball screw nut	spline nut		travel distance (linear direction)	revolution (rotational direction)
	N <sub>1</sub> (normal)	0	①	L=N <sub>1</sub> ·R (up)	0
	-N <sub>1</sub> (reverse)	0	②	L=-N <sub>1</sub> ·R (down)	0

L : travel distance [mm] R : ball screw lead [mm] N<sub>1</sub> : ball screw nut pulley rotation (around)

**STANDARD AND MAXIMUM LENGTH**

Standard and maximum length of NB ball screw spline shaft are shown in Table B-40.

Table B-40 Standard and Maximum Length of SPBR Type unit : mm

size	standard length			maximum length
	300	500	1,000	
16	300	500	1,000	1,000
20	300	500	1,000	
25	300	500	1,000	

· Please contact NB for shaft lengths exceeding maximum length.

# SPBR TYPE

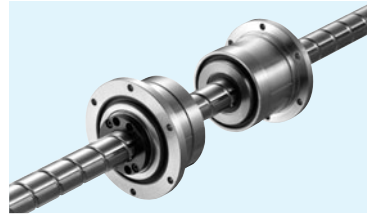

## part number structure

example **SPBR 16 - 300 / CU**

SPBR type

with special specification

nominal diameter

ball screw spline shaft total length

Note: retainer material is resin.

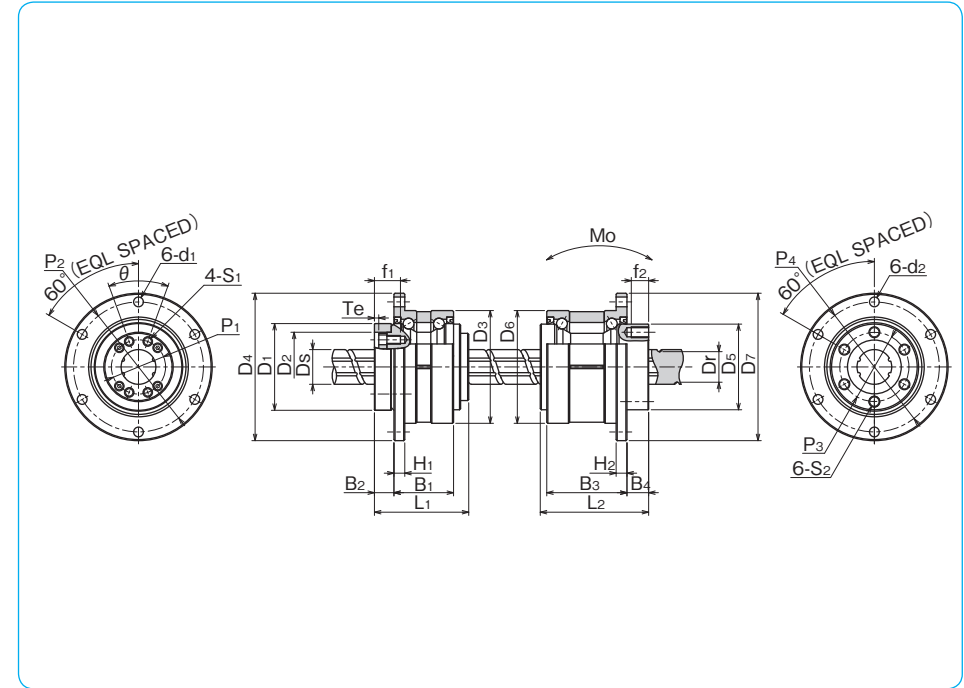

## ROTARY BALL SCREW NUT

part number	major dimensions										major dimensions of angular contact bearings					
	D <sub>1</sub> h7	D <sub>2</sub> H7	L <sub>1</sub>	P <sub>1</sub>	θ	S <sub>1</sub>	f <sub>1</sub>	T <sub>e</sub>	D <sub>3</sub>	D <sub>4</sub>	H <sub>1</sub>	B <sub>1</sub>	B <sub>2</sub>	P <sub>2</sub>	d <sub>1</sub>	
	mm	mm	mm	P.C.D.	°	mm	mm	mm	mm	mm	mm	mm	mm	P.C.D.	mm	
<b>SPBR16</b>	40	32		25	40°	M4	12	2	52	68	5	27.5	9	60	4.5	
<b>SPBR20</b>	50	39		31	40°	M5	16	2	62	78	6	34	11	70	4.5	
<b>SPBR25</b>	58	47		38	40°	M6	19	3	72	92	8	43	12.5	81	5.5	

ball screw spline shaft D <sub>s</sub>	lead	root diameter D <sub>r</sub>	ball screw basic load rating		angular contact bearings basic load rating		moment of inertia for the nut	moment of inertia for the ball screw shaft	mass		ball screw nut maximum revolutions based on D <sub>m</sub> -N rpm	size	
			dynamic C <sub>a</sub>	static C <sub>oa</sub>	dynamic C <sub>R</sub>	static C <sub>oR</sub>			nut	shaft			
mm	mm	mm	kN	kN	kN	kN	kg·cm <sup>2</sup>	kg·cm <sup>2</sup> /mm	kg	kg/m	rpm		
16	16	13.4	4.62	8.59	11.1	22.2	4,000	0.60	4.43×10 <sup>-4</sup>	0.45	1.47	4,179	16
20	20	17.2	5.77	12.2	14.4	30.5	3,200	1.75	1.12×10 <sup>-3</sup>	0.76	2.33	3,414	20
25	25	21.9	8.62	19.2	18.2	39.8	2,800	3.86	2.74×10 <sup>-3</sup>	1.26	3.65	2,692	25

## ROTARY BALL SPLINE NUT

part number	major dimensions						major dimensions of angular contact bearings					
	D <sub>5</sub> h7	L <sub>2</sub>	P <sub>3</sub>	S <sub>2</sub>	f <sub>2</sub>	D <sub>6</sub>	D <sub>7</sub>	H <sub>2</sub>	B <sub>3</sub>	B <sub>4</sub>	P <sub>4</sub>	d <sub>2</sub>
	mm	mm	P.C.D.	mm	mm	mm	mm	mm	mm	mm	P.C.D.	mm
<b>SPBR16</b>	39.5	50	32	M5	8	52	68	5	37	10	60	4.5
<b>SPBR20</b>	43.5	63	36	M5	8	56	72	6	48	12	64	4.5
<b>SPBR25</b>	53	71	45	M6	8	62	78	6	55	13	70	4.5

ball spline				angular contact bearings			allowable static moment M <sub>o</sub>	moment of inertia	mass nut
basic torque rating dynamic C <sub>T</sub>	static C <sub>oT</sub>	basic load rating dynamic C	static C <sub>o</sub>	basic load rating dynamic C <sub>R</sub>	static C <sub>oR</sub>	maximum revolutions			
N·m	N·m	kN	kN	kN	kN	rpm	N·m	kg·cm <sup>2</sup>	kg
60	110	6.12	11.2	13.0	12.8	4,000	46	0.63	0.54
105	194	8.9	16.3	17.4	17.2	3,600	110	1.10	0.70
189	346	12.8	23.4	22.1	22.5	3,200	171	2.14	0.92

\*Please select the smallest maximum revolutions (rpm) in case that more than one portion rotate at the same time.

※Maximum revolutions with grease lubrication.

\*Moment of inertia is calculated excluding the angular contact bearings.

# SPBF TYPE

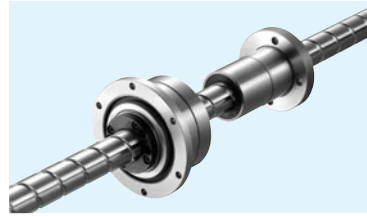

## part number structure

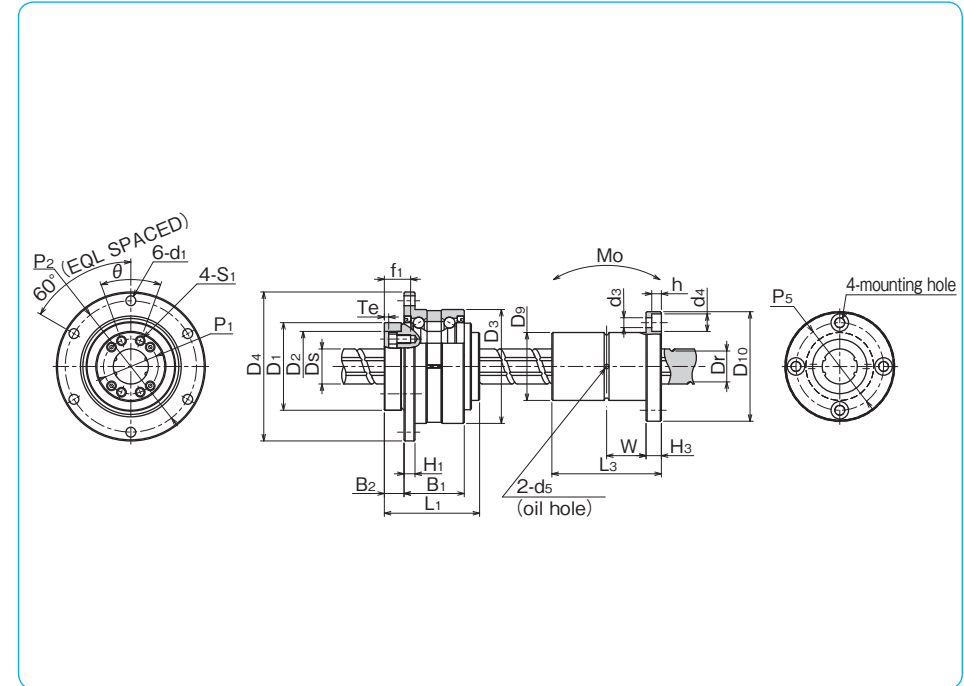
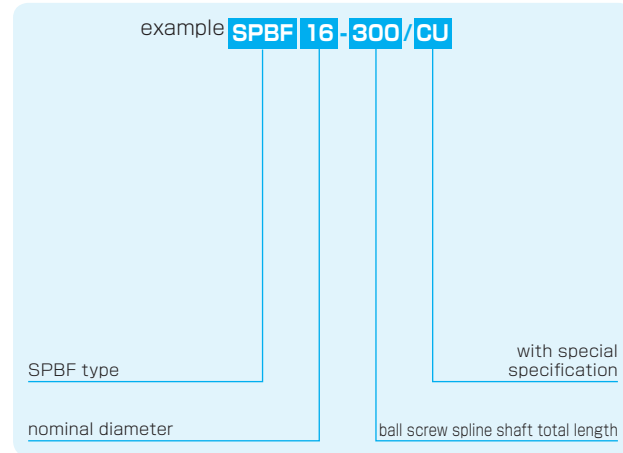

## ROTARY BALL SCREW NUT

part number	major dimensions										major dimensions of angular contact bearings					
	D <sub>1</sub> h7	D <sub>2</sub> H7	L <sub>1</sub>	P <sub>1</sub> P.C.D.	θ	S <sub>1</sub>	f <sub>1</sub>	T <sub>e</sub>	D <sub>3</sub> tolerance	D <sub>4</sub>	H <sub>1</sub>	B <sub>1</sub>	B <sub>2</sub>	P <sub>2</sub> P.C.D.	d <sub>1</sub>	
	mm	μm	mm	mm	°	mm	mm	mm	μm	mm	mm	mm	mm	mm	mm	
<b>SPBF16</b>	40	0	32	43.5	25	40°	M4	12	2	52	68	5	27.5	9	60	4.5
<b>SPBF20</b>	50	-25	39	54	31	40°	M5	16	2	62	78	6	34	11	70	4.5
<b>SPBF25</b>	58	0/-30	47	65	38	40°	M6	19	3	72	92	8	43	12.5	81	5.5

ball screw spline shaft D <sub>s</sub>	lead	root diameter D <sub>r</sub>	ball screw basic load rating		angular contact bearings basic load rating		bearings * maximum revolutions	moment of inertia for the nut	moment of inertia for the ball screw shaft	mass		ball screw nut maximum revolutions based on D <sub>m</sub> ·N	size
			dynamic C <sub>a</sub>	static C <sub>oa</sub>	dynamic C <sub>aR</sub>	static C <sub>oaR</sub>				nut	shaft		
mm	mm	mm	kN	kN	kN	kN	rpm	kg·cm <sup>2</sup>	kg·cm <sup>2</sup> /mm	kg	kg/m	rpm	
16	16	13.4	4.62	8.59	11.1	22.2	4,000	0.60	4.43×10 <sup>-4</sup>	0.45	1.47	4,179	16
20	20	17.2	5.77	12.2	14.4	30.5	3,200	1.75	1.12×10 <sup>-3</sup>	0.76	2.33	3,414	20
25	25	21.9	8.62	19.2	18.2	39.8	2,800	3.86	2.74×10 <sup>-3</sup>	1.26	3.65	2,692	25

## BALL SPLINE NUT

part number	major dimensions							
	D <sub>9</sub> h6	L <sub>3</sub>	D <sub>10</sub>	H <sub>3</sub>	P <sub>5</sub> P.C.D.	d <sub>3</sub> ×d <sub>4</sub> ×h		
	mm	mm	mm	mm	mm	mm	mm	
<b>SPBF16</b>	31	50	50	7	40	4.5×8×4.4		
<b>SPBF20</b>	35	63	58	9	45	5.5×9.5×5.4		
<b>SPBF25</b>	42	71	65	9	52	5.5×9.5×5.4		

W	d <sub>5</sub>	basic torque rating		basic load rating		allowable static moment M <sub>o</sub>	moment of inertia	mass nut
		dynamic C <sub>T</sub>	static C <sub>oT</sub>	dynamic C	static C <sub>o</sub>			
mm	mm	N·m	N·m	kN	kN	N·m	kg·cm <sup>2</sup>	kg
18	2	60	110	6.12	11.2	46	0.52	0.2
22.5	2	105	194	8.9	16.3	110	1.11	0.33
26.5	3	189	346	12.8	23.4	171	2.01	0.45

•Please select the smallest maximum revolutions (rpm) in case that more than one portion rotate at the same time.  
 ※Maximum revolutions with grease lubrication.  
 •Moment of inertia is calculated excluding the angular contact bearings.