

SPB TYPE

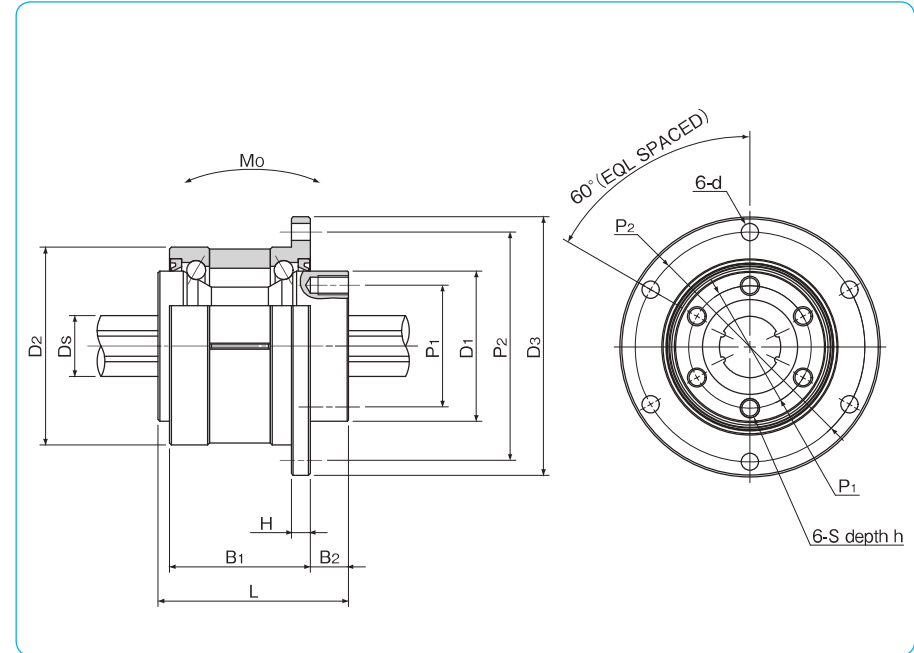

part number structure

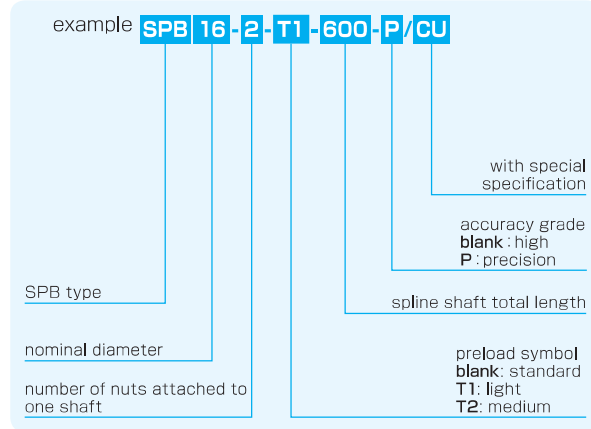

part number	major dimensions						major dimensions of angular contact bearing							
	D _{1h7}	L	P ₁	S	h	D ₂	D ₃	H	B ₁	B ₂	P ₂	d		
	mm	mm	mm	mm	mm	mm	mm	mm	mm	mm	mm	mm		
SPB16	39.5	0	50	32	M5	8	52	0	68	5	37	10	60	4.5
SPB20	43.5	-25	63	36	M5	8	56	-7	72	6	48	12	64	4.5
SPB25	53	0/-30	71	45	M6	8	62		78	6	55	13	70	4.5

spline shaft D _s tolerance	rotary ball spline				angular contact bearings			allowable static moment M ₀ N·m	mass		size
	basic torque rating dynamic C _T N·m	static Co _T N·m	basic load rating dynamic C kN	static Co kN	basic load rating dynamic C _R kN	static Co _R kN	※maximum revolutions rpm		nut kg	shaft kg/m	
16 0/-18	60	110	6.12	11.2	13.0	12.8	4,000	46	0.54	1.5	16
20 0	105	194	8.9	16.3	17.4	17.2	3,600	110	0.70	2.4	20
25 -21	189	346	12.8	23.4	22.1	22.5	3,200	171	0.91	3.7	25

※Maximum revolutions with grease lubrication.(please contact NB in case of oil lubrication.) 1kN≐102kgf 1N·m≐0.102kgf·m

ROTARY BALL SPLINE