

**Spindelanbauteile**  
**Screw attachments**

**Hochleistungsgelenkköpfe High Performance Joint Heads HG**

Der Hochleistungsgelenkkopf HG wird auf das Befestigungsgewinde der Gewindespindel geschraubt und mit einer Kontermutter gesichert. Bei der Ausführung N muss der Gelenkkopf an der Schlüsselflache SW zusätzlich gegen Verdrehen gesichert werden. Für hohe axiale Belastung, wartungsfrei. Auch in rostfreier Ausführung verfügbar. Inkl. Kontermutter nach DIN 439.

The HG heavy-duty rod end is screwed onto the mounting thread of the threaded screw and secured with a lock nut. For version N, the rod end must be additionally secured against rotation at the wrench flat SW. For high axial loads, maintenance-free. Also available in stainless steel. Incl. lock nut according to DIN 439.

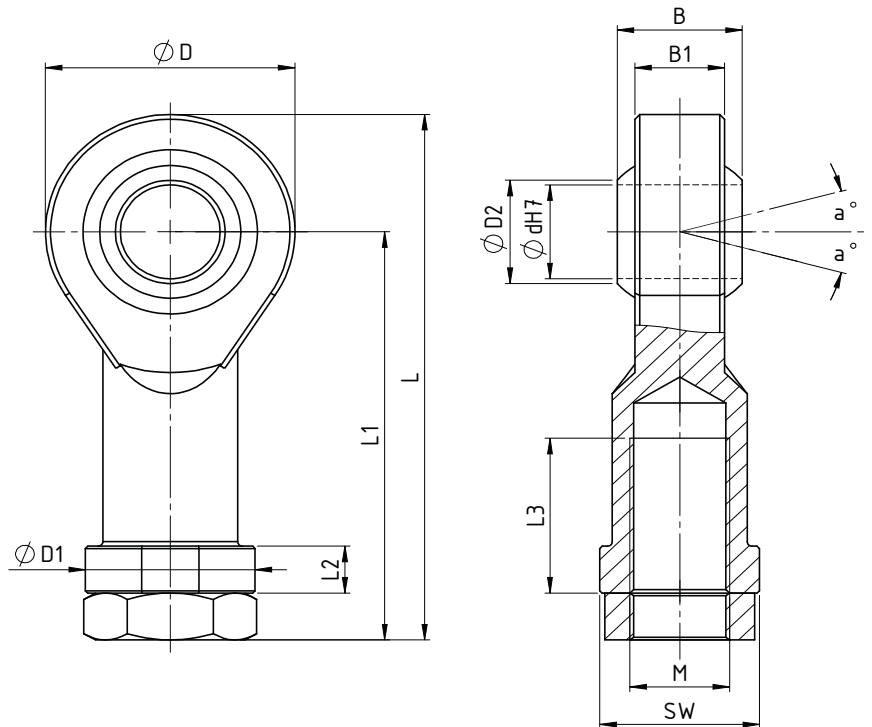
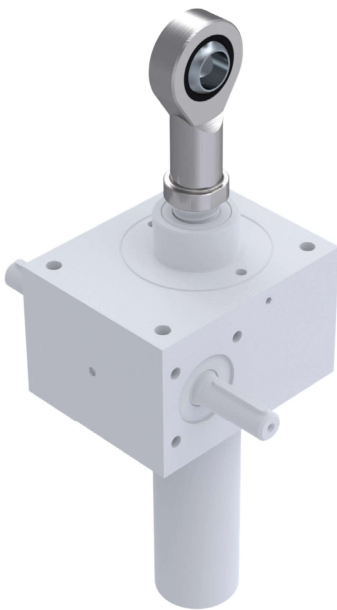

**Technische Daten/Abmessungen Technical data/dimensions**

Maß dimension	Abmessungen dimensions [mm]													Winkel angle (°)	Gewicht weight [kg]
	dH7	M	B	B <sub>1</sub>	D	D <sub>1</sub>	D <sub>2</sub>	L	L <sub>1</sub>	L <sub>2</sub>	L <sub>3</sub>	SW			
HG-M0	10	M10	14	10,5	28	19	12,9	62	48	6,5	20	17	17,65	13	0,076
HG-M1	12	M12	16	12	32	22	15,4	72	56	6,5	22	19	20,6	13	0,115
HG-M2	14	M14	19	13,5	36	25	16,8	82	64	8	25	22	29,4	15	0,17
HG-M3	20	M20x1,5	25	18	50	34	24,3	112	87	10	33	32	49,1	15	0,415
HG-M4	30	M30x2	37	25	70	50	34,8	160	125	15	51	41	99,1	15	1,13
HG-M5	35	M36x2	43	28	80	58	37,7	183	143	17	65	50	125	15	1,6
HG-J1	50	M48x2	60	45	116	78	55,9	242	184	16	65	65	308	14	5,0
HG-J2	70	M56x4	49	42	160	58	92	308	228	20	80	85	630	6	8,4
HG-J3	70	M56x4	49	42	160	98	92	308	228	20	80	85	630	6	8,4

