

Wellenkupplungen RA, RG
Shaft Couplings RA, RG

Die Wellenkupplungen RA bzw. RG gleichen kleinere winkelige, radiale und axiale Wellenverlagerungen aus. Dadurch erhöhen Kupplungen die Lebensdauer von Gewindetribe, Spindelhubgetriebe, Kegelradgetriebe sowie Motoren durch Ihre stoß- und schwingungsdämpfende Wirkung.

Shaft couplings RA and RG compensate for minor angular, radial and axial shaft misalignments. In this way, couplings increase the service life of screw drives, worm gear screw jacks, bevel gearboxes and motors through their shock- and vibration-damping effect.

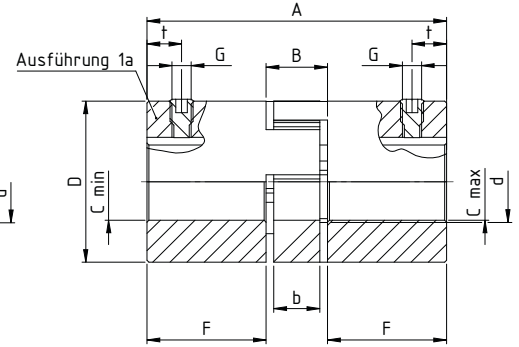
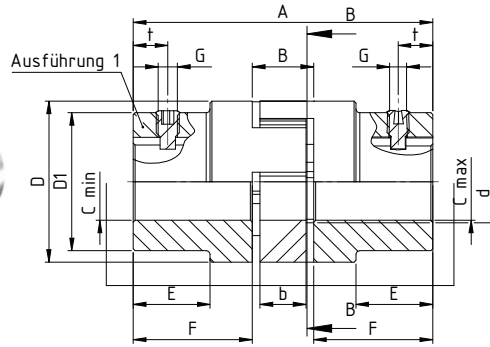

Technische Daten/Abmessungen **Technical data/dimensions**

Baugröße size	Ausführung design	Abmessungen dimensions [mm]											Gewicht weight [kg]	
		A	E	F	B	b	D ₁	D	d	C _{min} ¹⁾	C _{max} ¹⁾	G		t
RA-14	1a	35	-	11	13	10	-	30	10	6	15	M4	5	0,05
RA-19	1	66	20	25	16	12	32	40	18	10	19	M5	10	0,15
RA-19	1a	66	-	25	16	12	-	41	18	19	24	M5	10	0,15
RA-24	1	78	24	30	18	14	40	55	27	14	24	M5	10	0,25
RA-24	1a	78	-	30	18	14	-	56	27	22	28	M5	10	0,35
RA-28	1	90	28	35	20	15	48	65	30	14	28	M6	15	0,40
RA-28	1a	90	-	35	20	15	-	67	30	28	38	M6	15	0,55
RA-38	1a	114	37	45	24	18	66	80	38	16	38	M8	15	0,85
RA-42	1a	126	40	50	26	20	75	95	46	28	42	M8	20	1,2
RA-48	1a	140	45	56	28	21	85	105	51	28	48	M8	20	1,7
RG-55	1	160	52	65	30	22	98	120	60	30	55	M10	20	7,3
RG-55	1a	160	-	65	30	22	-	120	60	30	55	M10	20	8
RG-65	1	185	61	75	35	26	115	135	68	40	65	M10	20	11,0
RG-75	1	210	69	85	40	30	135	160	80	40	75	M10	25	17,9
RG-90	1	245	81	100	45	34	160	200	100	50	90	M12	30	28,5

Größe size	Zahnkranz gear rim [98 Shore A]					Zahnkranz gear rim [92 Shore A]					Zahnkranz GS gear rim GS [98 Shore A]				
	max Winkelverlagerung max. angular displacement	max Axialverlagerung max. axial displacement	Nenn Drehmoment nominal torque	max Drehmoment max. RPM	max. Verdrehwinkel max. twisting angle	max Winkelverlagerung max. angular displacement	max Axialverlagerung max. axial displacement	Nenn Drehmoment nominal torque	max Drehmoment max. RPM	Verdrehwinkel twisting angle	max Winkelverlagerung max. angular displacement	max Axialverlagerung max. axial displacement	Nenn Drehmoment nominal torque	max Drehmoment max. RPM	Dyn. Drehfedersteifigkeit dyn. torsional stiffness
	°	[mm]	T _{kN} [Nm]	T _{Kmax} [Nm]	V _{Kmax} [°]	°	[mm]	T _{kN} [Nm]	T _{Kmax} [Nm]	V _{Kmax} [°]	°	[mm]	T _{kN} [Nm]	T _{Kmax} [Nm]	[Nm/rad]
RA-9	-	-	-	-	-	-	-	-	-	-	0,9	-0,4/+0,8	5	10	155
RA-14	1,2	-0,5/+1	12,5	25	10	1,2	-0,5/+1	7,5	15	10	0,9	-0,5/+1	12,5	25	513
RA-19	1,2	-0,5/+1,2	17	34	5	1,2	-0,5/+1,2	10	20	5	0,9	-0,5/+1,2	17	34	2540
RA-24	0,9	-0,5/+1,4	60	120	5	0,9	-0,5/+1,4	35	70	5	0,9	-0,5/+1,4	60	120	4010
RA-28	0,9	-0,7/+1,5	160	320	5	0,9	-0,7/+1,5	95	190	5	0,9	-0,7/+1,5	160	320	9920
RA-38	1,0	-0,7/+1,8	325	650	5	1,0	-0,7/+1,8	190	380	5	0,9	-0,7/+1,8	325	650	17160
RA-42	1,0	-1/+2	450	900	5	1,0	-1/+2	265	530	5	0,9	-1/+2	450	900	37692
RA-48	1,1	-1/+2,1	525	1050	5	1,1	-1/+2,1	310	620	5	0,9	-1/+2,1	525	1050	45620
RG-55	1,1	-1/+2,2	685	1370	5	1,1	-1/+2,1	410	820	5	0,9	-1/+2,1	685	1370	61550
RG-65	1,2	-1/+2,6	940	1880	5	1,2	-1/+2,6	625	1250	5	0,9	-1/+2,6	940	1880	71660
RG-75	1,2	-1,5/+3	1920	3840	5	1,2	-1,5/+3	1280	2560	5	0,9	-1,5/+3	1920	3840	150450
RG-90	1,2	-1,5/+3,4	3600	7200	5	1,2	-1,5/+3,4	2400	4800	5	0,9	-1,5/+3,4	3600	7200	302900