

perma Lubrication systems for

Food & beverage industry

perma-tec GmbH & Co. KG
Hammelburger Str. 21
97717 EUERDORF
GERMANY

sales@perma-tec.com
www.perma-tec.com



The Expert in Lubrication Solutions

perma



perma Lubrication systems for
Food & beverage industry

In the food & beverage industry, manufacturing processes are precisely synchronised. State-of-the-art automation requires optimal equipment and machine lubrication. perma has a wide range of automated lubrication solutions with suitable lubricants for the food sector.

Lubrication Points

1 Roller bearings

2 Sliding bearings

3 Chains

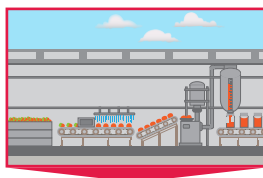

Delivery & storage		1	2	3
→ Transporting & sorting	Conveyor belts, depalletizers, sorting systems	✓	-	✓
→ Cleaning	Drum systems, belt washing systems, peeling machines	✓	✓	-



Final processing		1	2	3
→ Milling, crushing, mixing, pressing	Presses, cutters, cutting machines	✓	✓	-
→ Transporting	Wire mesh, link chain & flat top chain conveyors	✓	-	✓
→ Filling, portioning	Vibrating filling system, filler, capper	✓	-	✓



Packing & shipment		1	2	3
→ Labelling	Labelling machine	✓	-	-
→ Packing	Packaging machine, film wrapping machine, shrink tunnel	✓	-	✓
→ Transporting, palletising	Palletiser, pallet conveyor, chain conveyor	✓	-	✓

Challenges



→ Hard-to-reach and dangerous lubrication points



→ Extreme operating conditions (water, temperature changes and vibrations)



→ High standards for hygiene and cleanliness

Advantages of automatic lubrication

- ✓ Remote installations of lubrication systems **reduce the time that workers have to spend in dangerous areas**
- ✓ Continuous relubrication at short intervals **reduces wear and seals lubrication points against contamination**
- ✓ **Scheduled exchanges** on running equipment **reduce staff- and material costs** and increase economic efficiency
- ✓ Reduces the **amount of lubricant** to the minimum of the necessary quantity and avoid the contamination of the **production process** with lubricants

References



Solutions

Direct mounting on lubrication point: e.g. perma FLEX PLUS

- Easy, quick mounting
- For lubrication points with little vibration / shocks
- For easy-to-access and safe lubrication points

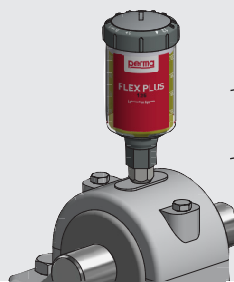

perma FLEX PLUS 125

MOUNTING SET
Direct mounting

Art. No. 101476



Remote mounting to lubrication point: e.g. perma STAR VARIO

- For lubrication points with strong vibration / shocks (isolation of lubrication system)
- When workers' safety is at risk: Mounting in safe areas
- For hard-to-access lubrication points

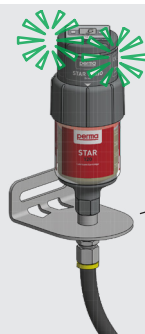

perma STAR VARIO
with LC 120

MOUNTING SET
Remote mounting
with low pressure tube

Art. No. 101482



Would you like more information on perma products?

- Detailed product information in our **perma LUBE BOOK**
- Visit our website **www.perma-tec.com**

perma FLEX / perma FLEX PLUS

The flexible, compact lubrication system for high demands



perma FLEX



II 1G Ex ia IIC T6
II 1D Ex iaD 20 T85°C
I M1 Ex ia I



TIIS

perma FLEX PLUS



I M1 Ex ia I Ma
II 1G Ex ia IIC T6 Ga
II 1D Ex ia IIC T85 °C Da

ANZEx



Flexible use – even on lubrication points with challenging requirements

perma FLEX and perma FLEX PLUS are compact, ready-to-use lubrication systems which are delivered as a complete unit. They can be used in various types of applications at temperatures ranging from $-20\text{ }^{\circ}\text{C}$ to $+60\text{ }^{\circ}\text{C}$ (FLEX PLUS: $+55\text{ }^{\circ}\text{C}$). The discharge period setting is freely adjustable from 1 to 12 months. The required pressure of up to 5 bar is built up using an electronically controlled chemical reaction. The lubrication point is continuously supplied with fresh lubricant throughout the selected discharge period. perma FLEX is available in sizes 60 cm^3 and 125 cm^3 ; perma FLEX PLUS also in 30 cm^3 .

perma

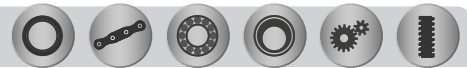

perma FLEX and perma FLEX PLUS comply with IP 68 requirements (ingress of fluids / solids) and operate reliably in extremely dusty and moist ambient conditions. Lubrication can be interrupted if required. The discharge period can be changed even after activation. perma FLEX PLUS is ideal for use in the chemical-, pharma-, and food industry.

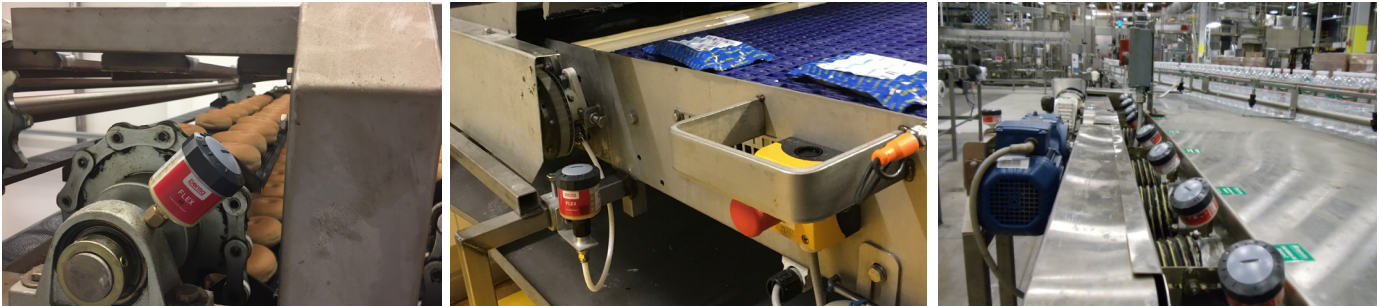

Product characteristics

Benefits



All-in-one system with rotary switch for setting the discharge period:
1, 2, 3 ... 12 months

- System is supplied fully mounted and is ready to use immediately
- Easy setting and activation using rotary switch
- Discharge period can be regulated from 1–12 months in monthly steps

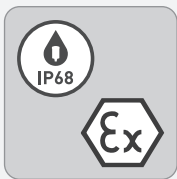

IP 68
Ex-proof certification

- Safe and reliable lubrication in explosive areas
- Can be used in very moist and dusty environments
- Increased workplace safety



perma FLEX PLUS
Drive with gas generating cells and boost function

- Activation of boost function ensures quick lubricant supply

Technical data

Drive

Electrochemical reaction

Discharge period at +20 °C /
perma Multipurpose grease SF01
1, 2, 3 ... 12 months

Lubricant volume

30 cm³ (FLEX PLUS)
60 cm³ or 125 cm³ (FLEX & FLEX PLUS)

Operating temperature

-20 °C to +60 °C / +55 °C (FLEX PLUS)

Pressure build-up

Max. 5 bar

Protection class

IP 68

Standard & special lubricants

Greases up to NLGI 2 / Oils

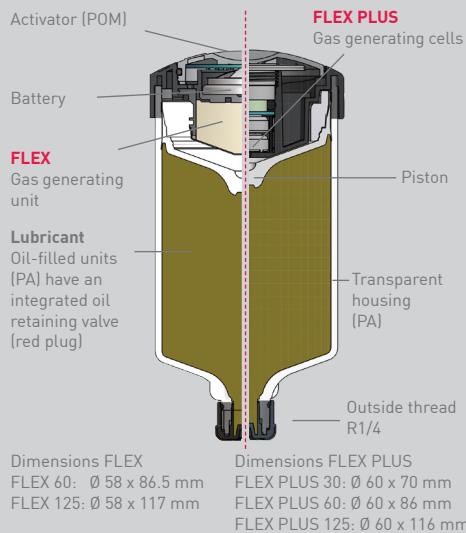

Discharge period setting in months:

Reference values for emptying without counter pressure with lubricant NLGI 2 for perma FLEX 125 / perma FLEX PLUS 125.

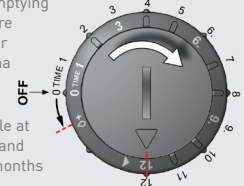

Grease residues possible at temperatures > +40 °C and discharge periods > 6 months

	1	3	6	9	12
at -20 °C	2	5	10	13	15
at 0 °C	1.3	3.8	7.2	11	13
at +20 °C	1	3	6	9	12
at +40 °C	0.8	2.5	5.2	7.5	10
at +60 °C	0.6	2	4	-	-

perma STAR VARIO

High-precision and easy-to-use lubrication system – independent of temperature and counter pressure



Three different sizes for individual lubricant metering

perma STAR VARIO operates fully automatically, independent of temperature and ideal for the constant dispensing of small, adapted lubricant quantities. There for the unit is excellent for the use in peripheral equipment in the food industry. The system consists of an electromechanical drive, an LC with 60, 120 or 250 cm³ of lubricant and a battery pack. The desired discharge period and LC size can easily be selected with the push button and are immediately visible in the LCD. The current operating status is indicated on the LCD and via LED signal lights (red / green) visible all round. The LED signals are recognisable from a distance.

perma

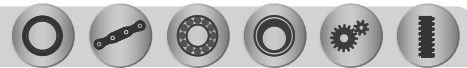

perma STAR VARIO is used for single-point lubrication of roller and sliding bearings, sliding guides, open gears, gear racks, spindles, shaft seals and chains. Due to the precise lubricant metering, perma STAR VARIO is ideal for lubrication of electric motors with specified lubricant quantities. perma STAR VARIO is protected against dust and water jets, subject to correct assembly of the individual parts (IP 65).

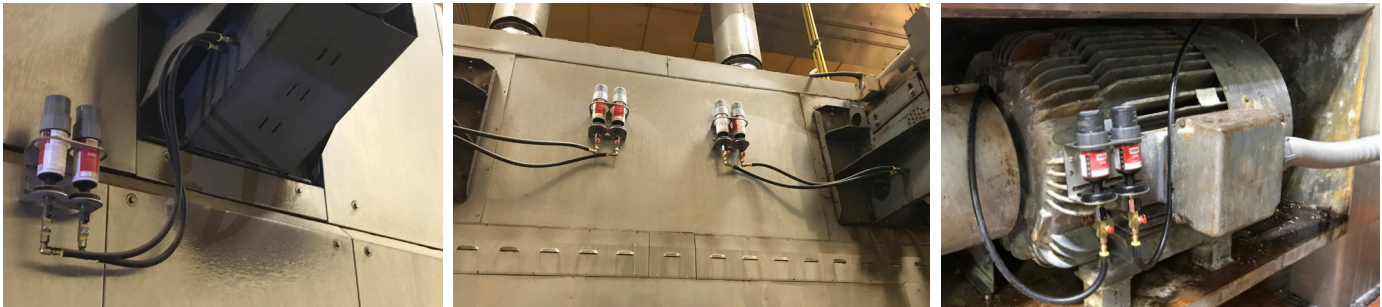

Product characteristics

Benefits



LCD display with push button displays discharge period, LC size and operating status

Setting:
1, 2, 3 ... 12 months and LC size

- Simple and self-explanatory operation
- Precise settings according to requirements prevent lubrication starvation and over-lubrication
- Settings can be changed at any time
- Can be turned off for extended equipment shut downs



Electromechanical, reusable drive with battery pack

LED (red / green) visible all round signals functioning and any errors

- Reliable, precise lubricant discharge independent of temperature and counter pressure
- Reusable STAR VARIO Drive
- Quick function control via LED signals saves time and relieves maintenance workers



Pressure build-up to 6 bar allows remote mounting up to 5 m

Manual additional discharge via button on display (purge)

- Mounting outside of dangerous areas or at easy-to-reach locations increases workplace safety
- Higher equipment availability since LC can be easily exchanged during running operation
- Lubrication point can be purged to clear blockages

Technical data

Drive – reusable
Electromechanical function with Battery pack STAR VARIO

Discharge period
1, 2, 3 ... 12 months

Lubricant volume
60 cm³, 120 cm³ or 250 cm³

Operating temperature
-20 °C to +60 °C

Pressure build-up
6 bar

Protection class

IP 65
Standard & special lubricants
Greases up to NLGI 2 / Oils

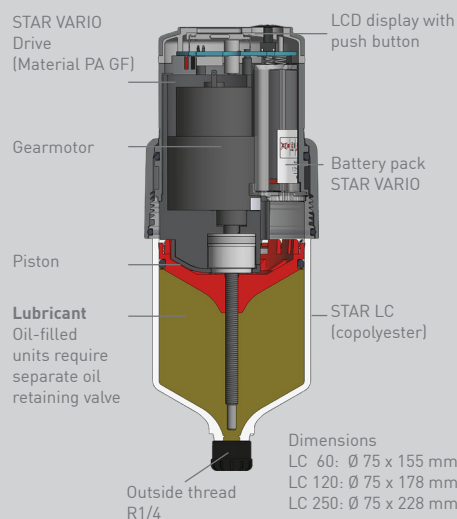

perma STAR CONTROL

TIME and IMPULSE mode combined in a single system



Optimal lubricant metering based on operating hours or lubrication impulse

In contrast to the perma STAR VARIO (with battery pack), the perma STAR CONTROL is supplied with external power via cable. The operating status can be transmitted to a PLC and evaluated. The two integrated operating modes TIME and IMPULSE offer flexible use. In TIME mode, lubricant discharge is based on operating hours. In IMPULSE mode, a precisely defined quantity is dispensed as soon as voltage is supplied.

The perma STAR CONTROL consists of an electromechanical drive and an LC with 60, 120 or 250 cm³ of lubricant. The required mode is set on the drive. Lubrication is precise and temperature-independent at a counter pressure up to 6 bar.

perma



perma STAR CONTROL is used to lubricate roller and sliding bearings, sliding guides, open gears, gear racks, spindles, shaft seals and chains. Due to the precise lubricant metering, perma STAR CONTROL is ideally suited for lubrication of electric motors with specified lubricant quantities. The system is protected against dust and water jets, subject to correct assembly of the individual parts (IP65).



Product characteristics

Benefits



LCD display with push button shows discharge settings, LC size and operating status

Setting:
Mode, LC size, discharge quantity and PIN

- Flexible handling via simple setting of TIME or IMPULSE mode; can be changed at any time
- Fast, simple control of settings, remaining impulses or operating hours until exchange
- Freely selectable PIN protects against possible tampering



Electromechanical drive with external power supply

LED (red / green) visible all round signals functioning and errors

- Reliable, precise lubricant discharge independent of temperature and counter pressure
- Quick function control due to visual or electronic signals on the lubrication system and plant error reporting system saves time and relieves maintenance workers



Pressure build-up to 6 bar allows remote mounting up to 5 m

Manual additional discharge via push button on display (purge)

- Mounting up to 5 m outside of dangerous areas or at easy-to-access locations increases workplace safety
- Higher equipment availability since LC can be easily exchanged during running operation
- Lubrication point can be purged to clear blockages

Technical data

Drive – reusable
Electromechanical drive with external power supply: 9–30 V DC, I_{max} 0.5 A
 Discharge period
Time-controlled (TIME)
Impulse-controlled (IMPULSE)
 Lubricant volume
60 cm³, 120 cm³ or 250 cm³
 Operating temperature
-20 °C to +60 °C
 Pressure build-up
6 bar
 Protection class
IP 65
 Standard & special lubricants
Greases up to NLGI 2 / Oils

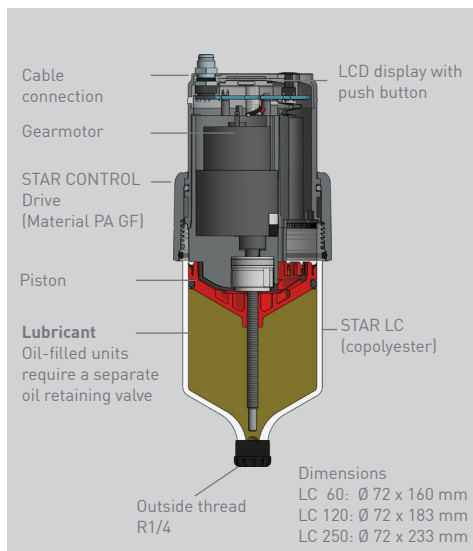

The correct lubricant for a longer service life
perma Lubricants

perma offers a wide range of high-quality lubricants meeting many different requirements. Their consistently high quality has impressed different industries for many years. These lubricants are developed especially for use in perma lubrication systems in cooperation with leading manufacturers. All lubricants are tested and monitored under laboratory conditions and in real applications to ensure optimal function in perma lubrication systems.





Bio-degradable for all applications



ISO 21469 Certified
 Nonfood Compounds
 Program Listed: H1

Oils

Name → Lubricant properties → Labelling as per DIN 51 517-3	Base oil	Operating temperature (°C)	Viscosity at +40 °C [mm ² /s]	Sliding bearings Sliding guides	Open gears Gear racks	Spindles	Chains
perma Food grade oil H1 S070 (CLPH 220) → Broad operating temperature range → Very good ageing & oxidation resistance → Good wear protection  	PAO + ester oil	-30 to +120	220	✓	✓	✓	✓
Bremer & Leguil - CASSIDA CHAIN OIL LT	Synth.	-50 to +140	32	✓	-	-	✓
Klüber - BARRIERTA I S FLUID	PFPE	-25 to +260	425	✓	-	-	-
Klüber - Klüberoil 4 UH1-15	PAO + ester oil	-45 to +110	15	-	-	✓	✓
Klüber - Summit HySyn FG 100	Synth.	-35 to +135	100	-	✓	-	✓
Klüber - UNISILKON TK 002/100	Silicone oil	-50 to +150	75	✓	✓	-	-
OKS - 3570	Synth.	-10 to +250	290	- / ✓	-	-	✓
Setral - FLUID-setral-STG 220 FD	Synth.	-20 to +250	220	✓	✓	✓	✓

HINT

Safety data sheets and technical data sheets for lubricants can be downloaded from www.perma-tec.com/en/lubricants.

Greases

Name → Lubricant properties → Labelling as per DIN 51502	NLGI grade	Thickener	Base oil	Operating temperature (°C)	Base oil viscosity at +40 °C [mm ² /s]	Speed index	Roller bearings	Sliding bearings Sliding guides	Linear guides	Open gears Gear racks	Spindles
perma Food grade grease H1 SF10 (KHC1K-40) → Low-temperature resistance → Good wear protection → Good water resistance 	1	Al com.	PAO	-45 to +120	150	500,000	✓	✓	✓	✓	✓
Bremer & Leguil - Rivolta F.L.G. 3-1	0/00	Al com.	PAO	-40 to +140	100	500000	✓	✓ / -	✓	✓ / -	-
Bremer & Leguil - Rivolta F.L.G. GT-2	2	Ca+Sulfonat	PAO	-45 to +170	85	500000	✓	✓	-	-	-
Castrol - Optileb GR UF 1	1	Al com.	Synth.	-40 to +140	420	0	✓	✓ / -	-	-	-
Fuchs - CASSIDA GREASE EPS 1	1	Al com.	Synth.	-40 to +120	220	400000	✓	✓ / -	-	-	-
Fuchs - CASSIDA GREASE EPS 2	2	Al com.	Synth.	-30 to +120	220	0	✓	✓ / -	-	-	-
Fuchs - CASSIDA GREASE HDS 2	2	Al com.	Synth.	-30 to +120	800	0	✓	✓	-	✓ / -	-
Interflon - Food Grease HD2	2	Ca+Sulfonat	Synth.	-30 to +180	400	250000	-	-	-	-	-
Klüber - BARRIERA L 55/2	2	PTFE	PFPE	-40 to +260	420	300000	✓	✓ / -	-	-	-
Klüber - Klübersynth UH1 14-1600	0	Al com.	Synth.	-45 to +120	0	0	-	-	-	✓ / -	-
Klüber - PARALIQ GA 343	2	Al com.	Min.	-30 to +120	0	300000	✓	✓	-	-	-
Mobil - MOBILGREASE FM 222	2	Al com.		0	220	0	✓	✓	-	-	✓
Petro-Canada - PURITY™ FG1	1	Al com.	PAO	-25 to +160	182	0	✓	✓	-	-	-
Setral - SYN-setral-INT/250 FD	2	PTFE	PFPE	-40 to +260	500	250000	✓	✓	-	-	-



The correct accessories for your mounting solution
perma Accessories

It has never been so easy to integrate automatic lubrication systems in existing production processes. Our expertise is based on many years of experience and global know-how. perma Customers obtain all necessary components from a single supplier and also benefit from service and support to implement customised lubrication solutions.

Determination of mounting type

Example: Direct mounting

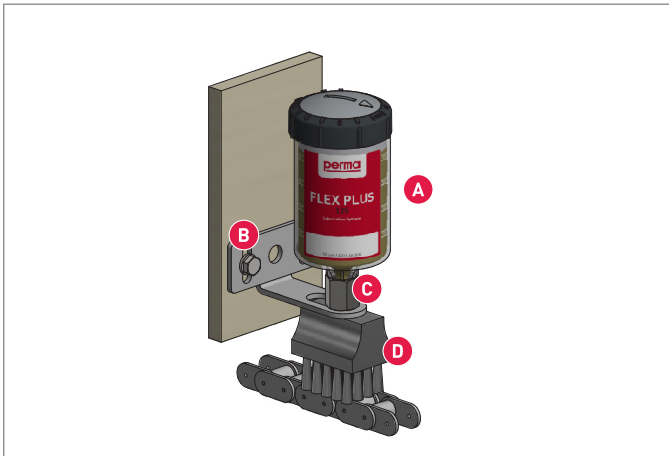

A	1x perma FLEX PLUS 125
B	1x Bracket
C	1x Insert for bracket G1/4 male x G1/4 female
D	1x Oil brush up to +350 °C 40 x 30 mm G1/4 female thread on top

Benefits: Direct mounting

- ✓ **Little installation work required**
- ✓ Automatic lubrication systems can be **screwed into position by hand**
- ✓ **Immediate supply** of lubrication points with **fresh lubricant**

Example: Remote mounting

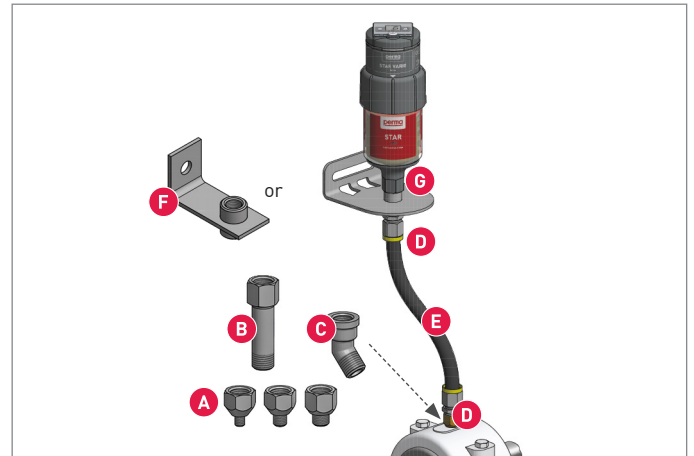

A	1x Reducer G1/8 male x G1/4 female 1x Reducer M6 male x G1/4 female 1x Reducer M8x1 male x G1/4 female 1x Reducer M10x1 male x G1/4 female
B	1x Extension 45 mm G1/4 male x G1/4 female
C	1x Angle 45° R1/4 male x Rp1/4 female
D	2x Hose connector G1/4 male for hose iØ 9.5 mm - push-lock
E	1x Heavy Duty hose up to +100 °C oØ 16 mm x iØ 9.5 mm (with NBR lining and fabric insert)
F	1x Mounting bracket 1-point G1/4 female
G	1x Mounting bracket STAR Standard Duty 1-point G1/4 female

Benefits: Remote mounting

- ✓ Relocate lubrication point to a **safe area**
- ✓ **Vibrations** at the lubrication point can be **disregarded**
- ✓ Automatic lubrication systems can be installed **behind panels** and **outside restricted areas**

NOTE

Use the same lubricant as in the lubrication system for pre-filling grease lines.

Tubes

Name Material → Properties	Art. No. (meter goods)	iØ/oØ [mm]	Operating temperature range [°C]	Minimum bending radius [mm]	Max. operating pressure [bar]	Initial filling amount per m [cm ³]	Silicone-free / halogen-free	Max. grease line* [m]	
								FLEX / FLEX PLUS	STAR VARIO / STAR CONTROL
VA-Flex tube stainless steel / PTFE → High resistance to fractures and impacts → High temperature resistance	113864 (500 mm) 101549 (1000 mm) 101550 (1500 mm)	8/11	-150 to +260	70	220	55	✓	2	5
Tube PA → UV-resistant → Resistant to water → Translucent	101393	6/8	-40 to +80	40	19	33	✓	2	3
Tube PTFE → Good temperature resistance → Noncombustible (flammability class V-0) → Suitable for food and beverage → Translucent	101394	6/8	-70 to +260	50	9	33	-	2	3

* The maximum length of the grease line depends on the lubrication system, lubricant and operating temperature. Information applies at +20 °C using perma Multipurpose grease SF01 or perma High performance oil S014.



Accessories

Accessories	Pic.	Material	Art. No.
Tube connector G1/4 female for tube oØ 8 mm	1	Stainless steel	104866
Tube connector G1/4 male for tube oØ 8 mm	2		104867
Cutting ring coupling R1/4 male for oØ 8 mm straight	3		104868
Cutting ring coupling R1/8 male for oØ 8 mm 90° adjustable	4		104869
Cutting ring coupling R1/8 male for oØ 8 mm straight	5		104870
Cutting ring coupling straight - connector for oØ 8 mm	6		104871
Angle 90° R1/4 male x Rp1/4 female	7		104874
Reducer G1/8 male x G1/4 female	8		104875
Reducer M6 male x G1/4 female	9		104876
Reducer M8x1 male x G1/4 female	10		104877
Reducer M8 male x G1/4 female	11		104878
Reducer M10x1 male x G1/4 female	12		104879
Purge connection with manual valve R1/4 male x G1/4 female	13		113973
Oil retaining valve G1/4 male x G1/4 female up to +60 °C - stainless steel with plastic valve	14		104889

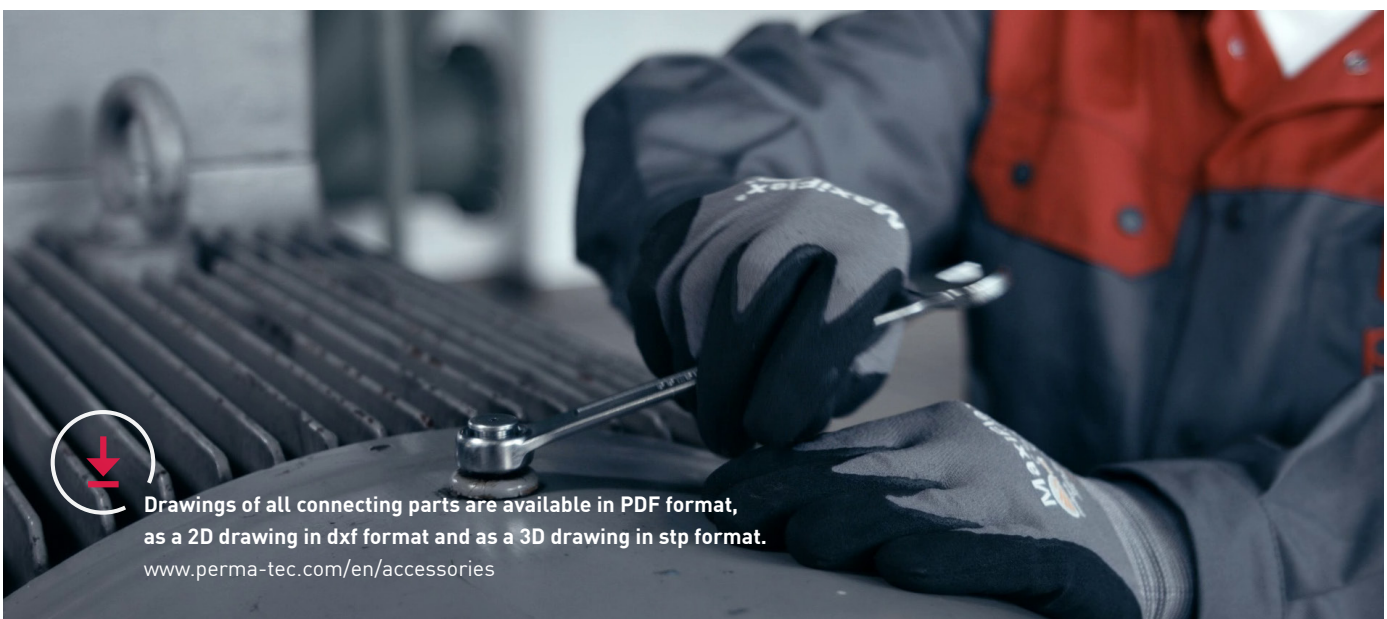
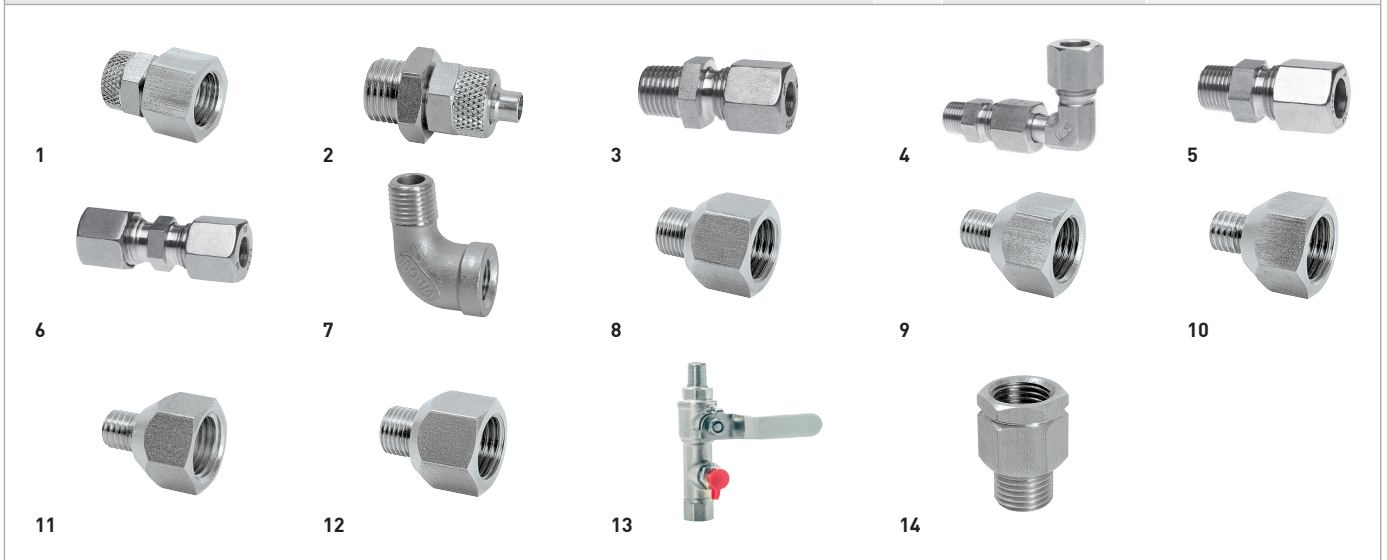

Accessories

Accessories	Pic.	Material	Art. No.
Reducer G1/8 male x G1/4 female	1	Stainless steel	104875
Reducer M6 male x G1/4 female	2		104876
Reducer M8x1 male x G1/4 female	3		104877
Reducer M10x1 male x G1/4 female	4		104879
Tube connector G1/8 male for tube oØ 8 mm straight	5	Brass, nickel-plated	101570
Tube connector G1/4 male for tube oØ 8 mm 90° - rotary type	6		101497
Tube connector M6 male for tube oØ 8 mm straight	7		111954
Tube connector M8x1 male for tube oØ 8 mm straight	8		111955
Tube connector G1/4 male for tube oØ 8 mm straight	9		101496
Tube connector M10x1 male for tube oØ 8 mm straight	10		111956
Tube connector M6 male for tube oØ 8 mm 90° - rotary type	11		111957
Tube connector M10x1 male for tube oØ 8 mm 90° - rotary type	12		111959
Tube connector M8x1 male for tube oØ 8 mm 90° - rotary type	13		111958



1



2



3



4



5



6



7



8



9



10



11



12



13

Special Accessories

Special Accessories	Pic.	Material	Art. No.
Oil brush up to +350 °C 40 x 30 mm G1/4 female thread on top	1	Stainless steel	101405
Oil brush up to +350 °C 60 x 30 mm G1/4 female thread on top	2		101406
Oil brush up to +350 °C 100 x 30 mm G1/4 female thread on top	3		101407
Mounting bracket left for oil brush for large chains	4		101533
Mounting bracket right for oil brush for large chains	5		101534
Oil brush for large chains up to +350 °C with tapped bore M6	6	Alu / Stainless steel	101540
Oil brush for large chains up to +350 °C with through hole	7		101541
Lubricating pinion for chains	8		On request



1



2



3



4



5



6



7









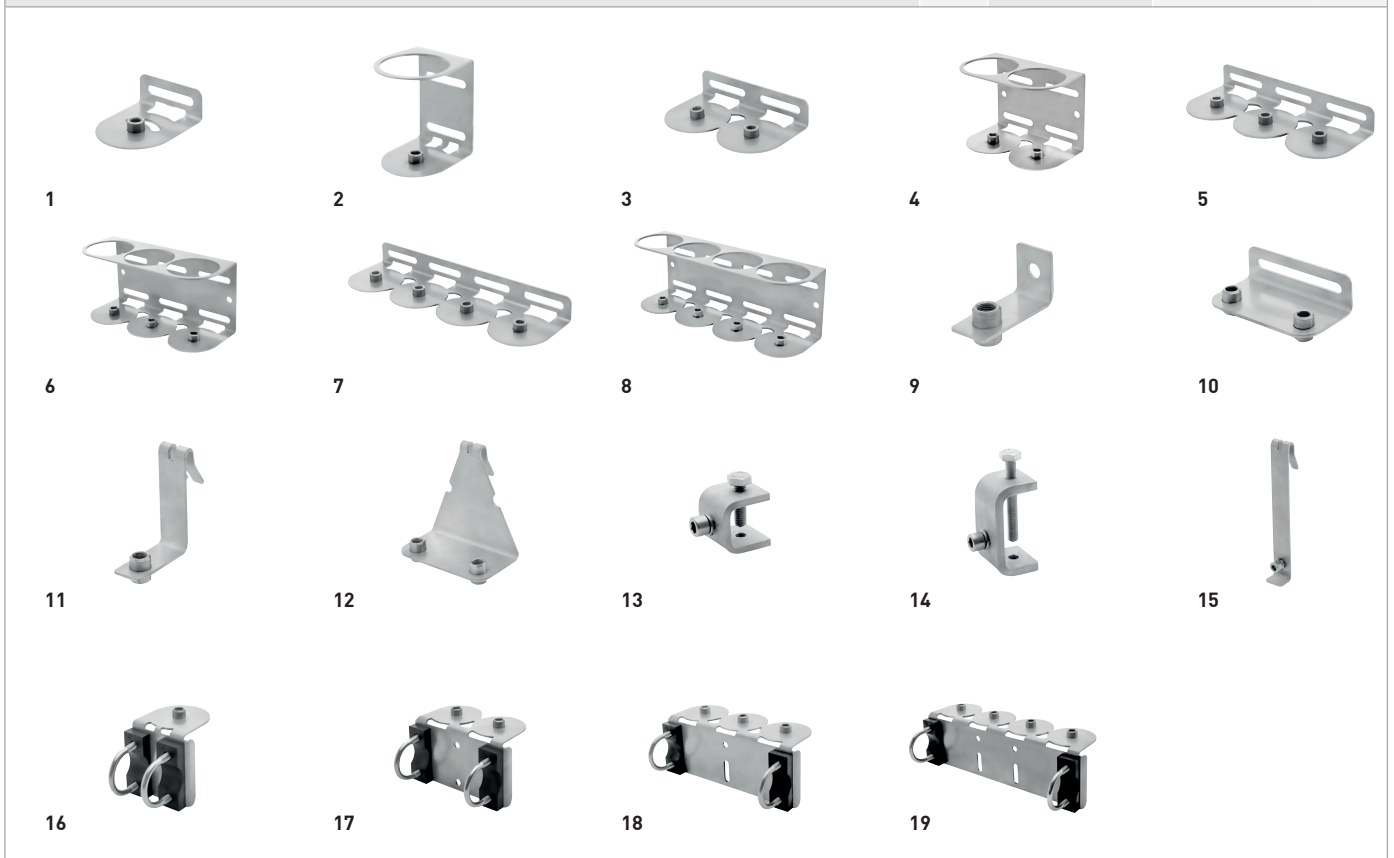

8

Brackets

Brackets	Pic.	Material	Art. No.
Mounting bracket STAR Standard Duty 1-point G1/4 female	1	Stainless steel	109663
Mounting bracket STAR Heavy Duty C-section 1-point G1/4 female	2		109664
Mounting bracket STAR Standard Duty 2-point G1/4 female	3		109667
Mounting bracket STAR Heavy Duty C-section 2-point G1/4 female	4		108648
Mounting bracket STAR Standard Duty 3-point G1/4 female	5		109670
Mounting bracket STAR Heavy Duty C-section 3-point G1/4 female	6		109671
Mounting bracket STAR Standard Duty 4-point G1/4 female	7		109673
Mounting bracket STAR Heavy Duty C-section 4-point G1/4 female	8		109674
Mounting bracket CLASSIC, FUTURA, FLEX, NOVA 1-point G1/4 female	9		109685
Mounting bracket CLASSIC, FUTURA, FLEX, NOVA 2-point G1/4 female	10		109686
Mounting bracket CLASSIC, FUTURA, FLEX, NOVA cage hanger 1-point G1/4 female	11		109689
Mounting bracket CLASSIC, FUTURA, FLEX, NOVA cage hanger 2-point G1/4 female	12		109690
Beam clamp 30 mm	13		109957
Beam clamp 65 mm	14		109958
Cage hanger arm	15		109959
Mounting bracket STAR rail mount 1-point G1/4 female incl. 2 U-Bolts	16		110014
Mounting bracket STAR rail mount 2-point G1/4 female incl. 2 U-Bolts	17		110015
Mounting bracket STAR rail mount 3-point G1/4 female incl. 2 U-Bolts	18		110016
Mounting bracket STAR rail mount 4-point G1/4 female incl. 2 U-Bolts	19		110017



Overview of perma lubrication systems

Product	Lubricants	Discharge periods	Controlled	Max. lubrication points	Max. pressure [bar]	Operating temperature [°C]	Volume [cm ³]	Drive / Power supply	Activation / Setting	Certifications
Single-point lubrication systems, electrochemical										
	FLEX	Greases up to NLGI 2 / Oils	Time	1	5	-20 to +60	60 125	Electrochemical / Integrated battery	Rotary switch	   
	FLEX PLUS									
Single-point lubrication systems, electromechanical										
	STAR VARIO	Greases up to NLGI 2 / Oils	Time	1	6	-20 to +60	60 120 250 500	Gearmotor / Battery	Push button with display	
	STAR CONTROL		Individual							

* Depending on operating temperature and counter pressure

All perma products conform to CE.



Applications



Flange bearing lubrication on a filling machine conveyor



Pillow block lubrication on a drive pulley



Chain lubrication of a conveyor line

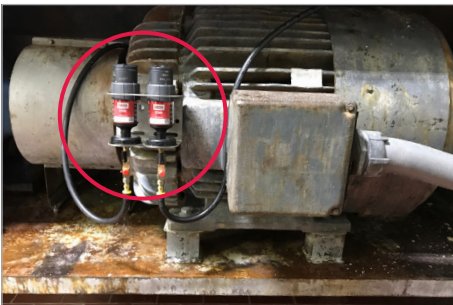

Remote bearing lubrication on an electric motor



Remote pillow block lubrication on a belt weigher



Oven chain lubrication on a baking line



Drive pulley bearing lubrication on an oven

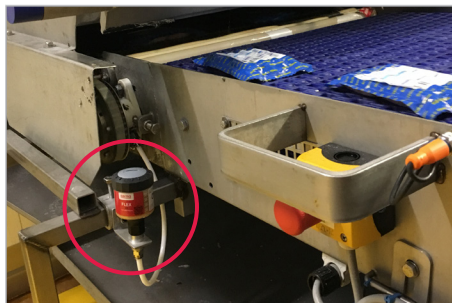

Remote flange bearing lubrication on a conveyor



Remote pillow block lubrication on a guide pulley

Individual solutions

perma Product portfolio



Solutions for all types of applications

perma Lubricants

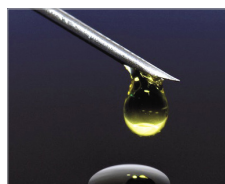

Large selection of high quality **NSF** lubricants to meet the requirements of your equipment

perma Accessories



Extensive range of accessories and connecting parts for your equipment

perma SERVICE



Project planning, installation and maintenance

perma SOFTWARE



Calculation of lubricant amount: • **perma SELECT**
Maintenance Lubrication Program: • **perma MLP**