

6.1.7 A – Standard connection

A - Standard connections are connecting elements for the combination from Linear Axis of the series AXC and AXDL with axis with toothed belt - Ω - drive of the series AXC and AXDL (Figure 6.17).

The A – standard connections contain all the essential connecting elements including screws.

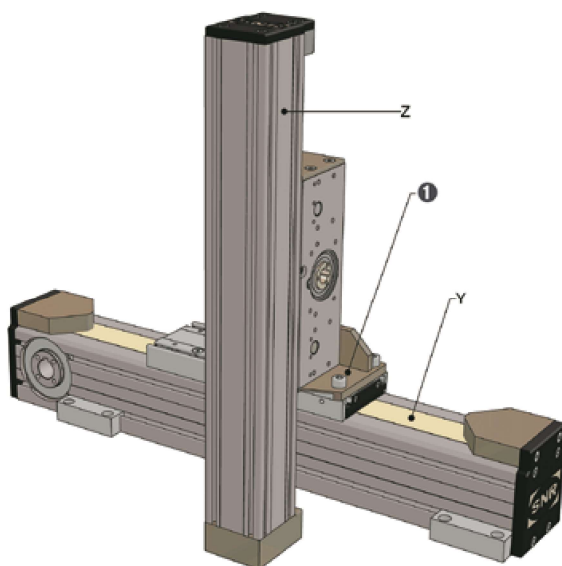

- 1 Optional fixation of the position adapted for the assembling as a 3 – axis – system with direct connection to the X – axis

Figure 6.17 — A – Standard connection AXC / AXDL

The type codes and dimensions including ID number of the A - standard connections are shown in Figure 6.18 and Table 6.10.

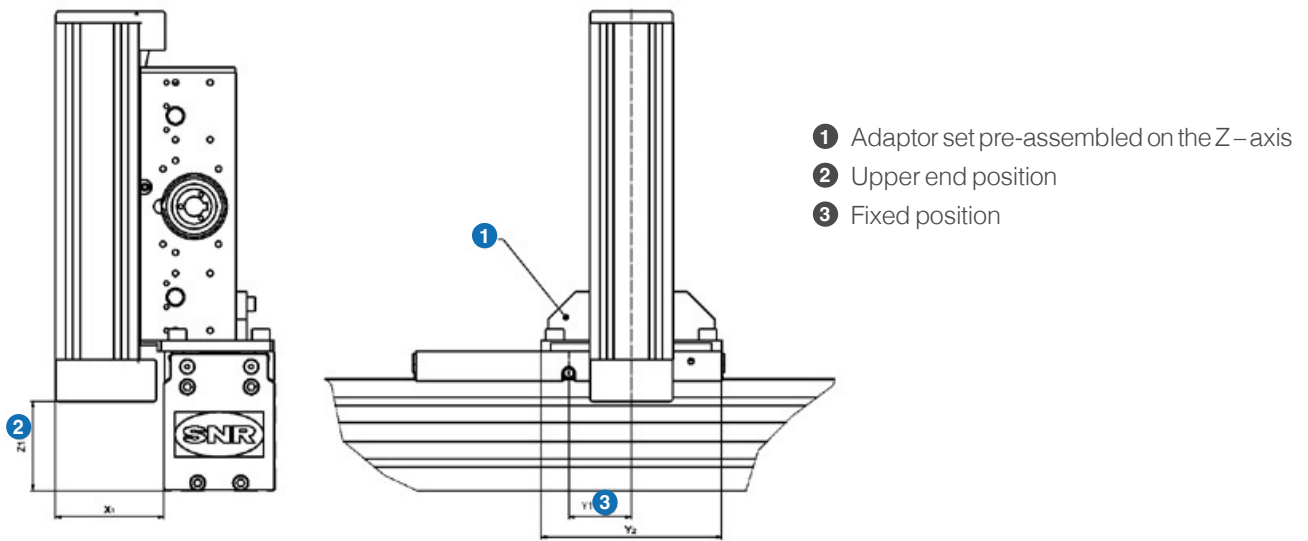

Figure 6.18 — A – Standard connection AXC / AXDL

Table 6.10 — A – Standard connection AXC / AXDL

Y - Axis	Z - Axis	Code number ¹	X1 [mm]	Y1 [mm]	Y2 [mm]	Z1 [mm]
AXC60	AXC40A	A	61	0	120	60,0
AXC80	AXC60A	B	78	45	130	64,0
AXC80A				20		114,0
AXC100_B AXC100_C AXC100_L	AXC80A	C	102	0	150	62,5
AXC100_D			100			
AXC120			92	59	150	87,5
AXC120A				0 / 55		157,5
AXDL110	AXC40A	D	61	0	132	43,0
	AXC60A	E	90	0 / 18	130	29,0
AXDL160	AXC60A	F	75	0	150	51
	AXC80A	G	110	0	150	22,5
AXDL240	AXC120A	H	140	0	200	20,0

¹ A-Standard connection is installed at the factory, insert the code number in the type code at position 10 (additional option)