

## HBD-50 to HBD-85

### Regulation at the highest level

#### Adjustable, Without Free Travel

**Compression and extension force 100 N to 50,000 N**

**Stroke 50 mm to 700 mm**

Motion control in both directions: The HBD model of hydraulic dampers can be adjusted independently in both the push and pull direction. These maintenance-free, ready-to-install and closed systems leave no prayers unanswered as far as the setting of retraction and extension speeds are concerned. In addition each damper works without any free travel therefore the flow of oil can be regulated exactly via the two precision metering orifices.

Adjustment can be made once installed and even when moving through stroke. The coated body and hard-chromed piston rods stand for quality and long service life. The variety of mounting accessories makes assembly easy and the high-end hydraulic dampers universally usable.

HBD hydraulic dampers are used in the automotive, in industry, mechanical engineering and medical technology.

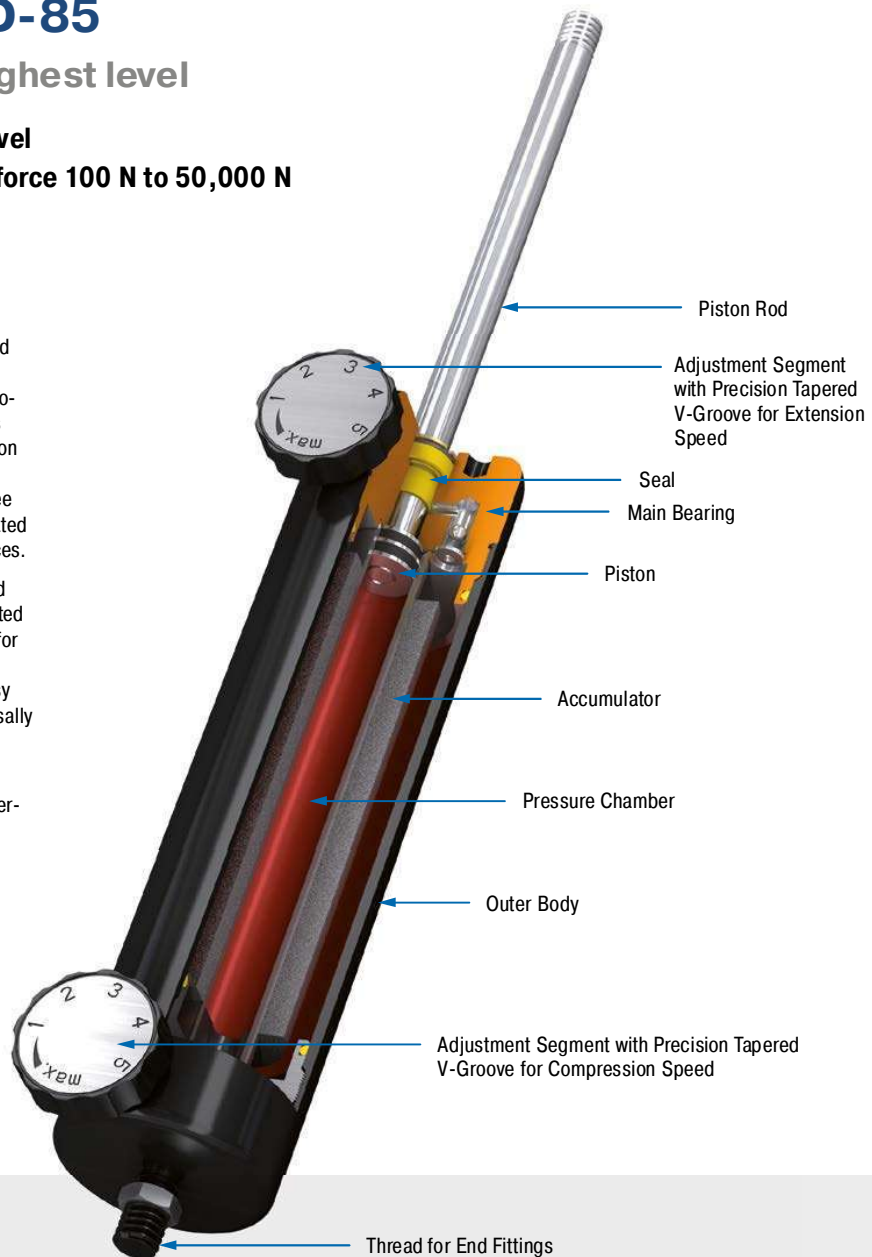

#### Technical Data

**Compression and extension force:** 100 N to 50,000 N

**Outer body diameter:** Ø 50 mm to Ø 85 mm

**Piston rod diameter:** Ø 10 mm to Ø 20 mm

**Lifetime:** Approx. 10,000 m

**Operating temperature range:** 0 °C to 65 °C

**Adjustment:** Steplessly adjustable

**Positive stop:** External positive stops 1 mm to 3 mm before the end of stroke provided by the customer.

**Damping medium:** hydraulic oil

**Material:** Outer body: coated steel; Piston rod: hard chrome plated steel; End fittings: zinc plated steel

**Mounting:** in any position

**Application field:** sports equipment, rehabilitation technology, conveyor technology

**Note:** Increased break-away force if unit has not moved for some time. One locknut included.

**End fittings:** They are interchangeable and if necessary must be positively secured by the customer to prevent unscrewing.

**On request:** Special oils and other special options. Alternative accessories available on request.

Adjustable, Without Free Travel, Compression and extension force 100 N to 6,000 N

**End Fitting**

**Standard Dimensions**

**End Fitting**

**Performance and Dimensions**

TYPES	Stroke mm	L extended mm	1 Compression force max. N
HBD-50-50	50	192	6.000
HBD-50-100	100	292	6.000
HBD-50-150	150	392	4.400
HBD-50-200	200	492	2.800
HBD-50-250	250	592	2.000
HBD-50-300	300	692	1.400

<sup>1</sup> Max. extension force for all stroke lengths 6,000 N.

**Ordering Example**  
**HBD-50-150-EE-P**  
 Type (Hydraulic Damper) \_\_\_\_\_  
 Body Ø (50 mm) \_\_\_\_\_  
 Stroke (150 mm) \_\_\_\_\_  
 Piston Rod End Fitting E10 \_\_\_\_\_  
 Body End Fitting E10 \_\_\_\_\_  
 Damping Direction (P = Damping in both directions) \_\_\_\_\_

**Model Type Prefix**  
 P: Damping in both directions (standard model)  
 M: Damping on out stroke only (adjustment knob at "rear end" free flow)  
 N: Damping on in stroke only (adjustment knob at "piston rod end" free flow)

**Mounting accessories see from page 200.**

**End Fitting Options:**  
 Stud Thread **B10**  
 Eye **A10** max. force 10,000 N  
 Angle Ball Joint **C10** max. force 1,800 N  
 Clevis Fork **D10** max. force 10,000 N  
 Swivel Eye **E10** max. force 10,000 N

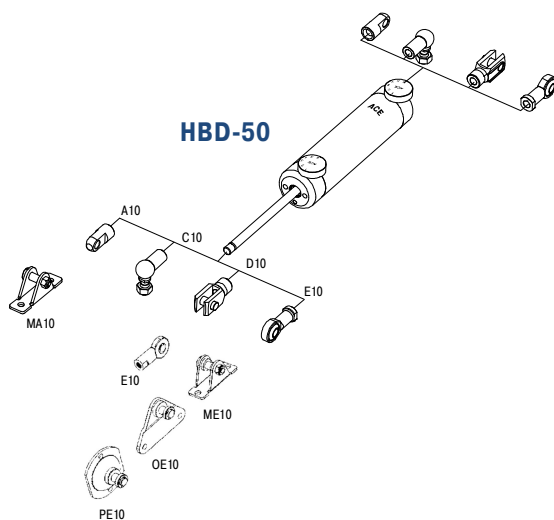

**Technical Data**

- Compression and extension force:** 100 N to 6,000 N
- Operating temperature range:** 0 °C to 65 °C
- Adjustment:** Steplessly adjustable
- Positive stop:** External positive stops 1 mm to 1.5 mm before the end of stroke provided by the customer.
- Material:** Outer body: Coated steel; Piston rod: Hard chrome plated steel; End fittings: Zinc plated steel
- Mounting:** In any position
- Note:** Increased break-away force if unit has not moved for some time. One locknut included.
- End fittings:** They are interchangeable and if necessary must be positively secured by the customer to prevent unscrewing.

Issue 07.2017 – Specifications subject to change

## Hydraulic Dampers HBD-70



Adjustable, Without Free Travel, Compression and extension force 150 N to 10,000 N

### End Fitting

### Standard Dimensions

### End Fitting

#### B14

#### A14

#### Stud Thread B14

max. force 10,000 N

#### C14

#### D14

#### Angle Ball Joint C14

max. force 3,200 N

#### E14

#### E14

#### Clevis Fork D14

max. force 10,000 N

#### E14

#### E14

#### Swivel Eye E14

max. force 10,000 N

TYPES	Stroke mm	L extended mm	<sup>1</sup> Compression force max. N
HBD-70-100	100	306	10,000
HBD-70-150	150	406	10,000
HBD-70-200	200	506	10,000
HBD-70-300	300	706	10,000
HBD-70-400	400	906	8,000
HBD-70-500	500	1,106	6,000

<sup>1</sup> Max. extension force for all stroke lengths 10,000 N.

**Ordering Example**

**HBD-70-300-EE-P**

Type (Hydraulic Damper) \_\_\_\_\_

Body Ø (70 mm) \_\_\_\_\_

Stroke (300 mm) \_\_\_\_\_

Piston Rod End Fitting E14 \_\_\_\_\_

Body End Fitting E14 \_\_\_\_\_

Damping Direction (P = Damping in both directions) \_\_\_\_\_

**Model Type Prefix**

P: Damping in both directions (standard model)

M: Damping on out stroke only (adjustment knob at "rear end" free flow)

N: Damping on in stroke only (adjustment knob at "piston rod end" free flow)

Mounting accessories see from page 200.

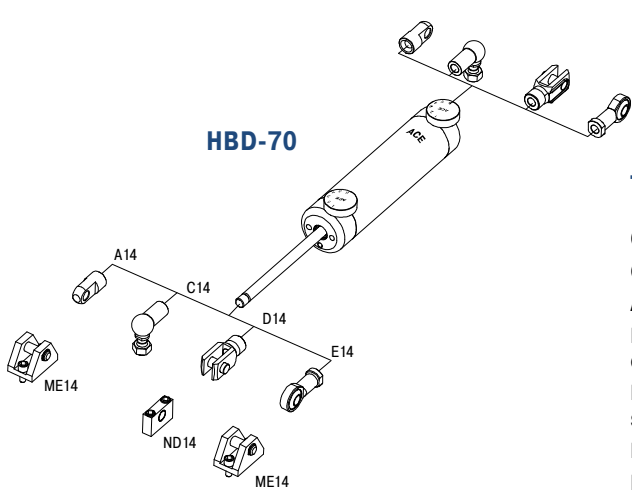

### Technical Data

- Compression and extension force:** 150 N to 10,000 N
- Operating temperature range:** 0 °C to 65 °C
- Adjustment:** Steplessly adjustable
- Positive stop:** External positive stops 1 mm to 1.5 mm before the end of stroke provided by the customer.
- Material:** Outer body: Coated steel; Piston rod: Hard chrome plated steel; End fittings: Zinc plated steel
- Mounting:** In any position
- Note:** Increased break-away force if unit has not moved for some time. One locknut included.
- End fittings:** They are interchangeable and if necessary must be positively secured by the customer to prevent unscrewing.

Adjustable, Without Free Travel, Compression and extension force 150 N to 50,000 N

**End Fitting**

**Standard Dimensions**

**End Fitting**

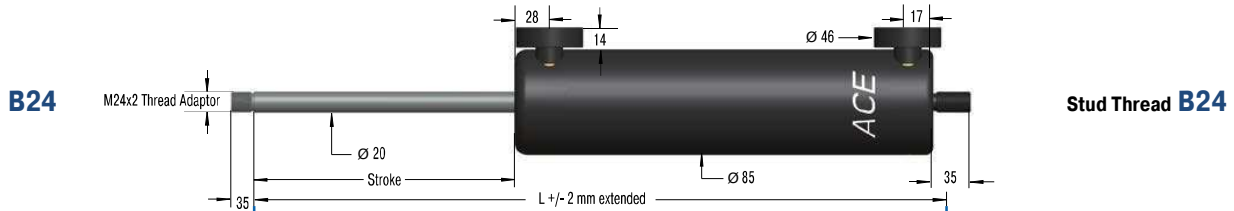

**B24**

**Stud Thread B24**

**D24**

**Clevis Fork D24**  
max. force 50,000 N

**E24**

**Swivel Eye E24**  
max. force 50,000 N

**Performance and Dimensions**

TYPES	Stroke mm	L extended mm	<sup>1</sup> Compression force max. N
HBD-85-100	100	313	50,000
HBD-85-150	150	413	30,000
HBD-85-200	200	513	20,000
HBD-85-300	300	713	10,000
HBD-85-400	400	913	6,500
HBD-85-500	500	1,113	4,000
HBD-85-600	600	1,313	3,000
HBD-85-700	700	1,513	2,000

<sup>1</sup> Max. extension force for all stroke lengths 50,000 N.

**Ordering Example**

**HBD-85-300-EE-P**

- Type (Hydraulic Damper) \_\_\_\_\_
- Body Ø (85 mm) \_\_\_\_\_
- Stroke (300 mm) \_\_\_\_\_
- Piston Rod End Fitting E24 \_\_\_\_\_
- Body End Fitting E24 \_\_\_\_\_
- Damping Direction (P = Damping in both directions) \_\_\_\_\_

**Model Type Prefix**

- P: Damping in both directions (standard model)
- M: Damping on out stroke only (adjustment knob at "rear end" free flow)
- N: Damping on in stroke only (adjustment knob at "piston rod end" free flow)

**Mounting accessories see from page 200.**

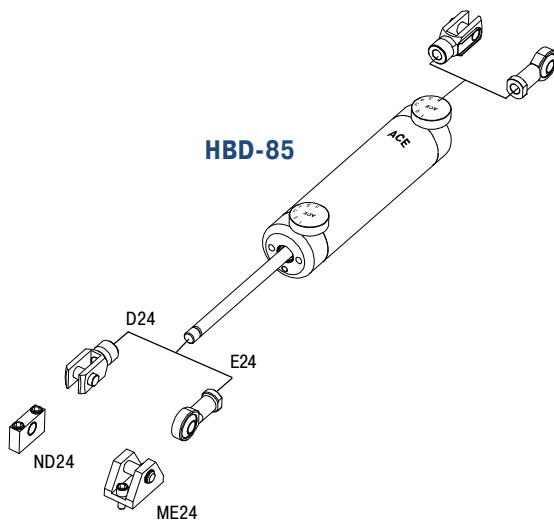

**Technical Data**

- Compression and extension force:** 150 N to 50,000 N
- Operating temperature range:** 0 °C to 65 °C
- Adjustment:** Steplessly adjustable
- Positive stop:** External positive stops 2 mm to 3 mm before the end of stroke provided by the customer.
- Material:** Outer body: Coated steel; Piston rod: Hard chrome plated steel; End fittings: Zinc plated steel
- Mounting:** In any position
- Note:** Increased break-away force if unit has not moved for some time. Thread adaptor for piston rod from M16 to M24 included.
- End fittings:** They are interchangeable and if necessary must be positively secured by the customer to prevent unscrewing.

Issue 07.2017 – Specifications subject to change